

SAMSON

SAMSON SED

CATALOG

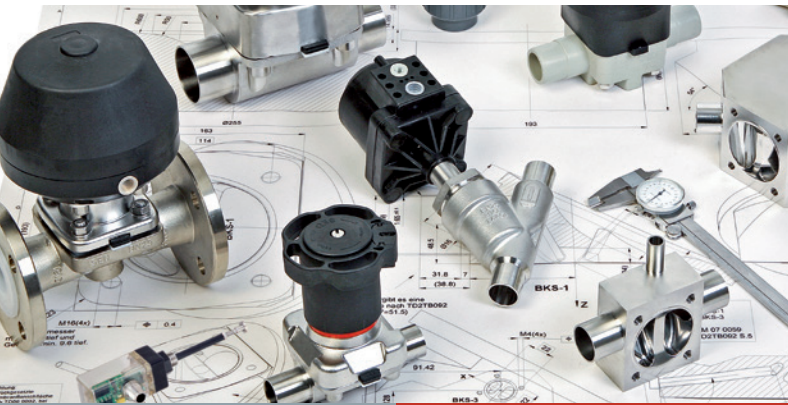

Valves for aseptic Applications

Aseptic Applications



Pharmaceutical Project



Filtration Skid

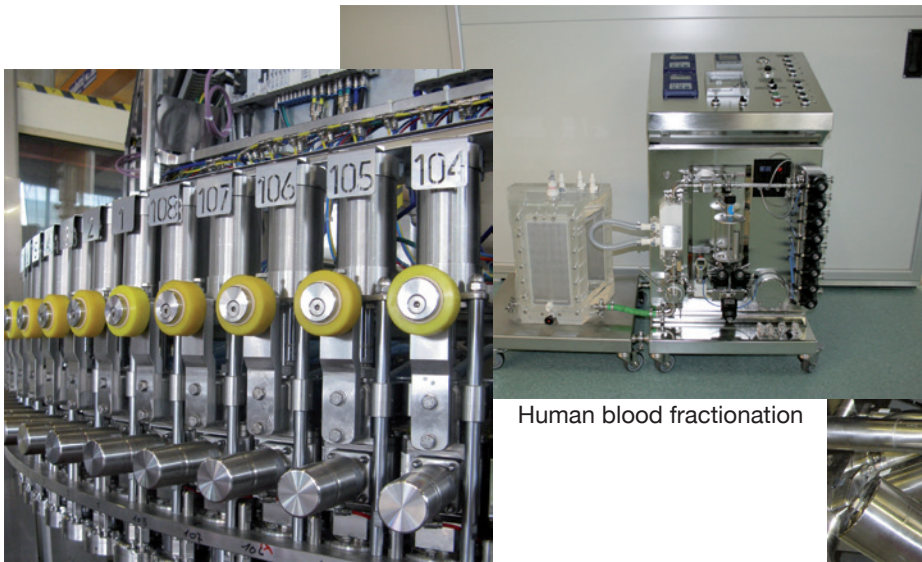

Filling

Human blood fractionation



Mixing



Bioreactor Skid



Biopharm Project

Table of Contents

1	Introduction	Page
	A Brief Overview	4
	The Company	5
	What does Quality mean at SED?	6
	General Information	
	Testing	7
	Qualification, Certification and Documentation	8
	Flow Rate and Valve Sizing	9
	Surface Finish	10, 11
2	Media Contacted Components	
	Diaphragms	14 - 19
	Valve Bodies (fold out page)	20
	Butt Weld Tube Ends (fold out page)	21
	Aseptic Connections	
	Clamps	22
	Aseptic Flanges and Aseptic Threads	23
3	Aseptic Diaphragm Valves	
	Overview Diaphragm Aseptic Valves	26, 27
	Why Aseptic Diaphragm Valve?	28
	Self Draining - Two-Way Valve	29
	Innovative Design	30 - 33
	Aseptic Diaphragm Valves	
	Aseptic Diaphragm Valve Manual	34 - 45
	Aseptic Diaphragm Valve Pneumatically Operated	46 - 61
	Ordering Key and Ordering Example	62, 63
4	Aseptic Diaphragm Valve Configurations	
	D-Rule	66
	Welded Valve Configurations	67 - 69
	Multiport Valves	
	Why Multiport Valves?	70
	Main line open, Loop Valves (e.g. T-Valve)	71 - 75
	All lines and valve ports able to close	76 - 81
	The way of customized multiport valve designs	82
	Specification Multiport Valves	83
	Tank Valves	84 - 87
	Process Solutions	
	Sterile Sampling Unit	88
	Purified Steam Sampling Unit	89
5	Angle Seat Valves	
	Description and Features	92
	Applications	93
	Ordering Key and Ordering Example	94, 95
	Technical Data	96
	2/2-Way Angle Seat Valves	97 - 103
	Valve Body Threaded Socket and Butt Weld End	104
	Valve Body Clamp Socket and Flange	105
6	System Components and Process Automation	
	Overview	108
	Manual Adjustment - Optical Indication	109
	Electrical Switch Boxes - Pilot Control	110
	Detailed Information	
	3/2 Way Plastic Pilot Valve Type 600 / 605	111
	3/2 Way Plastic Pilot Valve Type 602 / 603	112
	Control Head Switch 024.63. - 024.89.	113
	Contact-Free Limit Switch 024.50	114, 115
	Process Automation, Electropneumatic Positioners	116 - 118
	Overview Product Range	119
	Glossary	120, 121

A Brief Overview



The office building is connected to the production building for direct communication with manufacturing.

SED was founded in 1984 and is engaged in the development, manufacture and distribution of sophisticated valve technology and flow meters.

The aseptic diaphragm valve and all the corresponding components is the main focus of SED.

With more than 20 years of experience, continuous research and development guarantees that our products are of the highest quality and reliability in all process applications.

The SED versatile and comprehensive product offering provides many advantages to our customers. Our modular design allows for the reduction of stock inventory, prompt deliveries and our customized designs offer solutions for the most demanding process applications.

A market-oriented and complete range of system components for the monitoring and regulation of valves is readily available and is continuously improved and expanded to meet the market requirements.

Our employees training and experience over the years have developed an attitude which is characterized by flexibility and meeting our customer's needs.

We continue to invest in our state-of-the-art production facilities which allows for the competitive manufacture of cost effective solutions for the special and demanding needs of our customer's high quality standards.

Our Advantages:

- Highly qualified employees with many years of experience in the development and manufacturing of valve components and systems.
- Valve technologies with an innovative design and creative customized solutions.
- Modular and compact assembly of our products.
- High vertical range of manufacturing allows for a high degree of flexibility.
- Comprehensive selection of accessories for valve monitoring and regulation.
- International sales network and a dedicated internal sales staff.



Production building

The Company

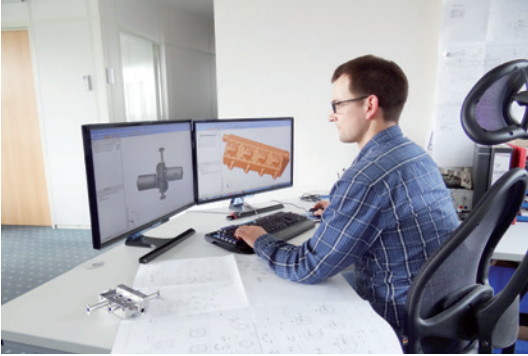

CAD- CAM working station

The company has installed the most modern machinery and individual production facilities which are fully adapted to current market requirements.

Specifically:

- The 3D-CAD-CAM network connects all the CAD workstations with the 3 and 5 axis CNC machining facilities, bringing our products from conception to development.
- Injection molding manufacturing, special injection molding machines, and tools adapted to high performance plastics and specific processes.
- Assembly in clean room facilities with ultrasonic clean washing including other automated assembly capabilities.
- Work stations which are ergonomically designed for the health and safety of our employees.
- Programmable welding machine and polishing work stations for aseptic diaphragm valves in order to guarantee the greatest flexibility and quality.



Ultrasonic cleaning of valve bodies



Valve cluster assembled with patent Steripur and KMA actuation



CNC machining center

What Does Quality Mean at SED?

The complete satisfaction of our customer is our ultimate benchmark for quality. Only then, may a successful and sustained existence in the market be guaranteed.

The prerequisite for quality is not only a functional product but also that the quality concept is applied comprehensively to all areas of our business. This includes research and development, production, suppliers, services and our sales team.

The Fundamental Areas of Our Quality Policy:

Products and Services:

An accelerated implementation of customized solutions is achieved with personal conversations and direct customer input.

This is supported by the specialization of SED through development and production areas with efficient experience and extensive training requirements.



Process system application with standard and multiport compact customized valve solutions

Suppliers:

The quality of our products is directly dependent on the performance of our suppliers.

Through a supplier qualification process, continuous assessments are performed, documented and form the basis of a close customer-supplier-relationship.



Spectrometer and RFA material analysis

Work Sequences:

For each individual step of the manufacturing process the motto "My colleague is my customer" applies. This means that everybody has to handle their production responsibility in a way that the internal customer is satisfied and that their best work is possible.

Customers:

Our customer is our employer and should see their visions and wishes realized. This means that our goal is to work together with our customers to develop solutions and implement these solutions with cost effective results.

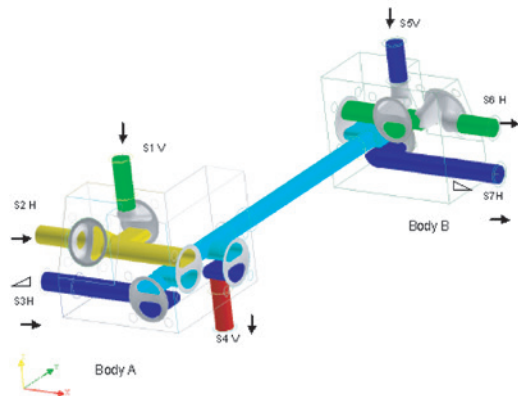

3D modeling and flow direction of a multivalve cluster

Employees:

The greatest asset of our company is our employees. Embracing quality is not the result of an individual but the outcome of successful teamwork. The ability to develop new ideas, to take on responsibility and to show initiative and creativity brings us continuous development and improvement. Each level of the company believes in our quality and growth philosophy and this is reinforced with continued education.

Complete Valve Assembly Inspection

- 100% according to checklist

Diaphragm Valve Seal Test

- Test according to DIN EN 12266-1
- 100% valve assemblies seal tested

Internal Surface Finish

- 100% visual inspection
- Profilometer inspection as per specification

Weld Seam Testing

- 100% visual inspection
- 100% borescope inspection of all weld seams not directly visible with the eye or as per specification
- 100% pressure testing

Non-Destructive Testing for media contacted body material (on demand or internal specification requirements)

- Of material composition
 - Spectrometer
 - Delta ferrite
- Of material structure
 - Visually
 - Porosity testing by liquid penetration
 - X-ray
- Dimensional control
 - Standard and specific measuring device
 - Coordinate measuring machine (CMM)

Verification Certificates according to Specification DIN EN 10204

- 3.1 Analysis of the material traceability by heat number (U.S. Certified Mill Test Report-MTR). This also applies to all ASME BPE compliant material used in fabrications.
- 2.2 Confirmation of conformance by documentation of results
- 2.1 Confirmation of conformance with the specification



Borescope inspection of the interior surface and weld seams of valves for aseptic applications



Delta Ferrite measurement of stainless steel valve bodies



Zeiss Coordinate measuring machine (CMM)

Checklist

SED Prüfanweisung für Edelstahl-Verstellkörper Überprüfung vor dem Versand # SEDGRAD/FALHAF/PA/0001.pdf		PA 030001 Ausgabe: 20.04.2006 Seite: 1 von 1	
Auftragsnummer AB: <u>4604334</u> P/Nr.: <u>5-238-10-438-45-338</u> P/Nr.: <u>AK</u> Datum: <u>02.05.06</u>			
Checkliste vor dem Versand:			
1	Stützen auf Beschädigung und Scharfkantigkeit prüfen (DIN ISO 13715 v. 9.05)	Freigebe P/Nr./PC	Freigebe Versand
2	Übergewichte nach ISO 9001 kontrollieren	AK	RR
3	Außenbeschuss, Wundlöcher		
4	Schweißnähte nach XRT kontrollieren		
5	3.1 Normen vorlesen und abgelesen		
6	Verbindungsflansche und wenn gefügt		
7	Elektronen prüfen (Messung nach dem Heat-Nr. nicht angebracht)		
8	Heat-Nr. Markieren auf Test mit Heat-Nr. aufbringen		
9	Prüfen ob Heat-Nr. Markieren als 3.18 Zeichnung ist (als Papierabzug bzw. PC-Beschreibung)		
10	Schweißnähte		
11	Scharfkanten prüfen		
12	Schweißnaht entfernen, Abgerundung/Flacke prüfen		
13	3.18 Zeichnung abgelesen		
14	Prüfen ob Heat-Nr. Markieren auf 3.18 Zeichnung ist (als Papierabzug bzw. PC-Beschreibung)		
15	Verstellkörper abgelesen und auf 3.18		

SEAT INDUSTRIALE
 SEAT S.p.A.
 Via S. Maria 10, 37060 S. Maria (Verona) - Italy
 Tel. +39 0445 461111 Fax +39 0445 461112
 E-mail: info@se.it

Test Certificate 2001/000166
 Date 17/01/2004
 Page

SED FLOW CONTROL GmbH
 RAIFEISENSTR. 10A-D
 74906 BAD RAPPENAU

Customer Order	1570216001	Delivery Note	1570216001	Invoice	030001	Delivered Q. ty	20.00
Code Article	1570216001	Flow Description	1570216001	Flow Description	1570216001		
Flow Code/Week Nr.	1570216001	Flow Description	1570216001	Flow Description	1570216001		
Flow Code/Week Nr.	1570216001	Flow Description	1570216001	Flow Description	1570216001		
Heat Number	1570216001	Heat Number	1570216001	Heat Number	1570216001		

3.1 Analysis of the material

Qualification, Certification and Documentation

Certified Process Qualification

- Quality Management System ISO 9001
- Environment Management System ISO 14001
- Energy Management System ISO 50001
- Manufacturing Process AD2000 Merkblatt HP0
- Pressure Equipment Directive 2014/68/EU
- Specialised Company for Welding ISO 3834-2
- Qualified Personnel for Material Traceability according §2 Abs.2a Gerätesicherungs-gesetz
- ATEX Directive 2014/34/EU



Validation for the Aseptic Diaphragm Valve

- Compliance to 3-A Standard Section 54-02
- Compliance of SED CDSA Design to EHEDG Hygienic Equipment Design Criteria Document No.8 SED CDSA
- Compliance to CRN Canadian Standards Association
- Certification of Compliance according to EN 10204 2.2
- Certification of Compliance according to EN 10204 3.1
- Certification of an assessment according 2014/34/EU
- TA-Luft / VDI 2440 / VDI 3479

Note: Certification and compliance for valve diaphragm and valve body see the corresponding sections in the catalogue

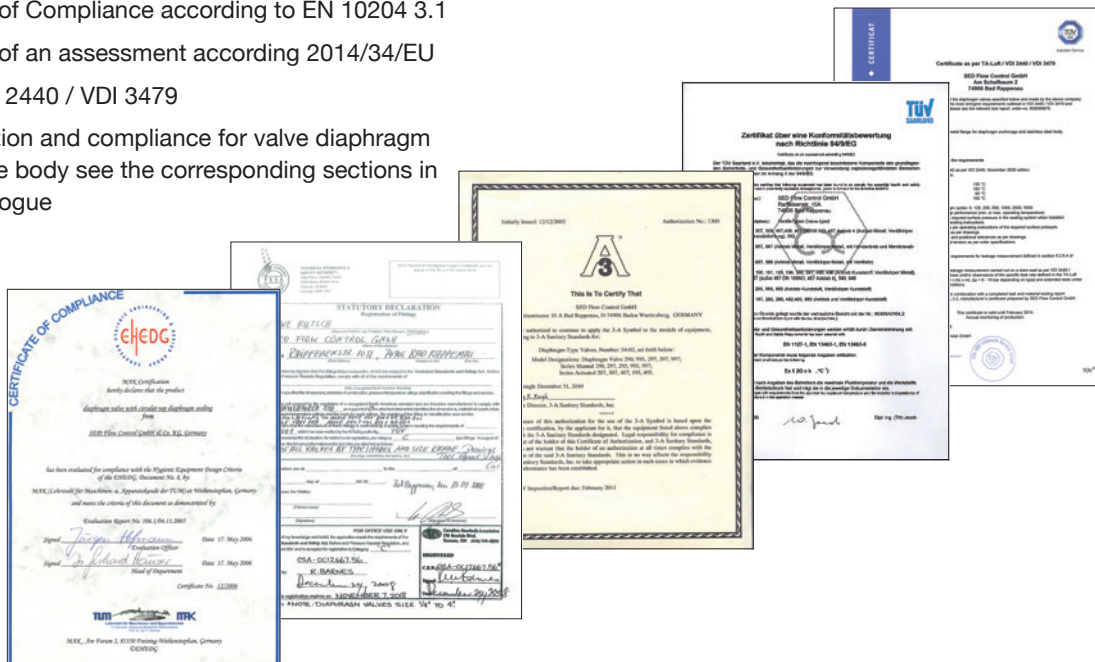

Flow Rate and Valve Sizing

In order to design valves for a process system correctly, the valve size is determined by the required flow rate. The K_V -value serves as a calculation basis for the different process conditions. This value is stated in the following table with regard to nominal diameter and standards.

K_V -value

The K_V -value is a parameter defining the flow rate of valves. It describes the amount of water from 5° to 30°C which flows through the valve at a pressure loss of 1 bar. The K_{VS} -value describes the K_V -value when the valve is 100% open.

For water 5-30°C applies:

$$K_V = \frac{Q}{\sqrt{\Delta p}}$$

General Liquid Flow Formula:

$$K_V = Q \sqrt{\frac{\rho}{1000 \Delta p}}$$



Test stand to determine and document flowrates and K_V (C_V) values

Conversion:

For the correct K_V to C_V conversion calculation, use only the stated units formulas below. The K_V -value must be converted from (cubic meter / hour) by utilizing the following conversion factors. In the US the flow rate of water is measured with the C_V -value in US-gallons per minute (gpm) with a pressure drop of Δp 1 PSI.

Conversion of K_V in C_V
 $C_V = 1,17 \times K_V$

Conversion of C_V in K_V
 $K_V = 0,86 \times C_V$

Explanations:

K_V m³/h flow rate parameter
 Q m³/h volume flow rate
 ρ kg/m³ specific gravity
 p_1 bar pressure before the valve
 p_2 bar pressure after the valve
 Δp bar pressure drop through the valve
 $\Delta p = p_1 - p_2$

K_{VS} -Value (m ³ /h)			Nominal diameter			Valve type
DN	NPS	MA	ISO 1127 Code 40	DIN 11850 Code 41-42	ASME-BPE Code 45	
4	-	8	-	-	-	190/207 290/297
6	-	8	-	-	-	
8	1/4	8	2,4	-	0,7	
10	3/8	8	-	2,3	1,4	
15	1/2	8	-	-	2,0	188/195/307 289/295/397
8	1/4	10	2,7	-	-	
10	3/8	10	3,9	2,5	1,4	
15	1/2	10	5,3	4,7	2,2	
20	3/4	10	-	5,5	4,6	385/395/402/407/495 905/982/985/995/997
15	1/2	25	10,5	9,5	-	
20	3/4	25	13,0	11,5	6,8	
25	1	25	15,5	14,2	12,0	
32	1 1/4	40	43,0	-	-	
40	1 1/2	40	50,0	43,0	40,0	
50	2	50	64,0	52,0	48,0	
65	2 1/2	80	95,0	89,0	85,0	
80	3	80	127,0	123,0	110,0	
100	4	100	205	192,0	185,0	

The K_{VS} -Values in the table refer to the specification with Two-Way valve bodies with EPDM diaphragm (Depending on the specification variations are possible).

The K_{VS} -Values with PTFE diaphragm maybe lower due to higher stiffness of the material, particularly in applications with lower working pressure.

Surface Finish

The consistency of the interior surface has a great impact on the quality of an aseptic system process. By means of polishing, the interior contact surface is reduced. The specified surface quality of the valve body is achieved through mechanical polishing and electro polishing. According to the standards SED offers surfaces with a surface finish up to a quality of 0,25 μm and 10 Ra. At SED the stated surface finish always describes the maximum surface roughness value.

The surface finish is reached by automatic or manual mechanical polish processing. The methods that are applied depend on the internal contour and size of the valve body.

The surfaces of the valve bodies with the highest quality are produced through polishing with different grit sizes up to size 400.

The advantages of premium surfaces are a smoother interior surface as well as the reduction of the contact between the surface and the process medium.

Thus a more efficient cleaning and sterilization, lower risk of contamination by process fluids, and lower danger of product adhesion to the interior surface is achieved.

Electro Polishing

Electro polishing is an electrochemical process where the polishing part serves as anode and for example, copper as electrode.

The valve body is submerged into an electrolyte solution and a voltage between 2 and 25 volts is charged. Through the current a strong chemical reaction develops which removes material from the anode.

According to the standardized procedure, the process has to be controlled in a way that at least 20 μm of surface material is removed.

The highest metal removal is achieved at the peaks of the metal surface.

Reasons for Electro Polishing

- High lustrous appearance
- Smoothing of the peaks of the surface finish
- Reduction of the surface tension and adhesion of the process medium
- Removal of non-metallic inclusions
- Improved corrosion resistance through accumulation of chromium of the surface

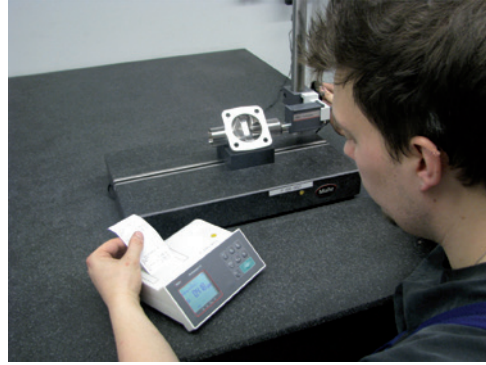

The surface finish, roughness, is measured and recorded at defined reference points according to DIN EN ISO 4287.

Microscopic view:

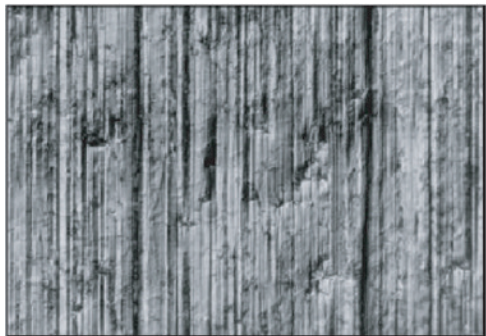

Microscopic view of mechanically polished surface with grit 400 Ra 0,25 μm / 10 $\mu\text{-inch}$

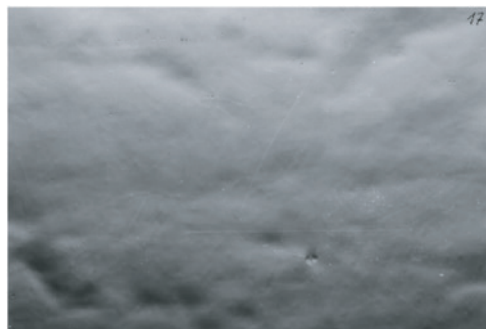

Microscopic view of mechanically polished and electro polished Ra 0,25 μm / 10 $\mu\text{-inch}$

Surface Finish

Ra-Value

The arithmetic average Ra is used as parameter for the surface finish profile.

$L_t = 5,6$ mm traversing length and $l_n = 4,0$ mm measuring range split in 5 single measuring sections $l_r = 0,8$ mm each measured transverse to the polished image.

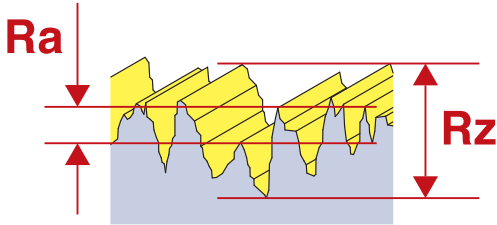

Definition of the SED codes for Ra-Values

Allocation to the standard DIN 11866:

SED		DIN 11866	Mechanically Polished	Mechanically Polished and Electro-polished
Code	Ra max	hygiene class		
02	0,8		•	
03	0,8	HE3c		•
07	0,6		•	
08	0,6			•
09	0,4		•	
10	0,4	HE4c		•
14	0,25		•	
16	0,25	HE5c		•

Allocation to the standard ASME BPE Table SF-2.4-1:

SED and ASME BPE	Ra max		Mechanically Polished	Mechanically Polished and Electro-polished
	μ-inch	μm		
SF0	No Finish Requirement			
SF1	20	0,51	•	
SF2	25	0,64	•	
SF3	30	0,76	•	
SF4	15	0,38		•
SF5	20	0,51		•
SF6	25	0,64		•

Tape Print Out of Surface Finish

```

Perthometer M1
Objekt
Name
#
Lt (AUTO)    5.600 mm
Lc           0.800 mm
Ra           0.484 μm
Rz           3.37 μm
Rmax         3.77 μm
R Pc(0.5,-0.5) 108 /c

R Profil
Lc           0.800 mm
VER          2.50 μm
    
```

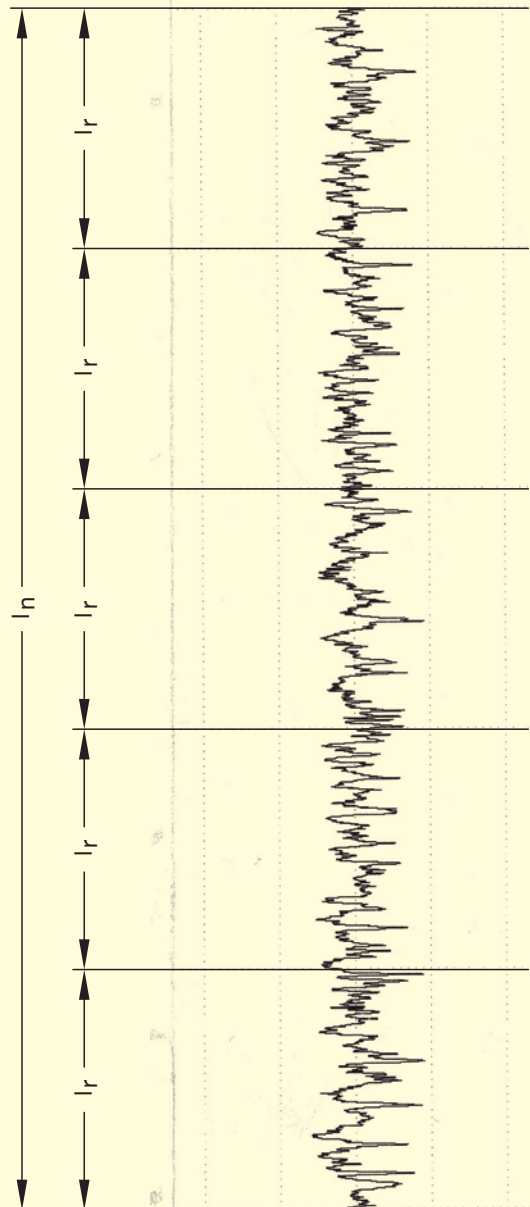

Table of Contents

1	Introduction A Brief Overview 4 The Company 5 What does Quality mean at SED? 6 General Information Testing 7 Qualification, Certification and Documentation 8 Flow Rate and Valve Sizing 9 Surface Finish 10, 11	Page
2	Media Contacted Components Diaphragms 14 - 19 Valve Bodies (fold out page) 20 Butt Weld Tube Ends (fold out page) 21 Aseptic Connections Clamps 22 Aseptic Flanges and Aseptic Threads 23	
3	Aseptic Diaphragm Valves Overview Diaphragm Aseptic Valves 26, 27 Why Aseptic Diaphragm Valve? 28 Self Draining - Two-Way Valve 29 Innovative Design 30 - 33 Aseptic Diaphragm Valves Aseptic Diaphragm Valve Manual 34 - 45 Aseptic Diaphragm Valve Pneumatically Operated 46 - 61 Ordering Key and Ordering Example 62, 63	
4	Aseptic Diaphragm Valve Configurations D-Rule 66 Welded Valve Configurations 67 - 69 Multiport Valves Why Multiport Valves? 70 Main line open, Loop Valves (e.g. T-Valve) 71 - 75 All lines and valve ports able to close 76 - 81 The way of customized multiport valve designs 82 Specification Multiport Valves 83 Tank Valves 84 - 87 Process Solutions Sterile Sampling Unit 88 Purified Steam Sampling Unit 89	
5	Angle Seat Valves Description and Features 92 Applications 93 Ordering Key and Ordering Example 94, 95 Technical Data 96 2/2-Way Angle Seat Valves 97 - 103 Valve Body Threaded Socket and Butt Weld End 104 Valve Body Clamp Socket and Flange 105	
6	System Components and Process Automation Overview 108 Manual Adjustment - Optical Indication 109 Electrical Switch Boxes - Pilot Control 110 Detailed Information 3/2 Way Plastic Pilot Valve Type 600 / 605 111 3/2 Way Plastic Pilot Valve Type 602 / 603 112 Control Head Switch 024.63. - 024.89. 113 Contact-Free Limit Switch 024.50 114, 115 Process Automation, Electropneumatic Positioners 116 - 118 Overview Product Range 119 Glossary 120, 121	

Diaphragms

The diaphragm is the most important component of the diaphragm valve.

Besides the valve body, the diaphragm is the only part which contacts the process medium.

The diaphragm separates the process medium from the actuator or top works and the external atmosphere.

In addition the diaphragm is the dynamic part which the flow rate of the process medium is controlled and stopped.

The developing of formulation of compound is done closely with a specialised company developing, producing and testing compounds since many years together with SED for our market.

The SED diaphragms have been developed and tested over years and are subject to stringent testing specification in our own test stands and third party. These tests are continuously performed with different specification to simulate as close as possible different real processes.

E.g. one of the testing is performed with a automatic saturated steam sterilisation loop. (see picture below).

The tests result has an influence on the design, composition of the materials, valve body design, actuation and complete valve assemblies.

All diaphragms are produced with an embedded stainless steel compressor stud for the engagement at the valve operating mechanism except for the diaphragm dimension MA8 which is connected with the valve activation by an elastomer button.

All diaphragm materials of the same size have the same engagement with the valve operating mechanism and may be interchanged in the valve without changing the diaphragm compressor and spindle.



Test stand sterilization process simulation. Cycle and lifetime testing of diaphragms and valves with saturated steam

Material		EPDM		PTFE/EPDM		PTFE/EPDM
MA		8 - 100		25, 40, 50	8, 10	25 - 100
Design		One-piece molded open		One-piece molded open		two-pieces molded closed
Temperature range	(°C)	-40 to 150		-20 to 150		-20 to 160
	(°F)	-40 to 300		-4 to 300		-4 to 300
SED Code		20	28	30	51	44

The listed temperatures may apply to clean steam sterilization protocols and may not apply to continuous steam service. Upon request, other diaphragms are available with other materials, bigger sizes and for higher temperature up to 175°C/350°F.

Diaphragms



Elastomer



PTFE/EPDM

EPDM

Ethylene-propylene elastomer peroxide cured. The SED EPDM is a specifically developed compound reinforced with a vulcanized woven fabric inlay and is always manufactured in the molded open position. This diaphragm construction achieves higher stability for the diaphragm at elevated temperatures and pressures. In addition, the woven fabric inlay is vulcanized over the embedded compressor stud in order to strengthen the elastomer-metal connection. Thus, the EPDM diaphragm is ideal for vacuum applications.

PTFE (TFM)

These PTFE diaphragms have been designed and offer the highest degree of chemical resistance, increased stability, longer flex life, less porosity, reduced cold flow and superior performance through temperature fluctuations between hot and cold and steam sterilization cycles.

MA8 and MA10

The diaphragm dimensions MA8 and MA10 are designed as one-piece diaphragms: This means that the EPDM back is bonded with the PTFE.

The diaphragm is always manufactured in the molded open position. These one-piece diaphragms have less surface area and are subject to shorter linear strokes which explain the excellent performance that has proved itself over time.

MA8 diaphragm incorporates an elastomer button for assembly with the valve operating mechanism. The MA10 utilizes a threaded stud assembly with the valve operating mechanism. Both these features eliminate the potential for point loading at the center of the diaphragm.

MA25 to MA100

The diaphragm dimensions MA25 to MA100 are designed as two-piece diaphragms-consisting of a separate EPDM backing cushion and PTFE diaphragm. The diaphragm is always manufactured in the molded closed position. The advantage of this design for the MA25 to MA100 is that the diaphragm is in its molded shape while in the closed position of the valve. This reduces the force to close the valve and increases the life of the diaphragm.

In the two piece diaphragms the threaded stud connection is embedded in the PTFE of the diaphragm. To eliminate the potential of point loading at the center of the diaphragm, a floating suspension connection to the valve operating mechanism is utilized.

Note: Other diaphragm sizes and materials on request.

Diaphragms

MA 8 - 80:

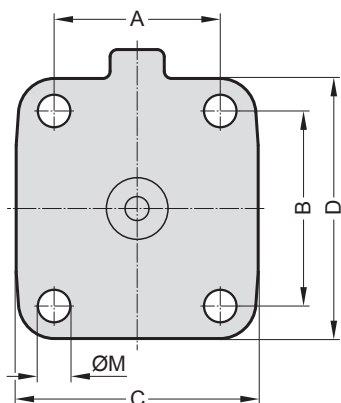

MA 100 - 125:

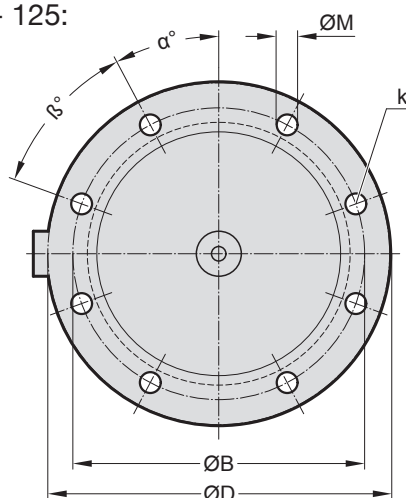

MA 150:

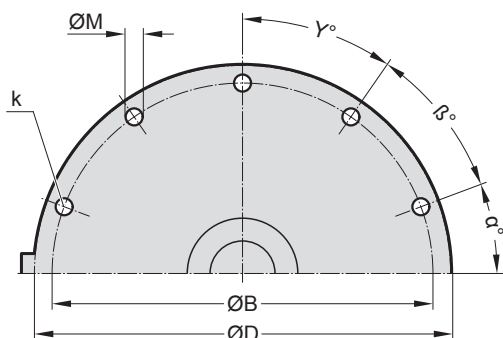

MA 10 - 150:

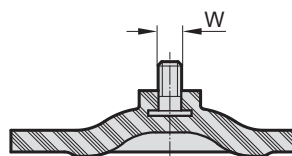

MA 8:

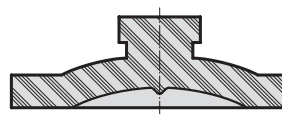

Dimensions (mm)

DN	NPS	MA	A	B	C	D	ØM	k	W	α	β	γ
4 - 15	1/4" - 1/2"	8	22	22	31,5	31,5	5,5	4	-	-	-	-
12 - 15	3/8" - 1/2"	10	42.5	37.5	52	47	5.5	4	M4	-	-	-
15 - 25	1/2" - 1"	25	46	54	67	72	9	4	1/4"	-	-	-
32 - 40	1 1/4" - 1 1/2"	40	65	70	90	100	13.5	4	1/4"	-	-	-
50	2"	50	78	82	106	124	13	4	1/4"	-	-	-
65	2 1/2"	65	95.3	101.6	131.9	144.4	14.3	4	5/16"	-	-	-
65 - 80	2 1/2" - 3"	80	114	127	156	186	18	4	5/16"	-	-	-
100	4"	100	-	194	-	228	14.5	8	5/16"	20	42	-
125	5"	125	-	222	-	254	17.5	8	3/8"	43.5	43.5	-
150	6"	150	-	273	-	298.5	17.5	10	3/8"	35	35	35

Diaphragms

Diaphragm Code 28

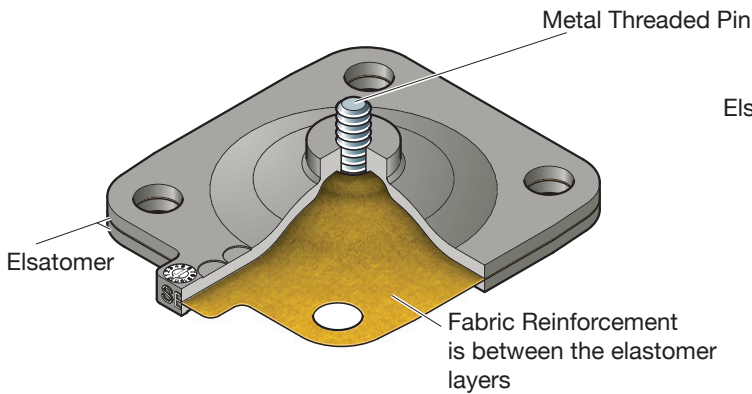

After a long and successful development accompanied by stringent testing, simulation of actual aseptic process applications and sterilization protocol, SED has released an improved elastomer formulation for our EPDM diaphragms. This EPDM diaphragm is produced out of an improved compound material targeting critical aseptic applications with SIP steam sterilizing cycles and processes.

Features:

- The elastomer formulation for our Code 28 EPDM diaphragm is identical to the Code 20 EPDM diaphragm which has a different design and manufacturing process.
- Woven fabric reinforcement is positioned between two elastomer layers.
- Increased lifetime expectancy under steam.
- All required approvals and conformities are available (See page 18).
- Diaphragm is interchangeable with all SED diaphragm valves.

Diaphragm Code 20

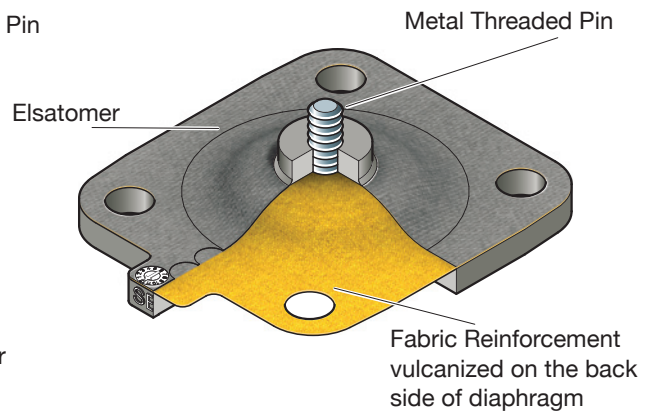

Typically a diaphragm is manufactured with a woven fabric reinforcement positioned in the middle of the EPDM elastomer diaphragm to improve the mechanical properties, strength and durability. This is accomplished by vulcanizing the woven fabric reinforcement between two elastomer layers.

A specific manufacturing process has been developed to vulcanize the woven fabric reinforcement on the back side of the EPDM diaphragm. With this manufacturing process the diaphragm achieves better performance in SIP steam sterilizing cycles and processes with reliability in critical sterile processes.

Features:

- The elastomer formulation for our Code 20 EPDM diaphragm is identical to the Code 28 EPDM diaphragm.
- The fabric has a maximum distance from the media contact surface.
 - Damage to the fabric can be easily observed.
- Friction between the compressor and the back of the diaphragm is minimized.
 - Therefore reduced wear and longer cycle lifetime.
- Better load distribution because the height of pure elastomer is maximized when the fabric is on the back side.
- Process safety increases because of only one fabric layer. The position of the fabric on the back side is exactly geometrically defined.
- Production control is easier when the fabric is on the back side.
- All required approvals and conformities are available (See page 18).
- Diaphragm is interchangeable with all SED diaphragm valves.

Diaphragms

Certification and Compliance for Validation

At SED, we recognize the importance of the validation process in the aseptic industry.

This has led to an internal awareness and specific restructuring within the company to provide the highest level of reliability and regulatory compliance through the complete supply chain to provide a complete package of documentation for all components in contact with the process fluid.

Related to it the key performance component in the diaphragm valve is the diaphragm.

- All resin and additives used in the manufacturing process are FDA compliant.
- Compounding, physical properties and manufacturing process are documented
- Certificate of Conformance with FDA for all diaphragms
 - 21CFR177.2600 for Elastomers
 - 21CFR177.1550 for Perfluorocarbon resins
- Certificate of Conformance with USP 28 Class VI, Chapter 87 In-Vitro and Chapter 88 In-Vivo
- Testing for extractable organic substances on the basis of ISO 10993-18 (detection by GC-MS)
- Certificate of Conformance with 3-A
- TSE/BSE (ADCF) Certification of Compliance to EMEA/410/01 "Guidance on Minimising the Risk of Transmitting Animal Spongiform Encephalopathy Agents via Human and Veterinary Medical Products"
- Certificate of Traceability according EN 10204 3.1 of compounding and molding process with material analysis
- Test data available upon request
- REACH-Verordnung (EU) 1907/2006/EG is observed
- RoHS Directive 2011/65/EU is observed

Code	Material	Menge	Einheit
1	21.3481	1.141	g
2	1.1.170	1	g
3	1.69.200	76.333	g
4	1.70.200	1.000	g
5	1.71.200	1.000	g
6	1.72.200	1.000	g
7	1.73.200	1.000	g
8	1.74.200	1.000	g
9	1.75.200	1.000	g
10	1.76.200	1.000	g
11	1.77.200	1.000	g
12	1.78.200	1.000	g
13	1.79.200	1.000	g
14	1.80.200	1.000	g
15	1.81.200	1.000	g
16	1.82.200	1.000	g
17	1.83.200	1.000	g
18	1.84.200	1.000	g
19	1.85.200	1.000	g
20	1.86.200	1.000	g
21	1.87.200	1.000	g
22	1.88.200	1.000	g
23	1.89.200	1.000	g
24	1.90.200	1.000	g
25	1.91.200	1.000	g
26	1.92.200	1.000	g
27	1.93.200	1.000	g
28	1.94.200	1.000	g
29	1.95.200	1.000	g
30	1.96.200	1.000	g
31	1.97.200	1.000	g
32	1.98.200	1.000	g
33	1.99.200	1.000	g
34	2.00.200	1.000	g
35	2.01.200	1.000	g
36	2.02.200	1.000	g
37	2.03.200	1.000	g
38	2.04.200	1.000	g
39	2.05.200	1.000	g
40	2.06.200	1.000	g
41	2.07.200	1.000	g
42	2.08.200	1.000	g
43	2.09.200	1.000	g
44	2.10.200	1.000	g
45	2.11.200	1.000	g
46	2.12.200	1.000	g
47	2.13.200	1.000	g
48	2.14.200	1.000	g
49	2.15.200	1.000	g
50	2.16.200	1.000	g
51	2.17.200	1.000	g
52	2.18.200	1.000	g
53	2.19.200	1.000	g
54	2.20.200	1.000	g
55	2.21.200	1.000	g
56	2.22.200	1.000	g
57	2.23.200	1.000	g
58	2.24.200	1.000	g
59	2.25.200	1.000	g
60	2.26.200	1.000	g
61	2.27.200	1.000	g
62	2.28.200	1.000	g
63	2.29.200	1.000	g
64	2.30.200	1.000	g
65	2.31.200	1.000	g
66	2.32.200	1.000	g
67	2.33.200	1.000	g
68	2.34.200	1.000	g
69	2.35.200	1.000	g
70	2.36.200	1.000	g
71	2.37.200	1.000	g
72	2.38.200	1.000	g
73	2.39.200	1.000	g
74	2.40.200	1.000	g
75	2.41.200	1.000	g
76	2.42.200	1.000	g
77	2.43.200	1.000	g
78	2.44.200	1.000	g
79	2.45.200	1.000	g
80	2.46.200	1.000	g
81	2.47.200	1.000	g
82	2.48.200	1.000	g
83	2.49.200	1.000	g
84	2.50.200	1.000	g
85	2.51.200	1.000	g
86	2.52.200	1.000	g
87	2.53.200	1.000	g
88	2.54.200	1.000	g
89	2.55.200	1.000	g
90	2.56.200	1.000	g
91	2.57.200	1.000	g
92	2.58.200	1.000	g
93	2.59.200	1.000	g
94	2.60.200	1.000	g
95	2.61.200	1.000	g
96	2.62.200	1.000	g
97	2.63.200	1.000	g
98	2.64.200	1.000	g
99	2.65.200	1.000	g
100	2.66.200	1.000	g

Diaphragms

Diaphragm Traceability

All diaphragms are clearly identified and the material is batch traceable by a set of unique codes molded into the diaphragm body.

Information provided on the order and shipping documents as well as on the packaging is described by the following. With the request of the Material Analysis Traceability Certificate DIN EN 10204 3.1 for manufacturing and formulation the additionally provided information is shown in bold type.

... on the order and shipping documents:

- SED article number, material code with description
- Customer article number on request
- **Batch number**
- **Shelf Life**

... on packaging in which the diaphragm is bagged and sealed in plastic:

- SED article number, material code with description
- Internal order series number
- Packaging quantity
- Customer article number on request
- **Batch number**
- **Shelf Life**

Example markings MA8

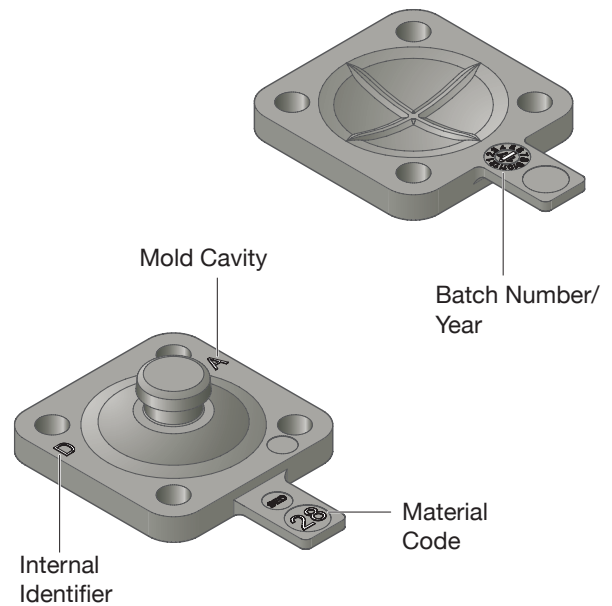

Example markings MA50

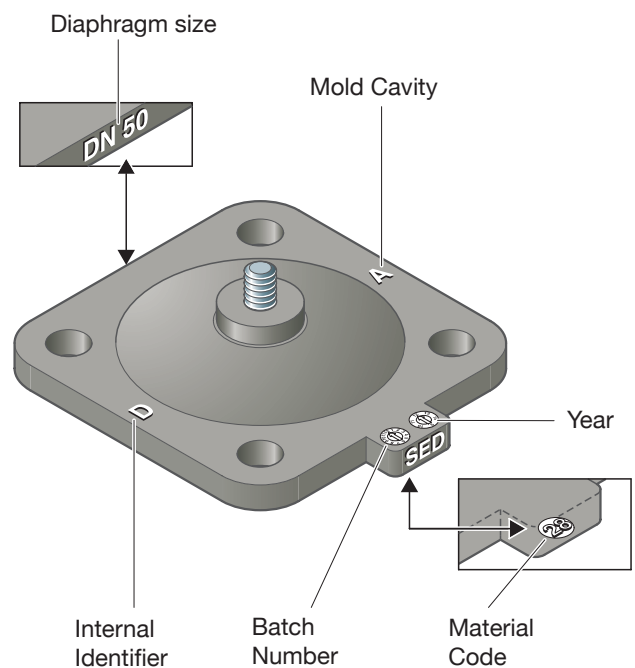

Valve Bodies

The SED valve bodies as standard are manufactured of the material 1.4435 / S31603 ASME BPE Table MM-2.1-1 and according to EN 10204 inspection certificate 3.1/ Material Test Report (MTR). All valve bodies contain a stamped heat number that allows for traceability to the material properties and physical composition of the valve body. The interior body contour and contact surfaces are designed specifically to comply with the requirements of cGMP. Optimized cleanability and a cavity-free design eliminate entrapment areas and enhance diaphragm life. The SED valve bodies are produced out of raw forged, block material, or investment cast. Depending on the material and specification of the valve body, different manufacturing processes are used.

Forged Bodies

The forged body begins from a solid piece of stainless steel ingot. In the forging process the shape of the material is changed through pressure between forging tools at elevated temperatures.



Through the forging procedure a high density and homogeneous structure of the material is obtained. This reduces the possibility of porosity or that any inclusions can emerge. After that, the forged body is mechanically machined according to the specification.

Block Bodies

When producing bodies made of solid wrought block or bar stock material you obtain equal features to that of forgings. The individual raw valve bodies are cut from the block or bar stock and then are mechanically machined according to the specification. All the finished bodies can be supplied with a Delta Ferrite content of less than 0.5%.

Tube End Standards

The following chart of international standards of pipe diameters identifies the different diameters comparing the example of a nominal diameter of DN 25.

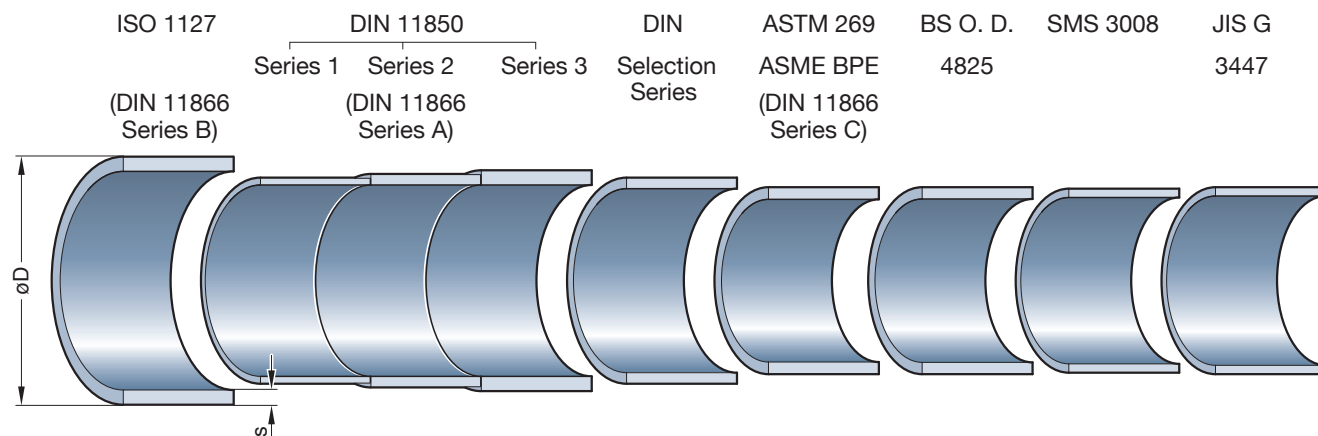

Investment Cast

The investment cast bodies are produced in a pattern filled with wax containing the shape of the final valve body. By dipping the wax formed body in a ceramic material, the complete wax valve body is covered with ceramic. After melting the interior wax body, the ceramic shell is filled with molten stainless steel. The surrounding ceramic coating is removed and a very high dimensional accuracy and a clean and smooth surface results. In order to achieve a high quality investment cast products, SED patterns are designed and optimized for high quality castings. The bodies are checked according to detailed test specifications to ensure a reliable quality regarding the material structure and density.

Component	Tube Size	Manufacturing Process
2/2 way body	4 - 80 mm / 1/4 - 3"	forged
	100 - 150 mm / 4 - 6"	block material
	4 - 100 mm / 1/4 - 4"	investment cast
Multiport body	4 - 150 mm / 1/4 - 6"	block material
Tank valve	4 - 150 mm / 1/4 - 6"	block material

Chemical Composition

Values listed in this Table are primary elements only and are not complete chemical compositions as listed in specific product type material specifications.

Element	1.4435 Wt. %
Carbon, max.	0,030
Manganese, max.	2,00
Chromium	17,00-19,00
Nickel	12,50-15,00
Molybdenum	2,50-3,00

According ASME BPE Table MM-2.1-1 alloy comparable with material S31603 and listed in previous versions of ASME BPE as 316L.

Sulfur content ASME BPE always within 0,005 to 0,017.

Other alloys are available on request, below is a list of materials machined from solid block:

- Super-Austenitic Stainless Steel
- Duplex Stainless Steel
- Nickel Alloys
- Titanium

Butt Weld Tube Ends

SED offers tube end outside diameter and wall thickness dimensions in accordance to the several international standards. These standards and dimensions are listed in the below table.

In order to install a proper aseptic process piping system, it is important that the correct and consistent international tube end standards be followed throughout the aseptic process piping system. If the connecting tube ends are not identical and of the same diameter standard, there may

result a reduction or step in the process piping system or the ability of self draining ends is not guaranteed.

The most common standard connection is the butt-welding of the tube endings without any additional material.

Examples of butt welding include automatic and orbital welding.

Besides the standard any customer-specified connection type is possible.

Some examples are displayed on the following pages.

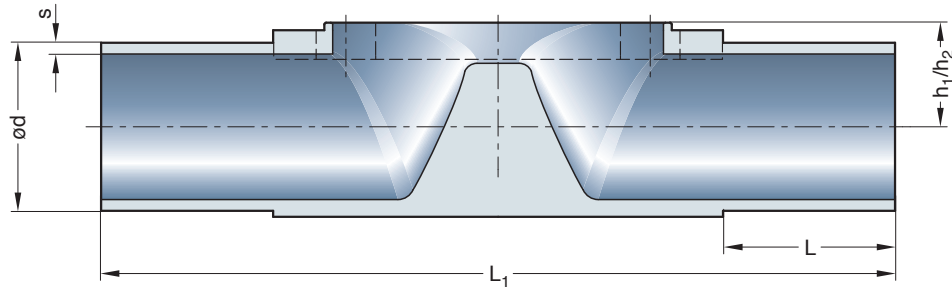

h_1 = Investment cast bodies
 h_2 = forged bodies

Butt weld Tube End Standard	ISO 1127	DIN 11850		DIN	ASTM 269	BS O.D.	SMS	JIS G	JIS G
	DIN 11866 Series B	Series 1	Series 2	Selection Series	ASME BPE	4825	3008	3447	3459
Code	40	41	42	39	45 ¹	94	49	97	98 ³
DN NPS MA L _(min) L ₁ h ₁ h ₂	$\varnothing d \times s$	$\varnothing d \times s$	$\varnothing d \times s$	$\varnothing d \times s$	$\varnothing d \times s$	$\varnothing d \times s$	$\varnothing d \times s$	$\varnothing d \times s$	$\varnothing d \times s$

Valve Type Manually Operated 290 / 297											
Valve Type Pneumatically Operated 190 / 207											
4	-	8	20	72	9	9	-	-	-	-	-
6	-	8	20	72	9	9	-	-	8x1,0 ²	8x1,0	-
8	1/4	8	20	72	9	9	13,5x1,6	-	10x1,0 ²	10x1,0	6,35x0,89
10	3/8	8	20	72	9	9	-	12x1,0	13x1,5	-	9,53x0,89
15	1/2	8	20	72	9	9	-	-	-	-	12,7x1,65

Valve Type Manually Operated 289 / 295 / 397											
Valve Type Pneumatically Operated 188 / 195 / 307 / 392											
8	-	10	25	108	12	12	13,5x1,6	-	-	-	-
10	3/8	10	25	108	12	12	17,2x1,6	12x1,0	13x1,5	-	9,53x0,89 ³
15	1/2	10	25	108	12	12	21,3x1,6	18x1,0	19x1,5	18x1,5	12,7x1,65
20	3/4	10	25	108	12	12	-	-	23x1,5	22x1,5	19,05x1,65

Valve Type Manually Operated 905 / 982 / 985 / 995 / 997											
Valve Type Pneumatically Operated 385 / 395 / 402 / 407 / 495 / 592											
15	-	25	25	120	13	16	21,3x1,6	18x1,0	19x1,5	-	12,7x1,65 ³
20	3/4	25	25	120	16	16	26,9x1,6	22x1,0	23x1,5	-	19,05x1,65
25	1	25	25	120	19	19	33,7x2,0	28x1,0	29x1,5	28x1,5	25,4x1,65
32	1 1/4	40	25	153	24	26	42,4x2,0	34x1,0	35x1,5	-	31,75x1,65 ³
40	1 1/2	40	25	153	24	26	48,3x2,0	40x1,0	41x1,5	-	38,1x1,65
50	2	50	30	173	32	32	60,3x2,0	52x1,0	53x1,5	-	50,8x1,65
65	2 1/2	50	30	173	32	32	-	-	-	-	63,5x1,65
65	2 1/2	80	25	216	47	47	76,1x2,0	-	70x2,0	-	63,5x1,65
80	3	80	30	254	47	47	88,9x2,3	-	85x2,0	-	76,2x1,65
100	4	100	30	305	61	58	114,3x2,3	-	104x2,0	-	101,6x2,11
125	5	125	30	450	100	90	139,7x2,6	-	129x2,0	-	-
150	6	150	30	450	100	96	168,3x2,6	-	154x2,0	-	152,4x2,77

Dimensions in mm; MA = Diaphragm size / Upon request, other tube end standards are available / Preferred standards bold

¹ ASTM 269 ASME BPE tube diameter (Code 45) in forged version optional also available in tube end length according ASME BPE (Code 95); Tube Size 1/4" to 2 1/2" L = 1,5" (38,1 mm); Tube Size 3" L = 1,75" (44,45 mm); Tube Size 4" L = 2" (50,8 mm); Tube Size 6" L = 2,5" (63,5 mm)

² DIN 11866 only

³ Available only in forged design

Aseptic Connections

Clamps

The clamp connection is the most popular connection for easy assembly and breakdown of process lines and valves. The clamp end connection is designed for a face-to-face joint that is leak proof and free of crevices.

The clamp end has a machined beveled seat and is used with specifically formed sealing gaskets made of EPDM or PTFE.

The gasket is inserted between the opposing clamp ends and is compressed tight with a wing nut quick disconnect clamp.

In general, the valve clamp ends are welded to the valve butt weld ends and polished according to the specified interior valve body surface finish.

The welded clamp ends are 100% visually inspected and compression tested. The clamp connections are available for all current pipe standard diameters.

If the connecting clamp ends are not identical and of the same diameter standard, there may result a reduction or step in the process piping system or the ability of self draining ends is not guaranteed.

If assembled correctly, the clamp end process system offers a smooth, crevice-free, self-aligning joint that reduce the hazards of contamination but minimize turbulence and pressure drop through the system.

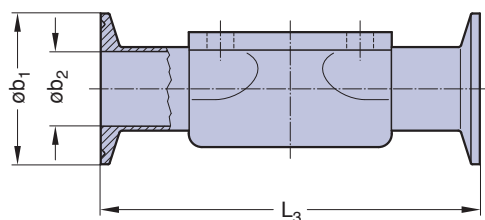

Dimensions Inch

Clamp End Ident. Tube End Ident.			ASME BPE ASME BPE			ASME BPE ASME BPE		
Code FtF			645			545		
Standard FtF			DIN EN 558-1			ASME BPE DT-V-1		
DN	NPS	MA	L ₃	b ₂	b ₁	L ₃	b ₂	b ₁
8	1/4	8	-	-	-	2,5	0,18	1
10	3/8	8	-	-	-	2,5	0,31	1
15	1/2	8	2,5	0,37	1	2,5	0,37	1
10	3/8	10	-	-	-	-	-	-
15	1/2	10	4,25	0,37	1	3,5	0,37	1
20	3/4	10	4,60	0,62	1	4,0	0,62	1
15	1/2	25	4,25	0,37	1	4,0	0,37	1
20	3/4	25	4,60	0,62	1	4,0	0,62	1
25	1	25	5,00	0,87	2	4,5	0,87	2
32	1 1/4	40	-	-	-	-	-	-
40	1 1/2	40	6,25	1,37	2	5,5	1,37	2
50	2	50	7,50	1,87	2,5	6,25	1,87	2,5
65	2 1/2	80	8,50	2,37	3	*8,75	2,37	3
80	3	80	10,00	2,87	3,5	8,75	2,87	3,5
100	4	100	12,00	3,83	4,5	11,5	3,83	4,5

Dimensions mm

Clamp End Ident. Tube End Ident.			Similar ISO 2852 ISO 1127			DIN 32676 DIN 11850			ASME BPE ASME BPE			ASME BPE ASME BPE			SMS 3017 SMS 3008		
Code Face to face (FtF)			640			641/642			645			545			649		
Standard FtF			DIN EN 558-1			DIN EN 558-1			DIN EN 558-1			ASME BPE DT-4.4.1-1			DIN EN 558-1		
DN	NPS	MA	L ₃	b ₂	b ₁	L ₃	b ₂	b ₁	L ₃	b ₂	b ₁	L ₃	b ₂	b ₁	L ₃	b ₂	b ₁
8	1/4	8	*63,5	10,3	25,0	-	-	-	-	-	-	63,5	4,57	25,0	-	-	-
10	3/8	8	-	-	-	*63,5	10,0	34,0	-	-	-	63,5	7,75	25,0	-	-	-
15	1/2	8	-	-	-	-	-	-	*63,5	9,40	25,0	63,5	9,40	25,0	-	-	-
10	3/8	10	108	14,0	25,0	108,0	10,0	34,0	-	-	-	-	-	-	-	-	-
15	1/2	10	108	18,1	50,5	108,0	16,0	34,0	108,0	9,40	25,0	88,9	9,40	25,0	-	-	-
20	3/4	10	-	-	-	-	-	-	117,0	15,75	25,0	101,6	15,75	25,0	-	-	-
15	1/2	25	108	18,1	50,5	108,0	16,0	34,0	108,0	9,40	25,0	101,6	9,40	25,0	-	-	-
20	3/4	25	117	23,7	50,5	117,0	20,0	34,0	117,0	15,75	25,0	101,6	15,75	25,0	-	-	-
25	1	25	127	29,7	50,5	127,0	26,0	50,5	127,0	22,10	50,5	114,3	22,10	50,5	127,0	22,6	50,5
32	1 1/4	40	146	38,4	50,5	146,0	32,0	50,5	-	-	-	-	-	-	146,0	31,3	50,5
40	1 1/2	40	159	44,3	64,0	159,0	38,0	50,5	159,0	34,80	50,5	139,7	34,80	50,5	159,0	35,6	50,5
50	2	50	190	56,3	77,5	190,0	50,0	64,0	190,0	47,50	64,0	158,8	47,50	64,0	190,0	48,6	64,0
65	2 1/2	80	216	72,1	91,0	216,0	66,0	91,0	216,0	60,20	77,5	*222,3	60,20	77,5	216,0	60,3	77,5
80	3	80	254	84,3	106,0	254,0	81,0	106,0	254,0	72,90	91,0	222,3	72,90	91,0	254,0	72,9	91,0
100	4	100	305	109,7	130,0	305,0	100,0	119,0	305,0	97,38	119,0	292,1	97,38	119,0	305,0	97,6	119,0

*Length differing from standard; other lengths on request

Aseptic Connections

Aseptic Flanges

Aseptic flanges according to DIN 11864-2 Form A are connections with a partly open o-ring for optimized cleaning features and a reduced dead leg. The round flange and the groove flange are welded with the pipe ends and the weld seam is polished according to the specified interior valve body surface finish.

The connections are available for the current pipe standards within the aseptic application. The round flange and the groove flange are welded orbital with the pipe endings and the weld seam is polished mechanically according to the valve body.

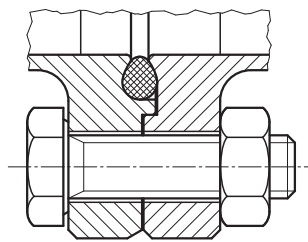
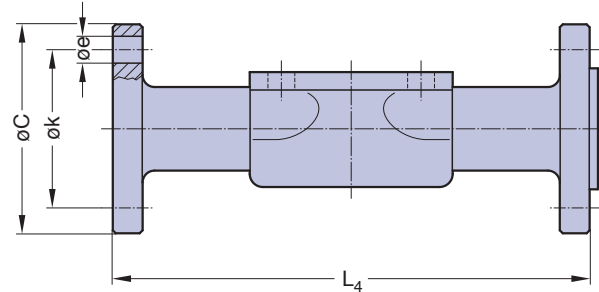
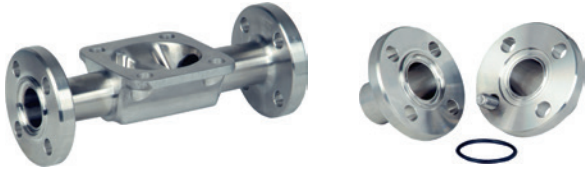

			DIN 11864-2-A Code 3.. (mm)			
DN	NPS	MA	L ₄	C	k	e
10	3/8	10	130	54	37	ø 9
15	1/2	25	130	59	42	ø 9
20	3/4	25	150	64	47	ø 9
25	1	25	160	70	53	ø 9
32	1 1/4	40	180	76	59	ø 9
40	1 1/2	40	200	82	65	ø 9
50	2	50	230	94	77	ø 9
65	2 1/2	80	290	113	95	ø 9
80	3	80	310	133	112	ø 11
100	4	100	350	159	137	ø 11

Aseptic Threads

Threaded spigot, liner and the interjacent seal are compressed with a spigot nut.

The connections are available for the current pipe standards within the aseptic application.

- Milk-threaded ends DIN 11851 with form sealing
- Aseptic connection according to DIN 11864-1 A with partly open o-ring for optimized cleaning features and a reduced dead leg. The threaded spigot, the liner and the interjacent o-ring are compressed against a metallic block with a spigot nut.

The threaded spigot and liner are welded with the pipe ends and the weld seam is polished according to the specified interior valve surface finish.

L in mm			DIN 11851 Code 8..		DIN 11864-1-A Code 4..	
DN	NPS	MA	L ₂	G	L ₂	G
4	-	8	-	-	-	-
6	-	8	-	-	-	-
8	1/4	8	-	-	-	-
10	3/8	8	92	Rd 28 x 1/8	92	Rd 28 x 1/8
15	1/2	8	-	-	-	-
8	1/4	10	-	-	-	-
10	3/8	10	118	Rd 28 x 1/8	118	Rd 28 x 1/8
15	1/2	10	118	Rd 34 x 1/8	118	Rd 34 x 1/8
20	3/4	10	-	-	-	-
15	1/2	25	118	Rd 34 x 1/8	120	Rd 34 x 1/8
20	3/4	25	118	Rd 44 x 1/6	144	Rd 44 x 1/6
25	1	25	128	Rd 52 x 1/6	164	Rd 52 x 1/6
32	1 1/4	40	147	Rd 58 x 1/6	192	Rd 58 x 1/6
40	1 1/2	40	160	Rd 65 x 1/6	214	Rd 65 x 1/6
50	2	50	191	Rd 78 x 1/6	244	Rd 78 x 1/6
65	2 1/2	80	246	Rd 95 x 1/6	314	Rd 95 x 1/6
80	3	80	256	Rd 110 x 1/4	342	Rd 110 x 1/4
100	4	100	-	-	-	Rd 130 x 1/4

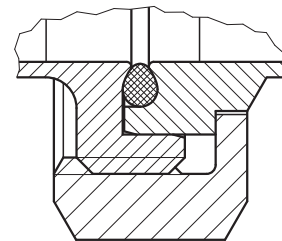
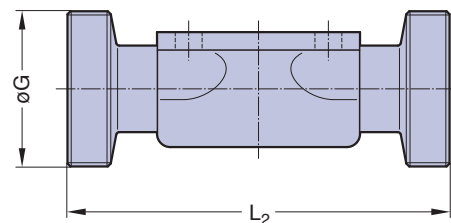

DIN 11864-1-A

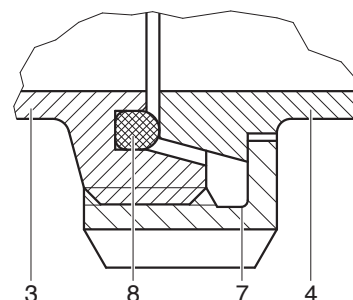









DIN 11851



Table of Contents

1	Introduction	Page
	A Brief Overview	4
	The Company	5
	What does Quality mean at SED?	6
	General Information	
	Testing	7
	Qualification, Certification and Documentation	8
	Flow Rate and Valve Sizing	9
	Surface Finish	10, 11
2	Media Contacted Components	
	Diaphragms	14 - 19
	Valve Bodies (fold out page)	20
	Butt Weld Tube Ends (fold out page)	21
	Aseptic Connections	
	Clamps	22
	Aseptic Flanges and Aseptic Threads	23
3	Aseptic Diaphragm Valves	
	Overview Diaphragm Aseptic Valves	26, 27
	Why Aseptic Diaphragm Valve?	28
	Self Draining - Two-Way Valve	29
	Innovative Design	30 - 33
	Aseptic Diaphragm Valves	
	Aseptic Diaphragm Valve Manual	34 - 45
	Aseptic Diaphragm Valve Pneumatically Operated	46 - 61
	Ordering Key and Ordering Example	62, 63
4	Aseptic Diaphragm Valve Configurations	
	D-Rule	66
	Welded Valve Configurations	67 - 69
	Multiport Valves	
	Why Multiport Valves?	70
	Main line open, Loop Valves (e.g. T-Valve)	71 - 75
	All lines and valve ports able to close	76 - 81
	The way of customized multiport valve designs	82
	Specification Multiport Valves	83
	Tank Valves	84 - 87
	Process Solutions	
	Sterile Sampling Unit	88
	Purified Steam Sampling Unit	89
5	Angle Seat Valves	
	Description and Features	92
	Applications	93
	Ordering Key and Ordering Example	94, 95
	Technical Data	96
	2/2-Way Angle Seat Valves	97 - 103
	Valve Body Threaded Socket and Butt Weld End	104
	Valve Body Clamp Socket and Flange	105
6	System Components and Process Automation	
	Overview	108
	Manual Adjustment - Optical Indication	109
	Electrical Switch Boxes - Pilot Control	110
	Detailed Information	
	3/2 Way Plastic Pilot Valve Type 600 / 605	111
	3/2 Way Plastic Pilot Valve Type 602 / 603	112
	Control Head Switch 024.63. - 024.89.	113
	Contact-Free Limit Switch 024.50	114, 115
	Process Automation, Electropneumatic Positioners	116 - 118
	Overview Product Range	119
	Glossary	120, 121

Overview Aseptic Valves

Series	Description	Specification			
Steripur Stainless Steel Actuation	Control function available	Manual			
	Diaphragm size	MA 8	MA 10	MA 25 - 50	MA 80 - 100
	Diameter in mm (inch)	4 - 15 (1/4 - 1/2)	8 - 20 (3/8 - 3/4)	15 - 50 (3/4 - 2 1/2)	65 - 100 (2 1/2 - 4)
	Type	297	397	997	
	Image				
	Max. working pressure with - diaphragm EPDM in bar (psi)	10 (150)	10 (150)	10 (150)	10 (150)
	- diaphragm PTFE in bar (psi)	10 (150)	10 (150)	10 (150)	8 (115)
	Max. working temperature °C (°F) ²	160 (320)			
	Details see page	34, 35	36, 37	38, 39	

KMA Actuation with Stainless Steel Bonnet	Control function available	Manual			
	Diaphragm size	MA 8	MA 10	MA 25 - 50	MA 80 - 100
	Diameter in mm (inch)	4 - 15 (1/4 - 1/2)	8 - 20 (3/8 - 3/4)	15 - 50 (3/4 - 2 1/2)	65 - 100 (2 1/2 - 4)
	Type	290	295	905	995
	Image				
	Max. working pressure with - diaphragm EPDM in bar (psi)	10 (150)	10 (150)	10 (150)	10 (150)
	- diaphragm PTFE in bar (psi)	10 (150)	10 (150)	10 (150)	8 (115)
	Max. working temperature °C (°F) ²	160 (320)			
	Details see page	35	36, 37	40, 41	42





KMD Plastic Actuation directly mounted	Control function available	Manual		
	Diaphragm size	MA 10	MA 25 - 50	MA 80 - 100
	Diameter in mm (inch)	8 - 20 (3/8 - 3/4)	15 - 50 (3/4 - 2 1/2)	65 - 100 (2 1/2 - 4)
	Type	289	982	985
	Image			
	Max. working pressure with - diaphragm EPDM in bar (psi)	6 (87)	10 (150)	10 (150)
	- diaphragm PTFE in bar (psi)	6 (87)	10 (150)	8 (115)
	Max. working temperature °C (°F), design HS ²	150 (300)	NA	NA
	Max. working temperature °C (°F), design S ²	80 (176)		
Details see page	36, 37	44, 45	43	





² dependent on application



MA = Diaphragm size

Differentiations between the series see table page 30

Overview Aseptic Valves

Specification					Series
Pneumatically operated					Steripur Stainless Steel Actuation
NC	NC, NO, DA				
MA 8		MA 10	MA 25 - 50	MA 80 100	
4 - 15 (1/4 - 1/2)		8 - 20 (3/8 - 3/4)	15 - 50 (3/4 - 2 1/2)	65 - 100 (2 1/2 - 4)	
207.25	207.30	307 ¹	407 ¹	407 ¹	
					
4,5 (65)	8 (115)	8 (115)	10 (150)	7 (100) 6 (87)	
4 (60)	7 (100)	7 (100)	8 (115)	6 (87) 5 (72)	
160 (320)					
46, 47		49	52, 53		

Pneumatically operated				KMA Actuation with Stainless Steel Bonnet
NC, NO, DA				
MA 8	MA 10	MA 25 - 50	MA 25 - 50 80 100	
4 - 15 (1/4 - 1/2)	8 - 20 (3/8 - 3/4)	15 - 50 (3/4 - 2 1/2)	15 - 100 (3/4 - 4)	
190	195	395	495	
				
8 (116)	8 (116)	10 (150)	10 (150) 7 (100) 6 (87)	
7 (100)	7 (100)	8 (115)	8 (115) 6 (87) 5 (72)	
160 (320)				
48	50	55	54	

Pneumatically operated			KMD Plastic Actuation directly mounted
NC, NO, DA			
MA 10	MA 25 - 50	MA 25 - 50 80	
8 - 20 (3/8 - 3/4)	15 - 50 (3/4 - 2 1/2)	15 - 100 (3/4 - 4)	
188	402	385	
			
8 (115)	10 (150)	10 (150) 7 (100)	
7 (100)	8 (115)	8 (115) 6 (87)	
150 (300)	150 (300)	NA	
80 (176)	NA	80 (176)	
51	57	56	

¹ available also with two-stage actuator, see page 58 to 60

Why Aseptic Diaphragm Valve?

The standard valve assembly consists of three components: the valve body, the diaphragm and the actuation. Due to its unique characteristics, the diaphragm valve has prevailed for aseptic processes. Demanding requirements for higher quality in process applications is proceeded by our developing innovative and advanced solutions. SED's priority is to commit the resources needed and achieve high quality standards based on continuous developments beneficial for the customer's application. These developments provide the latest applied knowledge and standards, the requirement of compliances, and recommendations of the admission organizations.

General and SED Specific Criteria:

- **Positive Closure**
The resilient diaphragm bead in contact with the metal weir assures positive closure.
- **Ideal for CIP and SIP**
Clean-in-place and Steam-in-place operations may be performed in-line without valve disassembly or operation.
- **In-Line Maintenance**
The top entry design allows for in-line maintenance.
- **Bonnet Isolation**
The diaphragm isolates the working parts of the valve from the process media.
- **Streamline Fluid Passage**
A smooth contoured body, streamlined flow path and high quality interior surface prevents the accumulation of process fluids or contaminants.
- **Minimal Contact Surfaces**
The process contact surfaces (body and diaphragm) are minimal, enhancing the ease of cleaning and sterilization.
- **One Centerline for Inlet and Outlet**
One centerline for inlet and outlet simplifies installation and plant design work.
- **Modular Construction System**
Modular valve construction system reduces complexity and maintenance expense.

Working Pressure from One and Both Sides for Pneumatic Operation

(see illustration on the right)

The reference to the maximum possible working pressure in this catalogue is only valid for uni-directional media with a pressure drop ($\Delta p = 100\%$) independent from the flow direction. Uni-directional working pressure corresponds to most applications.

If the media pressure is simultaneously the same on both sides ($\Delta p = 0\%$) i. e. due to a certain applications of the valve in a loop installation, please ask a factory representative for the maximum possible working pressure or to specify for the correct layout of the valve.

If the sum of the two pressures does not exceed the maximum possible working pressure from one side, the valve can be applied for that application.

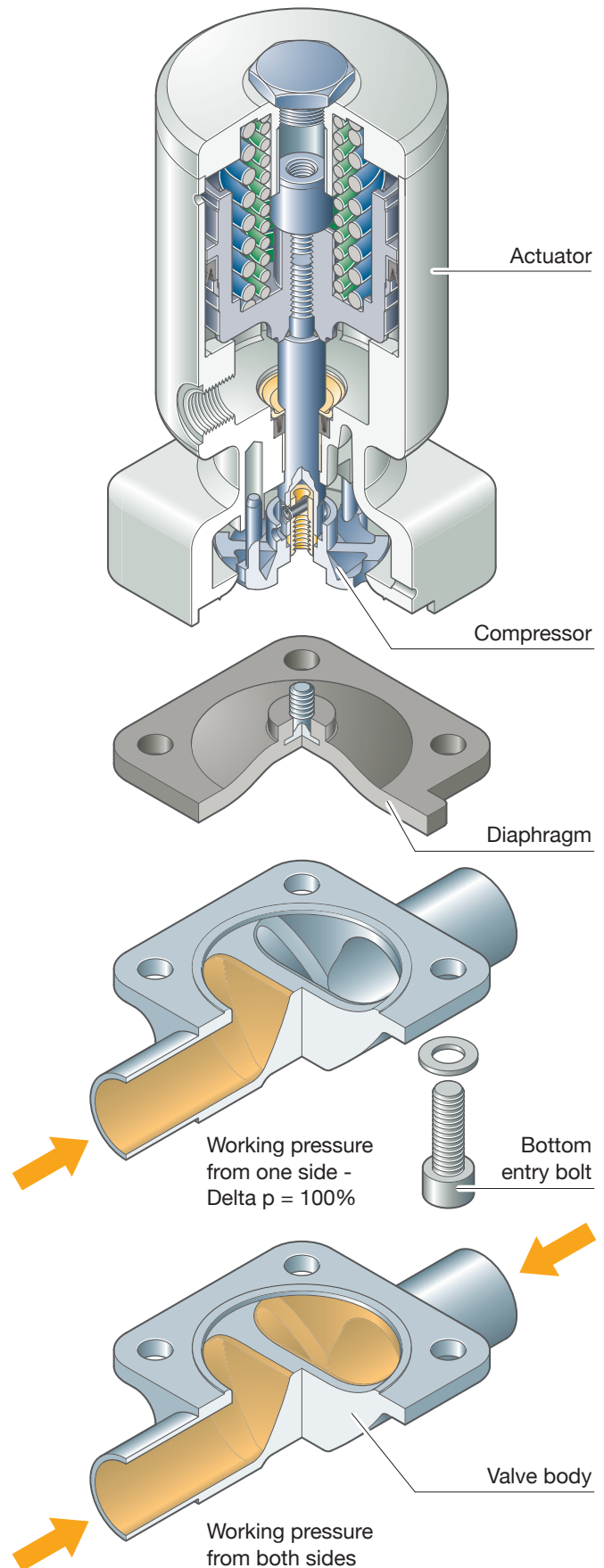

Self Draining - Two-Way Valve

One of the most important criteria of all valves applied in aseptic processes is the drainability. This feature has contributed substantially why the diaphragm valve has prevailed as the valve of choice for aseptic process applications.

To achieve optimum self draining for horizontal installed valves, the following criteria are relevant:

- Correct design and inner contours of the two-way body
- Internal surface quality of the two-way body
- Cavity free valve assembly
- Self draining installation position
- End connections
- Slope of the installed two-way body
- Consistency of the media

It is essential that the valve be installed at the specific angle allowing the media to fully drain in the open position. See the illustration below and the corresponding table showing the specific angle depended on tube size, standard, as well as the material selection of the two-way body. For optimum drainability it is recommended to install the tubing and valves with about 1% (10 mm/m) slope for long runs and 2% (20 mm/m) slope for short runs. This is recommended to ensure the complete drainability of the process system. Drainability in the process system is ultimately the responsibility of the system designer and/or end user. Upon request, the tube end of the valve body is marked with a hash mark. If installed correctly, the hash mark must vertically cross the centerline of the tube end and be perpendicular to the pipe line. In addition, a template may be supplied for easy installation and adjustment of the drain angle.

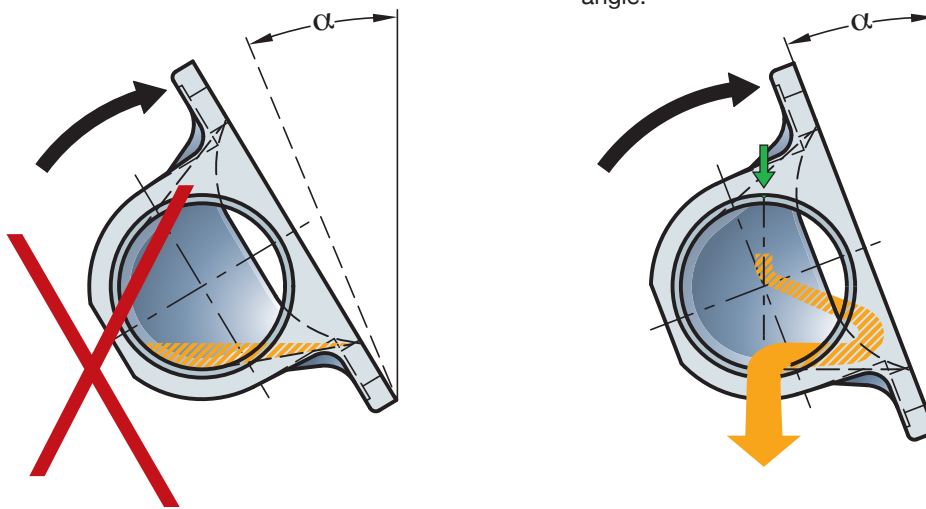

VALVE-TYPE	VALVE SIZE			SELF DRAINING ANGLE					
	Tube end standard			FORGED BODIES			INVESTMENT CAST BODIES		
				ISO 1127	DIN 11850-1/-2	ASME BPE	ISO 1127	DIN 11850-1/-2	ASME BPE
	Code			DIN 11866-B	DIN 11866-A	DIN 11866-C	DIN 11866-B	DIN 11866-A	DIN 11866-C
DN (mm)	NPS (inch)	MA	α (Degree)			α (Degree)			
190 / 207 290 / 297	4	-	8	-	-	-	-	22	-
	6	-	8	-	-	-	-	22	-
	8	1/4	8	20,5	-	33,2	12,5	22	42
	10	3/8	8	-	22,4	28,4	-	13,5	28,5
	15	1/2	8	-	-	25	-	-	15,5
188 / 195 289 / 295 307 / 392 397	8	-	10	26,6	-	-	31	-	-
	10	3/8	10	20,6	27,5	31,4	21	32	-
	15	1/2	10	12,8	17,3	28,8	10,5	16	33
	20	-	10	-	9,6	17,4	-	7	16,5
385 / 395 / 402 407 / 495 592 / 905 / 982 995 / 995 / 997	15	1/2	25	33,5	35,8	42,9	39,5	43	-
	20	-	25	27,3	31,5	36,1	29	36	43,5
	25	1	25	15,7	19,9	29,1	20	26	32,5
	32	1 1/4	40	18,4	23,9	26,8	21	28,5	-
	40	1 1/2	40	12,3	17,7	21,5	14	21	25
	50	2	50	12,4	16,1	18,5	13,5	19,5	22,5
	65	2 1/2	50	-	-	12,4	23	30	9
	65	2 1/2	80	21,1	23,3	26,6	23	30	30
	80	3	80	15,8	15,8	21,1	17	17	23
100	4	100	17,1	18	19,3	19,5	19,5	19,5	

MA = Diaphragm size
 Drain angle tolerance is +/- 2 degrees for optimum drainability
 All valve bodies are marked with the valid self draining angle.

Innovative Design

SED offers three different series of manual and pneumatically operated aseptic diaphragm valves. The selection of each is influenced by different criteria, i. e. application, technical specification, process system and plant design, available space, and last but not least the TCO (total cost of ownership).

The following table shows an overview of the performance and features of the three different series: Steripur, KMA, and KMD.

This table can support your decision which makes it easy to find the optimum solution for your application.

Position	Series MA Performance Features	Steripur			KMA			KMD	
		8	10	≥ 25	8	10	≥ 25	10	≥ 25
1	Stainless steel piston actuation	●	●	●					
2	Actuation with stainless steel bonnet or distance piece				●	●	●		
3	Plastic actuation direct mounted to the valve body							●	●
4.1	Compact Design	●	●	●		●	Type 395 / 905	●	Type 402
4.2	Optional orientation of the air inlet port	●	●	●	●		Type 395	●	Type 402
5	Actuation for two-way bodies and welded configurations	●	●	●	●	●	●	●	●
6	Actuation suitable for two-way bodies, welded configurations, T-bodies, multiport bodies and tank bottom bodies	●	●	●	●	●	●		
7	Optimized internal cleaning because of circumferential defined sealing angle between process diaphragm and valve body (CDSA-Design)	●	●	●	●	●	●	●	●
8	Clean and smooth exterior ideal for sterile wash downs Bold bottom entry	●	●	●				●	●
9	Flexible diaphragm suspension	●	●	●	●	●	●	●	●
10	Encapsulated working diaphragm		●	●		●	●	●	●
11	Low weight						Type 395 / 905	●	●

MA = Diaphragm size

Positions 4 to 11 are explained individually and in detail on pages 31 to 33.

Innovative Design

Compact Design - Optional Orientation of the Air Inlet Port

(Position 4 in Table page 30)

The selection of the valve is determined by the necessary flow rate from which the nominal diameter of the valve is determined. Due to physical limitations of space and the principle of the valve designs, the ability to improve the compactness of the valve assemblies is with the actuators. The innovative designs of SED valve actuators offer specific advantages.

New process system and plant design standards require dead legs to be minimized. Dimensions of valve assemblies have significance if it affects dead legs in the process system which must be minimized as much as possible. When selecting welded configurations and multiport valves, the actuators size plays an important role in minimizing dead legs.

SED offers actuators in a compact design with the following features:

- The outside diameter of the actuators is the same size or smaller as the bonnet flange of the body. The bonnet encapsulates the diaphragm and connects the diaphragm, actuator and body.
- The direction of the control air connection (air inlet port) for the valve actuation can be orientated either in the flow direction or 90° to the flow direction.

It is possible to combine any different actuation models.



Actuation for Two-Way Bodies and Welded Configurations

Actuation suitable for Two-Way Bodies, Welded Configurations, T-Bodies, Multiport Bodies and Tank Bottom Bodies

(Position 5 and 6 in Table page 30)

Dependent on the valve body design two different ways of valve assembly are possible.

- Bottom Entry Assembly
Two-way bodies and two-way body welded configurations allow for this kind of assembly. The advantage is having no bolt holes in the actuator and therefore no exposed parts like bolt threads, nuts, and washers. Ease of assembly for maintenance. This is the ideal design for sterile wash downs.

- Through Bolt Hole Actuator Assembly
Through bolt hole assembly is suitable for all body versions, two-ways, welded configurations, T-bodies, multiport, and tank bottom bodies. Through bolt holes are not possible in some valve body designs because of interference with the interior flow path. Therefore the holes are drilled in the actuators and assembled with stud bolts threaded into the valve body.



MZ - Multiport Valve
T-valve with U-bend and sample valve
Main valve KMA Series pneumatically operated
Sample valve Steripur Series manual



T-Valve
Steripur Series
Pneumatically operated



Two-Way Valve
Steripur Series
Manual

Innovative Design

Optimized Internal Cleaning because of Circumferential Defined Sealing Angle (CDSA-Design) between the Process Diaphragm and Valve Body

(Position 7 in Table page 30)

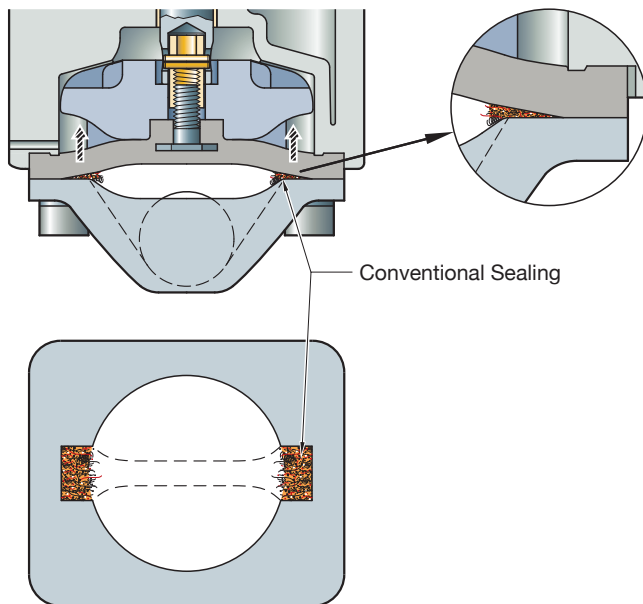

To achieve the highest level of sterility, the SED CDSA-Design Series was developed by utilizing new, qualified, and tested diaphragm valve technology. This unique design of the actuator reduces or eliminates product entrapment at the point beyond the radius of the weir on the body bonnet flange.

The CDSA sealing concept is achieved by the compressor being guided by the interior circular actuator lower housing providing a circumferential defined sealing angle at 360°. This reduces or eliminates entrapment because the seal over the weir and the circumference of the interior valve body is at the point and angle where the diaphragm and valve body meet.

The conventional weir style design in the market does not provide this feature because the interior actuator lower housing has guidance for the compressor. Typically, these compressors are designed with ends or fingers that extend beyond the radius of the weir onto the internal bonnet flange. Therefore, a circumferential defined sealing angle is not possible.

The effects of this design have the following advantages:

- Internal cleaning is more efficient and has been tested and qualified by EHEDG Document No. 08.
- Product entrapment reduced or eliminated on the body bonnet flange.
- Reduced cleaning time of SIP systems.
- Reduced use of chemicals and solutions in CIP systems.
- Improves valve drainability.
- Better sealing performance and evenly distributed closing force.
- Diaphragm lifetime is extended.

The same selection of diaphragms may be used for all SED series and versions of actuators.

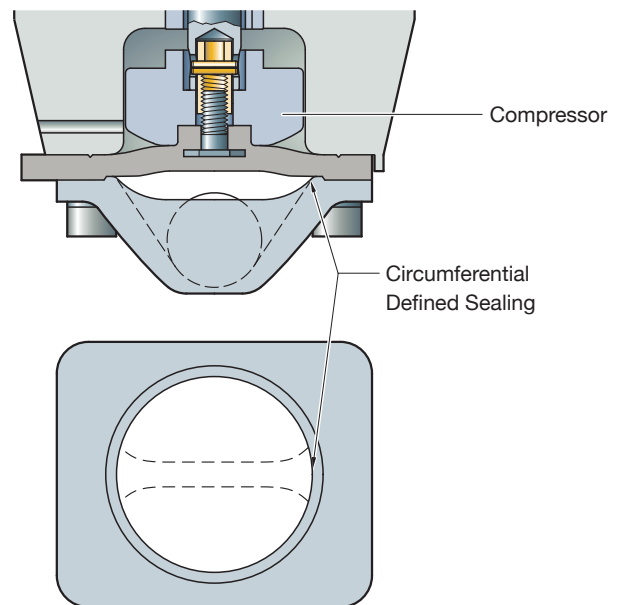

Clean and Smooth Exterior Ideal for Sterile Wash Downs

(Position 8 in Table page 30)

The exterior design of the SED valve Steripur Series and KMD is ideal for cleaning and sterile wash downs. Because of bottom entry assembly with tapped threads in the actuator, there are no exposed parts.

In addition, this design eliminates pockets, cut-outs, strengthening ribs, edges, sharp corners and rough surfaces.

(For a better understanding compare examples on page 52, 53 - Type Steripur 407 and page 54 - Type KMA 495).

Innovative Design

Flexible Diaphragm Suspension

(Position 9 in Table page 30)

The flexible diaphragm suspension has different relevant performance depending on the selection of diaphragm material and type. The proper selection of diaphragm materials, type, and actuator components can eliminate point loading at center of the diaphragm. Point loading reduces the cycle life time of the diaphragm.

The smallest diaphragm size MA8 incorporates an elastomer button that is pressed into the compressor for connecting the diaphragm to the actuator. Because of the resilient elastomer material, it provides a flexible suspension throughout all the MA8 versions.

All other SED sizes have a threaded diaphragm stud for assembly to the spindle of the actuator. With the elastomer and one piece PTFE diaphragm versions, the threaded stud is vulcanized into the resilient elastomer material. This connection reduces the risk of point loading if properly assembled.

The two-piece PTFE and elastomer diaphragms have the threaded diaphragm stud embedded in the PTFE material. Point loading in center of the diaphragm in this case is almost unavoidable, resulting in diaphragm failure.

To eliminate point loading, SED supplies the flexible suspensions as standard for all valves that offer the option of using the two-piece diaphragm. The flexible diaphragm suspension assures that the closing force of the diaphragm will be absorbed by the elastomer of the diaphragm and the force evenly distributed across the weir of the body.

All of the SED diaphragms have the same assembly engagement by size regardless of the actuation or diaphragm materials and type. This is a tremendous advantage for diaphragm changes and replacement. There are systems in the market, i.e. bayonet connection and floating tube nut which require changing the spindle or compressor for different diaphragm materials and type.

This is not necessary with SED, select the valve and actuator and you may change to any of the SED diaphragm options without any additional parts or components.

The flexible diaphragm suspension is produced from a two-piece spindle in order to provide the necessary tolerance and scope between the two pieces. (See below illustration).

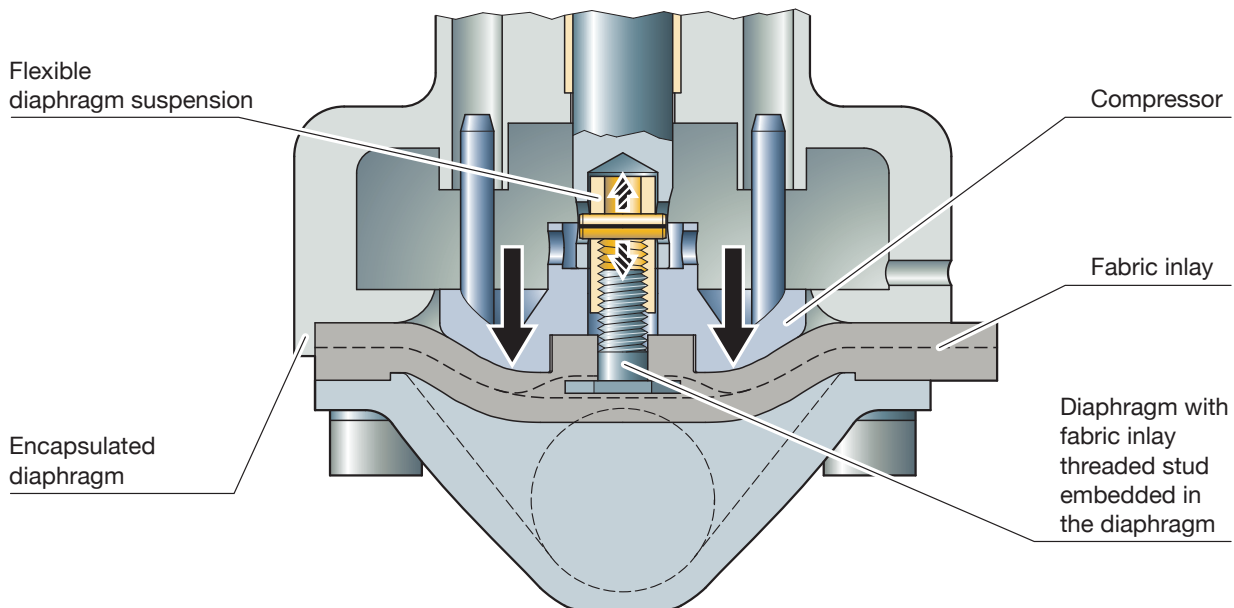

Encapsulated Working Diaphragm

(Position 10 in Table page 30)

All SED actuators partially encapsulate the process diaphragm.

This prevents the elastomer of the diaphragm from extruding beyond the body bonnet flange.

The encapsulated diaphragm offers a positive visual appearance of an assembled valve and reduces the risk of leakage to the exterior through the decrease of the diaphragm clamping. This is an important feature especially for higher temperature and pressure applications.

Steripur 297

Manual Valve DN 4 - 15 mm (1/4" - 1/2")

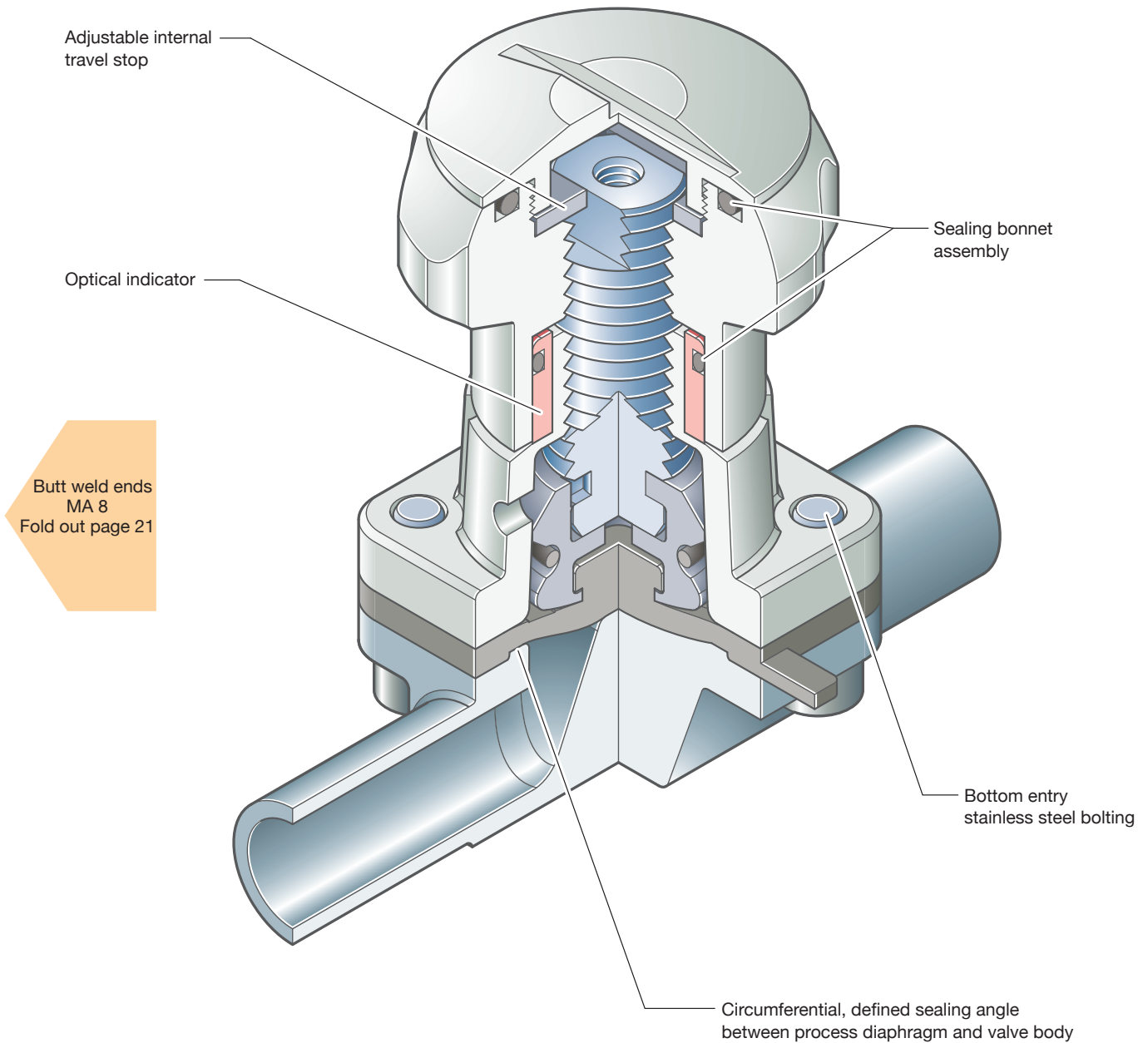

Sectional drawing shows Steripur 297

Steripur 297 / KMA 290

Manual Valve DN 4 - 15 mm (1/4" - 1/2")



Steripur 297

Specific Features

Type 297 Steripur

- Stainless steel bonnet and hand wheel
- Autoclavable

Type 290 KMA

- Stainless steel bonnet and plastic hand wheel
- Manual diaphragm Valve with plastic hand wheel is suitable for a limited number of cycles of autoclaving.

General Features

Rising hand wheel

- Sealed bonnet with optical indicator
- Adjustable internal travel stop
- CDSA sealing concept, see page 32
- Flexible diaphragm suspension

Optional

Type 297 Steripur

- Locking device

Technical Data

Control function: Manually operated

Max. working pressure: 10 bar (150 psi)

Max. working temperature: 160°C (320°F) dependent on application

Diaphragm material: EPDM or PTFE

Body material: Forged 1.4435/ 316L ASME/BPE

Investment cast 1.4435/ 316L

Other Alloys

End connection: Butt weld ends see fold out page 21

Clamps and flanges see page 22 and 23

Special ends

Bonnets suitable for: Two-Way bodies

Welded configurations

T- bodies

Multiport bodies

Tank bottom bodies

Flow rate: Kv in m³/h (Cv in GPM) see page 9

Diaphragm size: MA 8

Weight: 290: ca. 0,2 kg

297: ca. 0,3 kg

Technical data also valid for multiport valve.

Butt weld ends
MA 8
Fold out page 21



KMA 290

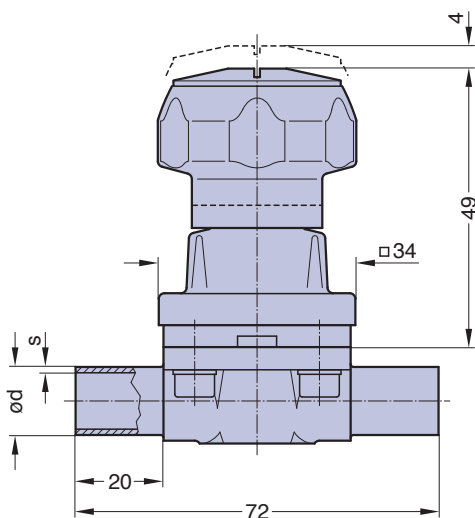

Steripur 297

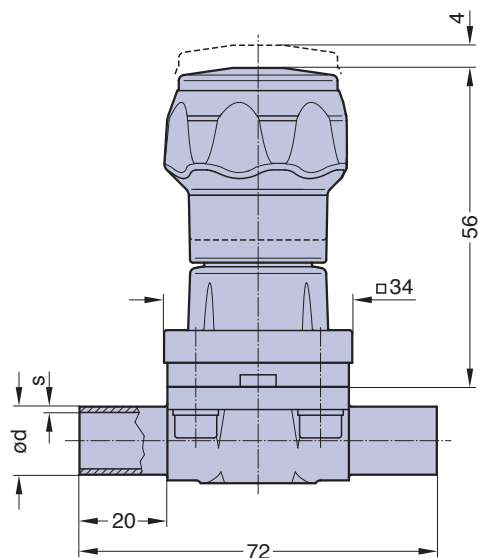

KMA 290

Valve type overview see page 26 and 27.
Ordering key see page 62 and 63.

Steripur 397 / KMA 295 / KMD 289

Manual Valve DN 8 - 20 mm (3/8" - 3/4")

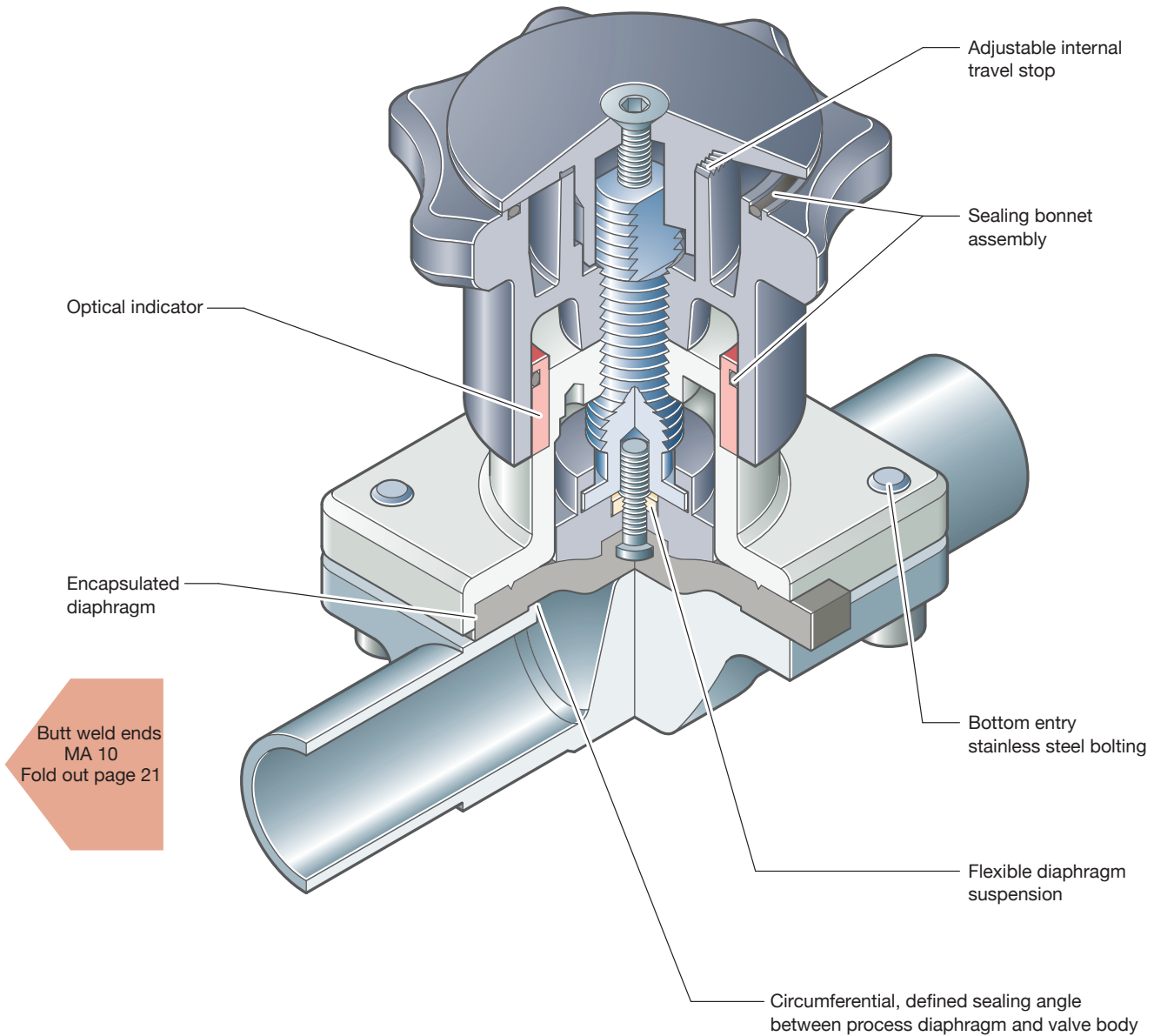

Sectional drawing shows KMA 295

Steripur 397 / KMA 295 / KMD 289

Manual Valve DN 8 - 20 mm (3/8" - 3/4")



Steripur 397



KMA 295



KMD 289

Butt weld ends
MA 10
Fold out page 21

Specific Features

Type 397 Steripur

- Stainless steel bonnet and hand wheel
- Autoclavable

Type 295 KMA

- Stainless steel bonnet and plastic hand wheel
- Manual diaphragm Valve with plastic hand wheel is suitable for a limited number of cycles of autoclaving.

Type 289 KMD

- Plastic bonnet and hand wheel

General Features

- Rising hand wheel
- Sealed bonnet with optical indicator
- Adjustable internal travel stop
- CDSA sealing concept, see page 32
- Flexible diaphragm suspension
- Encapsulated diaphragm

Optional

Type 397 Steripur

- Locking device

Technical Data

Control function:	Manually operated
Max. working pressure:	Type 295, 397: 10 bar (150 psi) Type 289: 6 bar (87 psi)
Max. working temperature:	Type 295, 397: 160°C (320°F) dependent on application Type 289 S-Version: 80°C (176°F) dependent on application Type 289 HS-Version: 150°C (300°F) dependent on application
Diaphragm material:	EPDM or PTFE
Body material:	Forged 1.4435/ 316L ASME/BPE Investment cast 1.4435/ 316L Other Alloys
End connection:	Butt weld ends see fold out page 21 Clamps and flanges see page 22 and 23 Special ends
Bonnets suitable for:	Two-Way bodies / Welded configurations T- bodies / Multiport bodies Tank bottom bodies
Flow rate:	Kv in m ³ /h (Cv in GPM) see page 9
Diaphragm size:	MA 10
Weight:	289: ca. 0,5 kg 295: ca. 0,6 kg 397: ca. 0,8 kg

Technical data also valid for multiport valve.

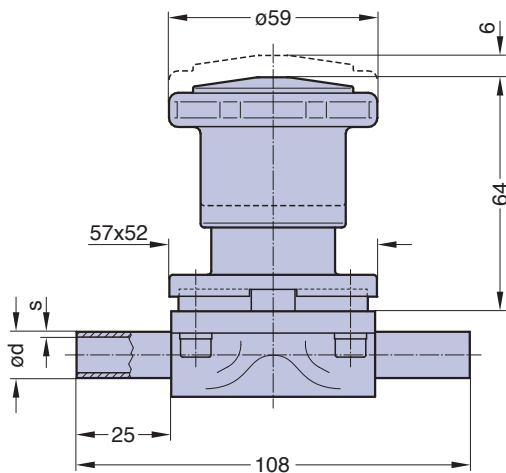

KMA 295 and Steripur 397

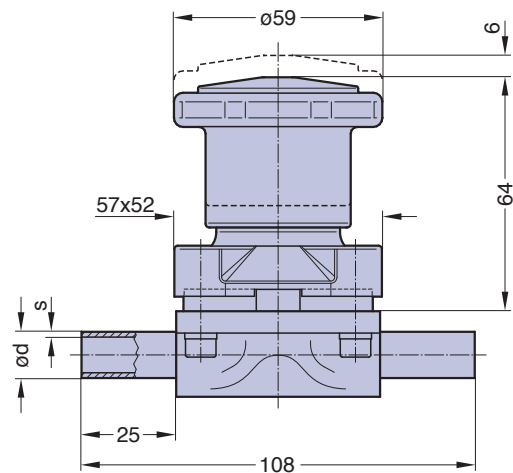

KMD 289

Valve type overview see page 26 and 27.
Ordering key see page 62 and 63.

Steripur 997

Manual Valve DN 15 - 100 mm (3/4" - 4")

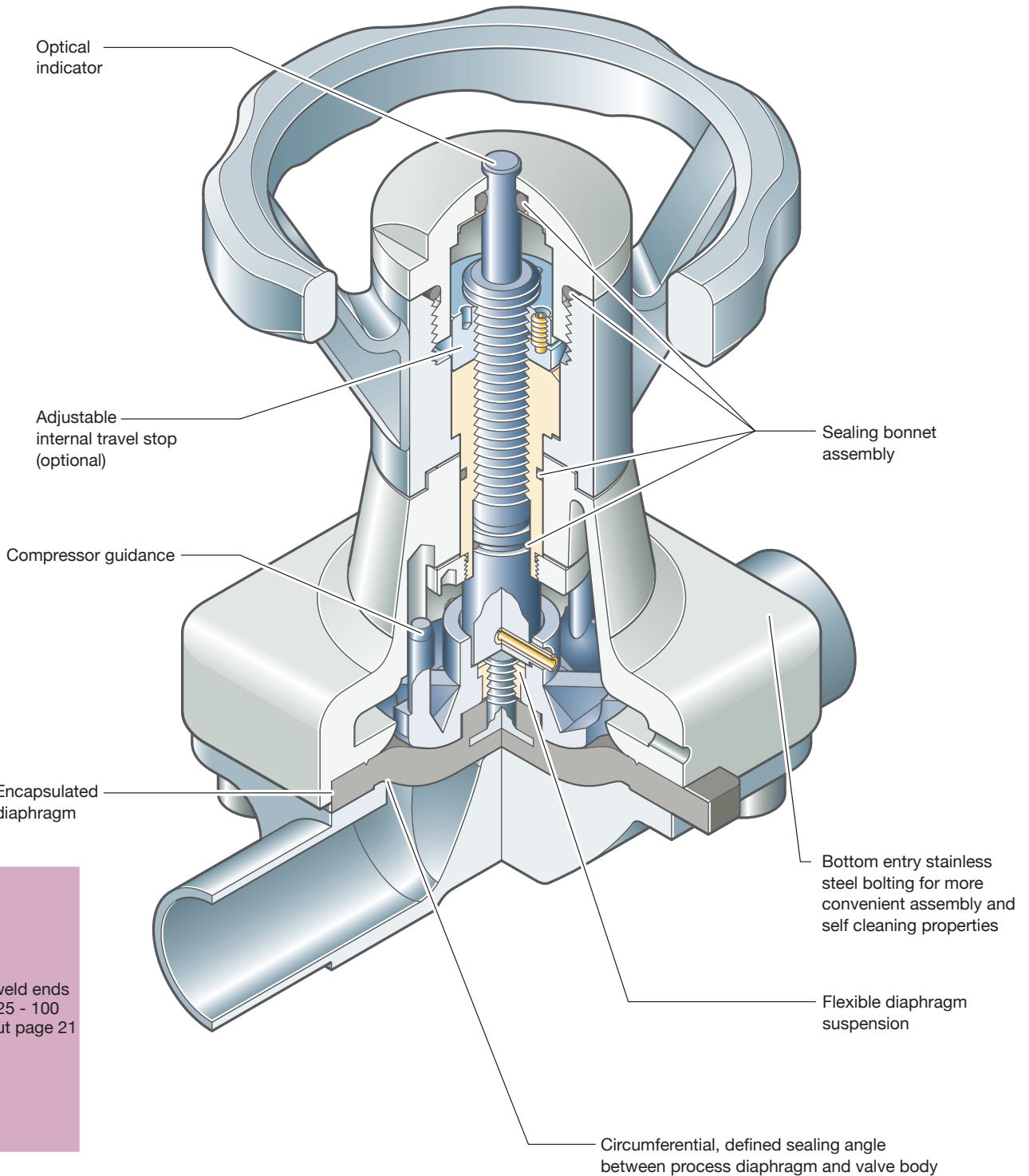

Butt weld ends
MA 25 - 100
Fold out page 21

Steripur 997

Manual Valve DN 15 - 100 mm (3/4" - 4")



Features

- Stainless steel bonnet and hand wheel
- Non rising hand wheel with optical indicator
- Sealed bonnet
- Autoclavable
- CDSA sealing concept, see page 32
- Flexible diaphragm suspension
- Encapsulated diaphragm

Optional

- Adjustable internal travel stop or stroke limiter

DN 15 - 50

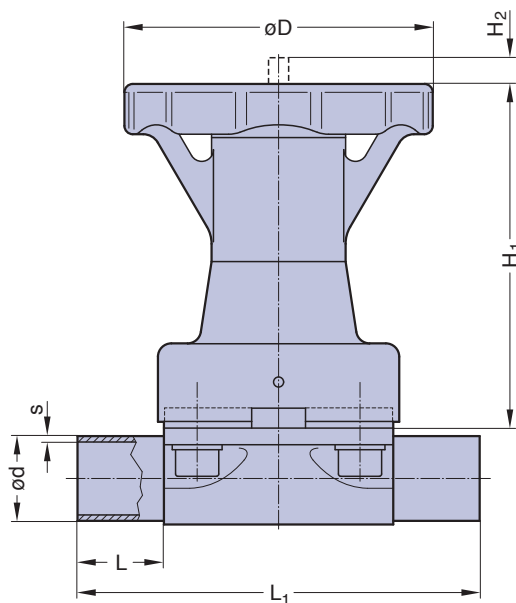

DN 15 - 50

Technical Data

- Control function: Manually operated
 Max. working pressure: 10 bar (150 psi)
 DN 65-100 diaphragm PTFE 8 bar (115 psi)
 Max. working temperature: 160°C (320°F) dependent on application
 Diaphragm material: EPDM or PTFE
 Valve body material: Forged 1.4435/ 316L ASME/BPE
 Investment cast 1.4435/ 316L
 Other Alloys
 End connection: Butt weld ends see fold out page 21
 Clamps and flanges see page 22 and 23
 Special ends
 Bonnets suitable for: Two-Way bodies
 Welded configurations
 T- bodies
 Multiport bodies
 Tank bottom bodies
 Flow rate: Kv in m³/h (Cv in GPM) see page 9
 Diaphragm size: MA see table
 Technical data also valid for multiport valve.

DN (mm)	MA	Dimensions (mm)					Total weight ca. (kg)	
		L	L ₁	H ₁	H ₂	D	Investment cast	Forged
15-25	25	25	120	103	10	92	1,8	1,9
32-40	40	25	153	135	17	135	4,0	4,2
50	50	30	173	135	24	135	8,0	9,0
65	80	30	216	180	38	198	13,0	15,0
80	80	30	254	180	38	198	13,0	15,0
100	100	30	305	220	50	252	22,0	20,0

Butt weld ends
 MA 25 - 100
 Fold out page 21

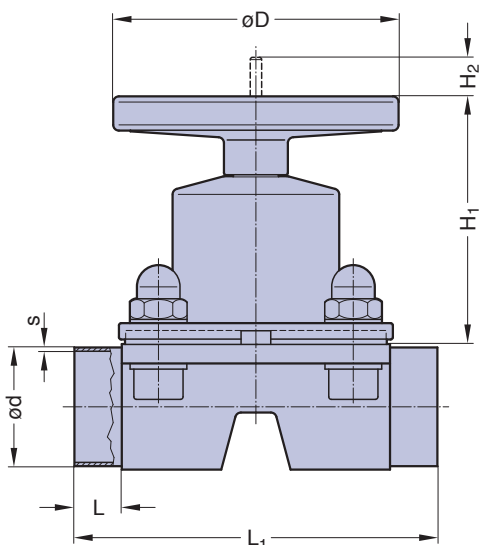

DN 65 - 100 (Drawing MA 80)

Valve type overview see page 26 and 27.
 Ordering key see page 62 and 63.

KMA 905

Manual Valve DN 15 - 50 mm (3/4" - 2 1/2")

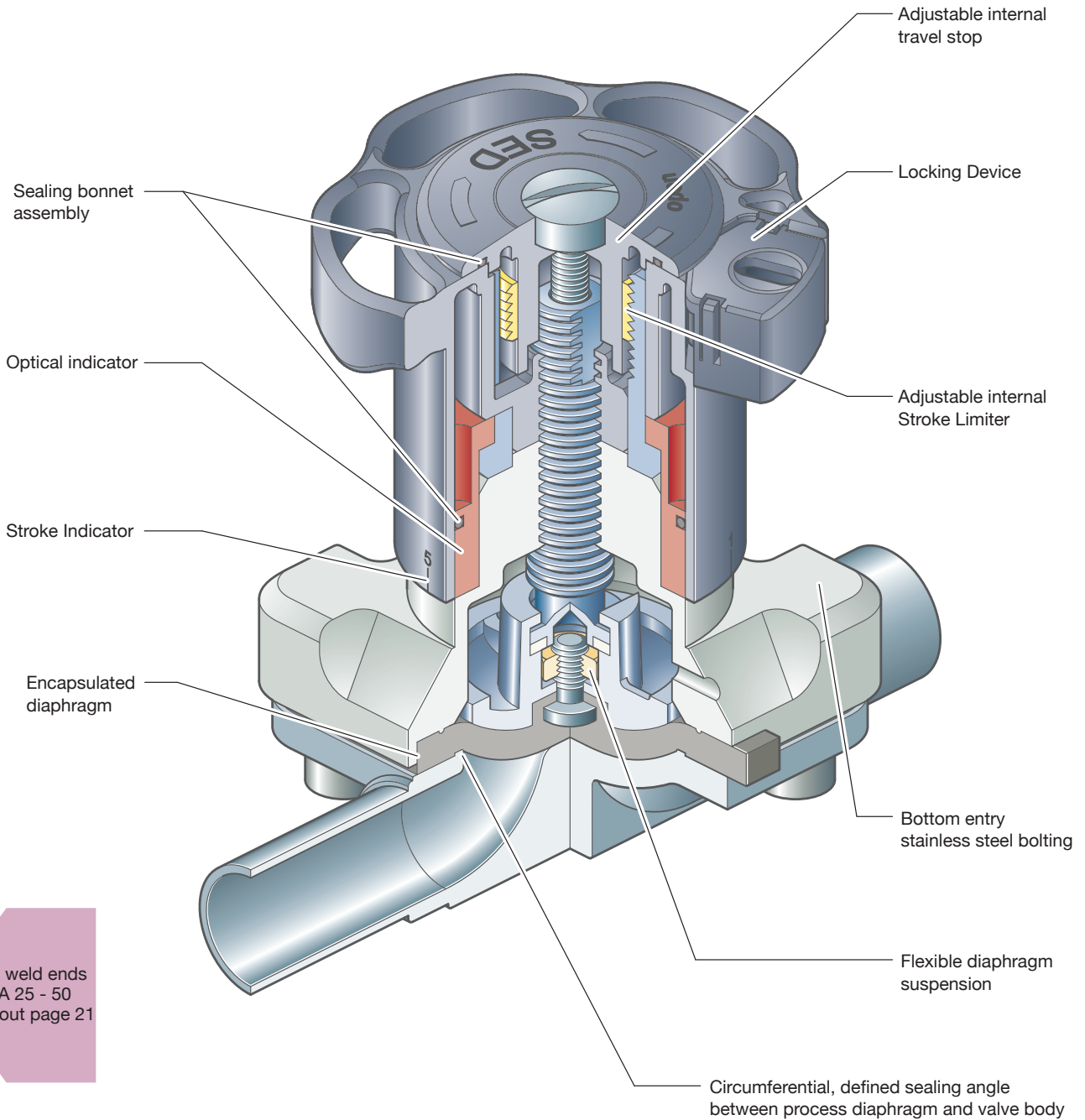

Butt weld ends
MA 25 - 50
Fold out page 21



Introduction Video
<http://www.sed-flowcontrol.com/en/service/movies>

KMA 905

Manual Valve DN 15 - 50 mm (3/4" - 2 1/2")



S01



S11

Features

- Stainless steel bonnet and plastic hand wheel
- Rising hand wheel with optical indicator and stroke indicator
- Sealed bonnet
- Internal travel stop
- Locking device
- CDSA sealing concept, see page 32
- Flexible diaphragm suspension
- Encapsulated diaphragm

Optional

- Adjustable internal stroke limiter
- U-Lock for hand wheel
- Assembly of proximity switches
- Manual diaphragm Valve with plastic hand wheel is suitable for a limited number of cycles of autoclaving.

Technical Data

- Control function: Manually operated
 Max. working pressure: 10 bar (150 psi)
 Max. working temperature: 160°C (320°F) dependent on application
 Diaphragm material: EPDM or PTFE
 Valve body material: Forged 1.4435/ 316L ASME/BPE
 Investment cast 1.4435/ 316L
 Other Alloys
- End connection: Butt weld ends see fold out page 21
 Clamps and flanges see page 22 and 23
 Special ends
- Bonnets suitable for: Two-Way bodies
 Welded configurations
 T- bodies
 Multiport bodies
 Tank bottom bodies
- Flow rate: Kv in m³/h (Cv in GPM) see page 9
 Diaphragm size: MA see table
 Technical data also valid for multiport valve.

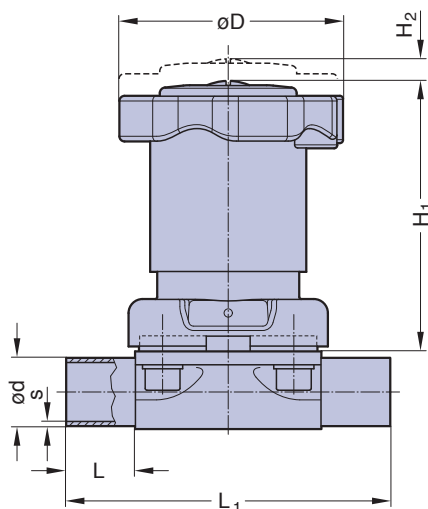

Butt weld ends
 MA 25 - 50
 Fold out page 21

DN (mm)	MA	Dimensions (mm)					Total weight ca. (kg)	
		L	L ₁	H ₁	H ₂	D	Investment cast	Forged
15-25	25	25	120	100	10	84	1,4	1,6
32-40	40	25	153	119	16	112	2,8	3,0
50	50	30	173	136	20	135	3,8	4,6

Valve type overview see page 26 and 27.
 Ordering key see page 62 and 63.

KMA 995

Manual Valve DN 65 - 100 mm (2 1/2" - 4")



DN 80

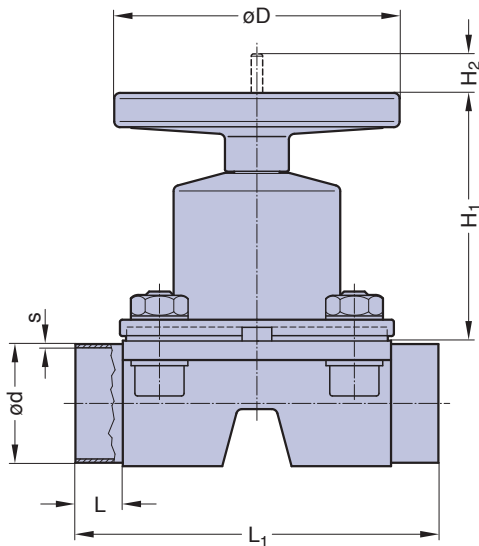

DN 65 - 100 (Drawing MA 80)

Features

- **Stainless steel bonnet and plastic hand wheel**
- Non rising hand wheel with optical indicator
- Flexible diaphragm suspension
- Encapsulated diaphragm
- CDSA sealing concept, see page 32

Optional

- Adjustable travel stop or stroke limiter
- Sealed bonnet
- Locking device

Technical Data

- Control function: Manually operated
 Max. working pressure: EPDM 10 bar (150 psi)
 PTFE 8 bar (115 psi)
 Max. working temperature: 160°C (320°F) dependent on application
 Diaphragm material: EPDM or PTFE
 Valve body material: Forged 1.4435/ 316L ASME/BPE
 Investment cast 1.4435/ 316L
 Other Alloys
- End connection: Butt weld ends see fold out page 21
 Clamps and flanges see page 22 and 23
 Special ends
- Bonnets suitable for: Two-Way bodies
 Welded configurations
 T- bodies
 Multiport bodies
 Tank bottom bodies
- Flow rate: Kv in m³/h (Cv in GPM) see page 9
 Diaphragm size: MA see table
 Technical data also valid for multiport valve.

DN (mm)	MA	Dimensions (mm)					Total weight ca. (kg)	
		L	L ₁	H ₁	H ₂	D	Investment cast	Forged
65	80	30	216	180	38	198	10,0	13,0
80	80	30	254	180	38	198	10,0	13,0
100	100	30	305	220	50	252	19,0	17,0

Butt weld ends
 MA 25 - 100
 Fold out page 21

Valve type overview see page 26 and 27.
 Ordering key see page 62 and 63.

KMD 985

Manual Valve DN 65 - 100 mm (2 1/2" - 4")



DN 100

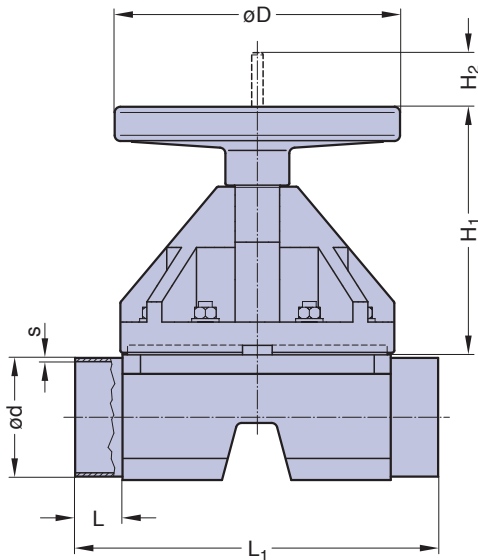

DN 65 - 100 (Drawing MA 100)

Features

- Plastic bonnet and plastic hand wheel
- Non rising hand wheel with optical indicator
- Flexible diaphragm suspension
- Encapsulated diaphragm
- CDSA sealing concept, see page 32

Optional

- Adjustable travel stop or stroke limiter on top
- Sealed bonnet
- Locking device

Technical Data

- Control function: Manually operated
 Max. working pressure: EPDM 10 bar (150 psi)
 PTFE 8 bar (115 psi)
 Max. working temperature: S-Version 80°C (176°F)
 dependent on application
 Diaphragm material: EPDM or PTFE
 Valve body material: Forged 1.4435/ 316L ASME/BPE
 Investment cast 1.4435/ 316L
 Other Alloys
 End connection: Butt weld ends see fold out page 21
 Clamps and flanges see page 22 and 23
 Special ends
 Suitable for:
 Bonnets up to DN 50: Two-Way bodies
 Bonnets bigger DN 50: Two-Way bodies
 Welded configurations
 T- bodies
 Multiport bodies
 Tank bottom bodies
 Flow rate: Kv in m³/h (Cv in GPM) see page 9
 Diaphragm size: MA see table

DN (mm)	MA	Dimensions (mm)					Total weight ca. (kg)	
		L	L ₁	H ₁	H ₂	D	Investment cast	Forged
65	80	30	216	180	38	198	7,0	9,0
80	80	30	254	180	38	198	7,0	9,0
100	100	30	305	220	50	252	14,0	12,0

Valve type overview see page 26 and 27.
 Ordering key see page 62 and 63.

Butt weld ends
 MA 25 - 100
 Fold out page 21

KMD 982

Manual Valve DN 15 - 50 mm (3/4" - 2 1/2")

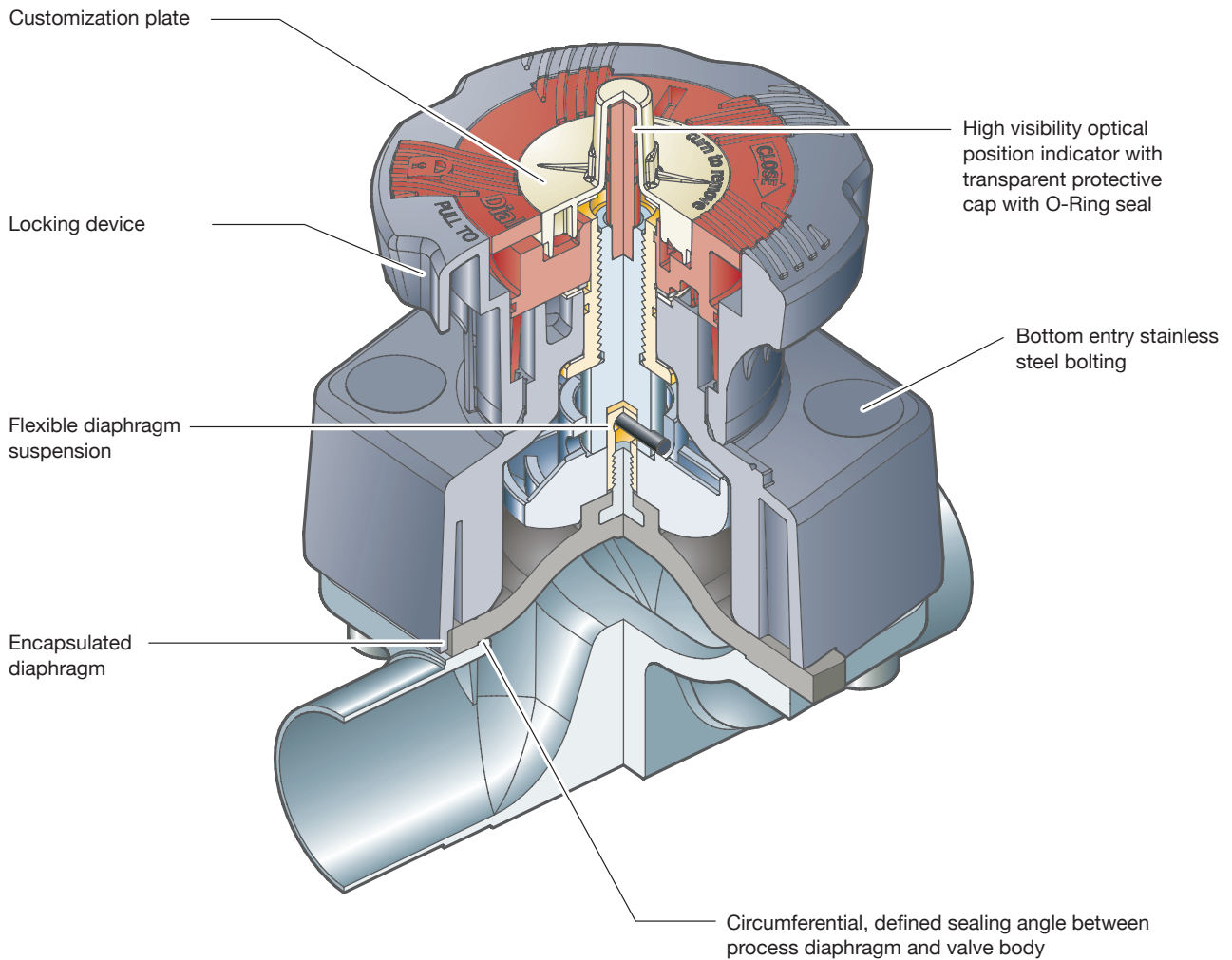

Butt weld ends
MA 25 - 50
Fold out page 21

KMD 982

Manual Valve DN 15 - 50 mm (3/4" - 2 1/2")



Features

- Plastic bonnet and plastic hand wheel
 - Non rising hand wheel with optical indicator
 - Flexible diaphragm suspension
 - Encapsulated diaphragm
 - CDSA sealing concept, see page 32
 - Locking device
- The system can be engaged by simply lifting the handwheel once the required position has been reached. To release the operating mechanism, simply return the handwheel to its previous position by pushing it downwards. When the system is in the locked position, u-lock can be installed to protect the plant against unwanted interference.

Optional

- Adjustable stroke limiter on top

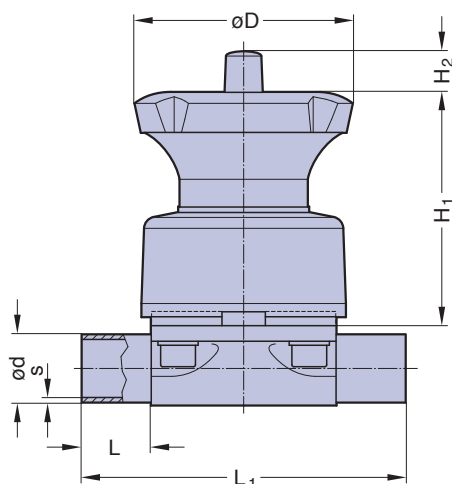

Technical Data

- Control function: Manually operated
 Max. working pressure: 10 bar (150 psi)
 Max. working temperature: 80°C (176°F)
 dependent on application
- Diaphragm material: EPDM or PTFE
 Valve body material: Forged 1.4435/ 316L ASME/BPE
 Investment cast 1.4435/ 316L
 Other Alloys
- End connection: Butt weld ends see fold out page 21
 Clamps and flanges see page 22 and 23
 Special ends
- Suitable for: Two-Way bodies,
 otherwise depending on design
- Flow rate: Kv in m³/h (Cv in GPM) see page 9
 Diaphragm size: MA see table

DN (mm)	MA	Dimensions (mm)					Total weight ca. (kg)	
		L	L ₁	H ₁	H ₂	D	Investment cast	Forged
15-25	25	25	120	85	15	154	0,87	0,96
32-40	40	25	153	102	24	194	1,59	1,83
50	50	30	173	117	24	224	2,30	3,40

Butt weld ends
 MA 25 - 50
 Fold out page 21

Valve type overview see page 26 and 27.
 Ordering key see page 62 and 63.

Steripur 207

Pneumatically Operated Valve DN 4 - 15 mm (1/4" - 1/2")

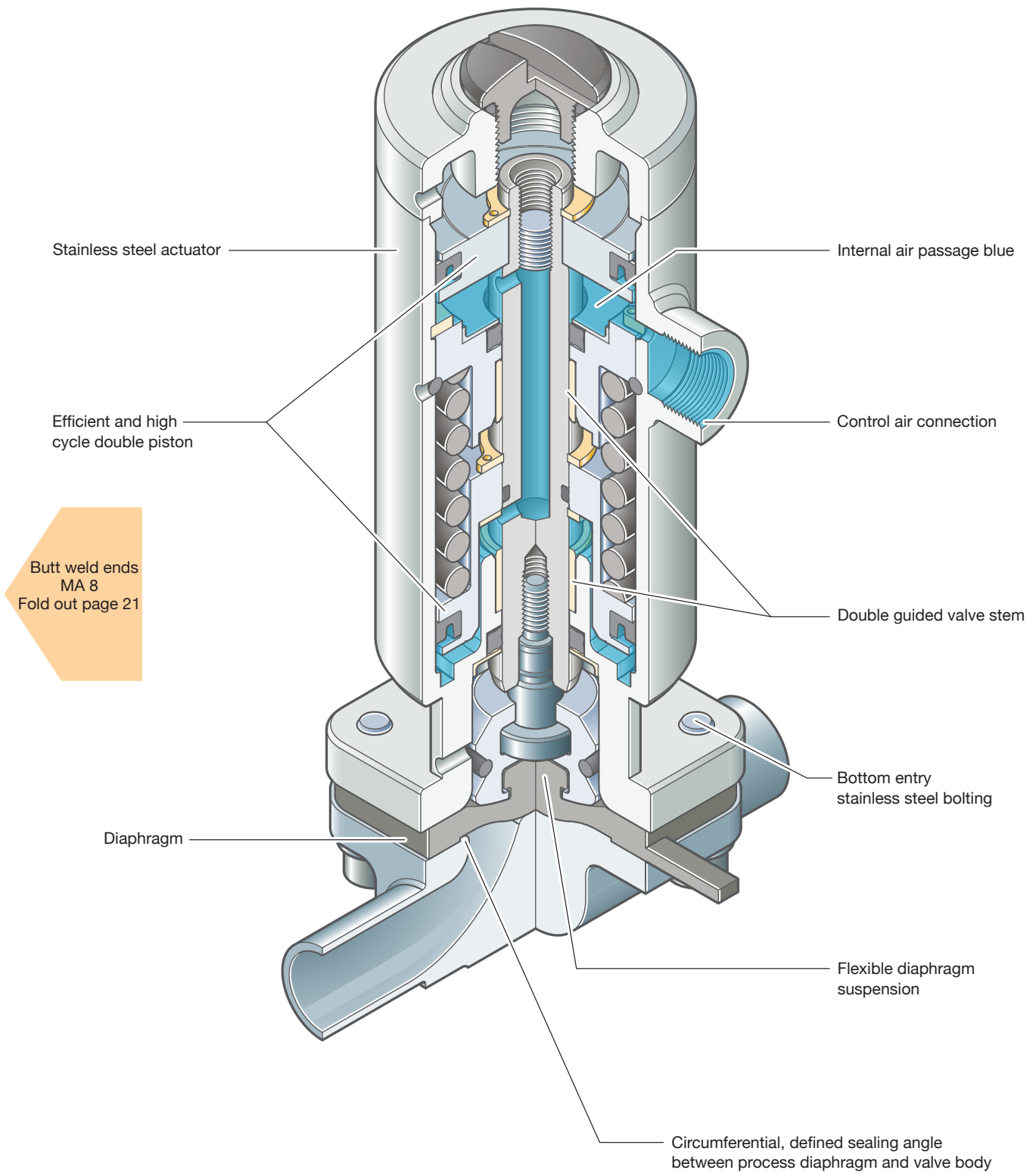

Sectional drawing shows Steripur 207.30

Steripur 207

Pneumatically Operated Valve DN 4 - 15 mm (1/4" - 1/2")



207.30 Cf. 4



207.25 Cf. 4, 5 & 6

This valve is available in two different designs.

The type 207.30 is available in the control function fail safe close and performs at a higher working pressure for standard application. The type 207.25 in control function fail safe close is mainly designed for filling applications or all other where the working pressure is lower. One advantages of this design are a longer diaphragm life time because there spring force is less. Other advantages of this design are a very high cycle life and a smaller overall dimensional height. Type 207.25 is also available in control functions fail safe open and double acting for standard working pressures.

Features

- High cycle stainless steel piston actuator
- Type 207.30 with double piston
- Compact design, the outside diameter of the actuator is the same size as the bonnet flange connecting diaphragm and body
- Advantages in multiport bodies and manifold valve assemblies
- Low control air volume, high switching speed
- High repeatability
- Control air connection on the top, away from the process product line
- Direction of control air connection is mountable in 90° rotations
- CDSA sealing concept, see page 32
- Flexible diaphragm suspension
- Clean and polished exterior design ideal for sterile wash downs

Optional

- Available with a wide range of control equipment and accessories see page 108 to 115 for this options
- Autoclavable

Technical Data

Control function (Cf.):	Pneumatically operated
207.30:	Fail safe close (NC): Cf. 1 & 4
207.25:	Fail safe close (NC): Cf. 1 & 4
	Fail safe open (NO): Cf. 2 & 5
	Double acting (DA): Cf. 3 & 6

Direction

Control connection: At Cf. 4, 5 & 6 in flow direction, standard
At Cf. 1, 2 & 3, 90° to flow direction

Max. working pressure: Unidirectional (delta p = 100%)

207.30:	Cf: Fail safe close	EPDM diaphragm 8 bar (115 psi)	PTFE diaphragm 7 bar (100 psi)
207.25:	Cf: Fail safe close	EPDM diaphragm 4,5 bar (65 psi)	PTFE diaphragm 3,5 bar (60 psi)
	Cf: Fail safe open and double acting	EPDM diaphragm 8 bar (115 psi)	PTFE diaphragm 7 bar (100 psi)

Higher working pressure may be achieved with different actuator. Please consult a SED factory representative for working pressure above the indicated maximum.

Max. working temperature: 160°C (320°F) dependent on application
Control pressure:

207.30:	Cf. 1 & 4	4 - 7 bar (60 - 100 psi)
207.25:	Cf. 1 & 4	5,5 - 7 bar (80 - 100 psi)
	Cf. 2, 3, 5 & 6	5,5 - 7 bar (80 - 100 psi)

Diaphragm material: EPDM or PTFE

Valve body material: Forged 1.4435/ 316 L ASME/BPE
Investment cast 1.4435/ 316 L
Other alloys

End connection: Butt weld ends see fold out page 21
Clamps and flanges see page 22 and 23
Special ends

Actuators suitable for: Two-Way bodies, Welded configurations, T-bodies, Multiport bodies, Tank bottom bodies

Flow rate: Kv in m³/h (Cv in GPM) see page 9

Diaphragm size: MA 8

Weight: 207.30: ca. 0,45 kg
207.25: ca. 0,44 kg

Technical data also valid for multiport valve.

Butt weld ends
MA 8
Fold out page 21

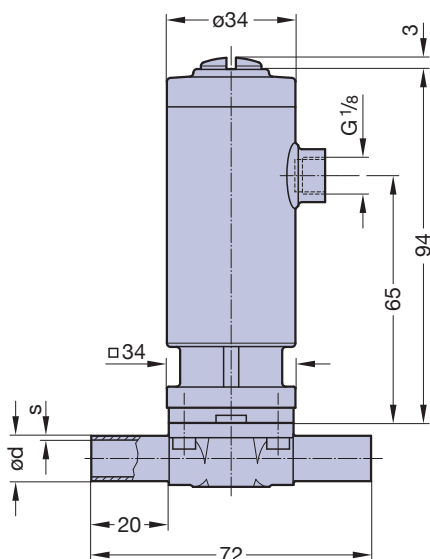
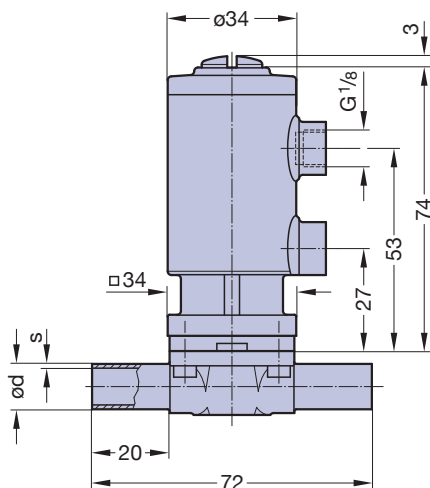

Valve type overview see page 26 and 27.
Ordering key see page 62 and 63.

KMA 190

Pneumatically Operated Valve DN 4 - 15 mm (1/4" - 1/2")



Cf. 1, 2 & 3

Features

- Efficient plastic piston actuator with stainless steel distance piece
- Direction of control air connection is mountable in 90° rotations
- CDSA sealing concept, see page 32
- Flexible diaphragm suspension
- Optical indicator

Optional

- Available with a wide range of control equipment and accessories see page 108 to 115, also for retrofitting



Cf. 4, 5 & 6

Butt weld ends
MA 8
Fold out page 21

Technical Data

- Control function (Cf.): Pneumatically operated
 Fail safe close (NC): Cf. 1 & 4
 Fail safe open (NO): Cf. 2 & 5
 Double acting (DA): Cf. 3 & 6
- Direction
 Control connection: At Cf. 1, 2 & 3, 90° to flow direction, standard
 At Cf. 4, 5 & 6 in flow direction
- Max. working pressure: Unidirectional (delta p = 100%)
 EPDM diaphragm 8 bar (115 psi)
 PTFE diaphragm 7 bar (100 psi)

Higher working pressure may be achieved with different actuator. Please consult a SED factory representative for working pressure above the indicated maximum.

- Max. working temperature: 160°C (320°F) dependent on application
 Control pressure: Cf. 1 & 4 4 - 7 bar (60 - 100 psi)
 Cf. 2, 3, 5 & 6 3,5 - 4,5 bar (50 - 65 psi)

- Diaphragm material: EPDM or PTFE
 Valve body material: Forged 1.4435/ 316 L ASME/BPE
 Investment cast 1.4435/ 316 L
 Other alloys

- End connection: Butt weld ends see fold out page 21
 Clamps and flanges see page 22 and 23
 Special ends

- Actuators suitable for: Two-Way bodies
 Welded configurations
 T-bodies
 Multiport bodies
 Tank bottom bodies

Flow rate: Kv in m³/h (Cv in GPM) see page 9

Diaphragm size: MA 8

Weight: ca. 0,5 kg

Technical data also valid for multiport valve.

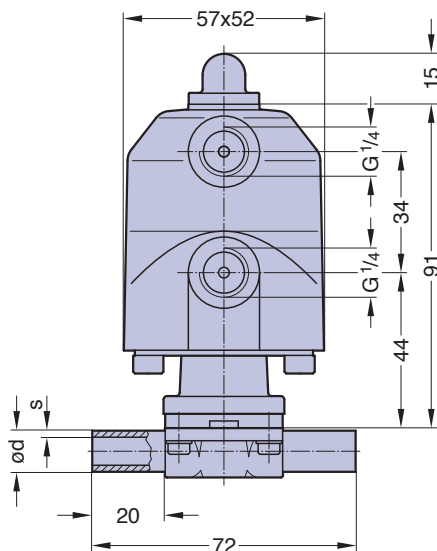

Valve type overview see page 26 and 27.
 Ordering key see page 62 and 63.

Steripur 307

Pneumatically Operated Valve DN 8 - 20 mm (3/8" - 3/4")



Cf. 4

Features

- High cycle stainless steel piston actuator
- Compact design, the outside diameter of the actuator is the same size as the bonnet flange
- Advantages in multiport bodies and manifold valve assemblies
- Control air connection in flow direction
- CDSA sealing concept, see page 32
- Flexible diaphragm suspension
- Encapsulated diaphragm
- Clean and polished exterior design ideal for sterile wash downs

Optional

- Available with a wide range of control equipment and accessories see page 108 to 115, also for retrofitting
- Control air connection 90° to flow direction
- Autoclavable

Technical Data

Control function (Cf.): Pneumatically operated
 Fail safe close (NC): Cf. 1 & 4
 Fail safe open (NO): Cf. 2 & 5
 Double acting (DA): Cf. 3 & 6

Direction

Control connection: At Cf. 4, 5 & 6 in flow direction, standard
 At Cf. 1, 2 & 3, 90° to flow direction

Max. working pressure: Unidirectional (delta p = 100%)
 EPDM diaphragm 8 bar (115 psi)
 PTFE diaphragm 7 bar (100 psi)

Higher working pressure may be achieved with different actuator. Please consult a SED factory representative for working pressure above the indicated maximum.

Max. working temperature: 160°C (320°F) dependent on application
 Control pressure: Cf. 1 & 4 4,2 - 7 bar (60 - 100 psi)
 Cf. 2, 3, 5 & 6 4 - 5 bar (60 - 72 psi)

Diaphragm material: EPDM or PTFE
 Valve body material: Forged 1.4435/ 316 L ASME/BPE
 Investment cast 1.4435/ 316 L
 Other alloys

End connection: Butt weld ends see fold out page 21
 Clamps and flanges see page 22 and 23
 Special ends

Actuators suitable for: Two-Way bodies
 Welded configurations
 T-bodies
 Multiport bodies
 Tank bottom bodies

Flow rate: Kv in m³/h (Cv in GPM) see page 9

Diaphragm size: MA 10

Weight: ca. 1,0 kg

Technical data also valid for multiport valve.

Valve type overview see page 26 and 27.
 Ordering key see page 62 and 63.

Butt weld ends
 MA 10
 Fold out page 21

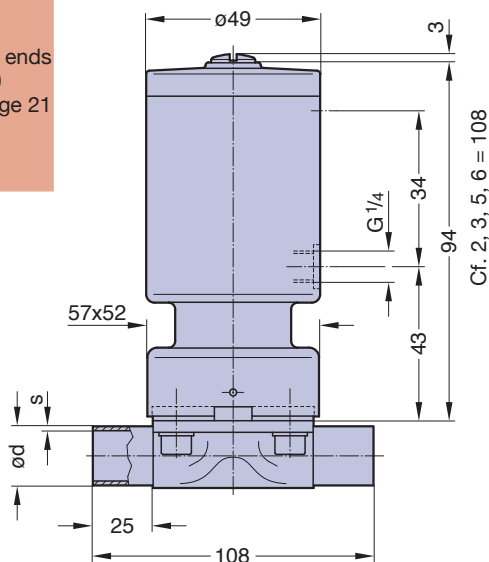

KMA 195

Pneumatically Operated Valve DN 8 - 20 mm (3/8" - 3/4")



Cf. 1, 2 & 3



Cf. 4 & 5

Butt weld ends
MA 10
Fold out page 21

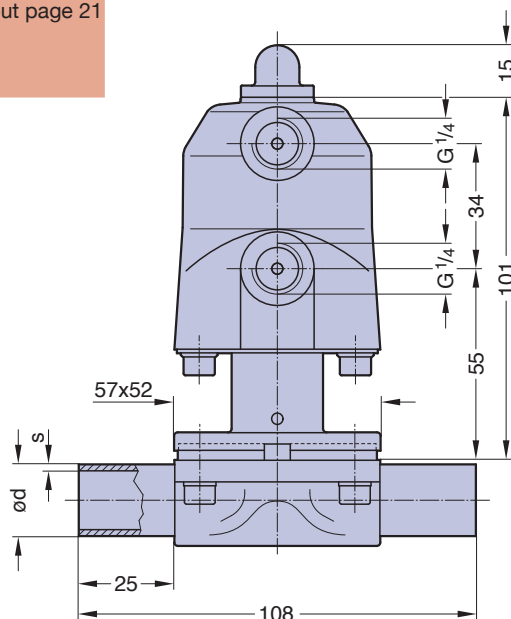

Features

- Efficient plastic piston actuator with stainless steel distance piece
- Control air connection 90° to flow direction
- Flexible diaphragm suspension
- Encapsulated diaphragm
- Optical indicator
- Compact design, the outside diameter of the actuator is the same size as the bonnet flange
- CDSA sealing concept, see page 32

Optional

- Available with a wide range of control equipment and accessories see page 108 to 115, also for retrofitting
- Control air connection in flow direction

Technical Data

- Control function (Cf.): Pneumatically operated
 Fail safe close (NC): Cf. 1 & 4
 Fail safe open (NO): Cf. 2 & 5
 Double acting (DA): Cf. 3
- Direction
 Control connection: At Cf. 1, 2 & 3, 90° to flow direction, standard
 Max. working pressure: Unidirectional (delta p = 100%)
 EPDM diaphragm 8 bar (115 psi)
 PTFE diaphragm 7 bar (100 psi)

Higher working pressure may be achieved with different actuator. Please consult a SED factory representative for working pressure above the indicated maximum.

- Max. working temperature: 160°C (320°F) dependent on application
 Control pressure: Cf. 1 4,2 - 7 bar (60 - 100 psi)
 Cf. 2, 3 4 - 5 bar (60 - 72 psi)
- Diaphragm material: EPDM or PTFE
 Valve body material: Forged 1.4435/ 316 L ASME/BPE
 Investment cast 1.4435/ 316 L
 Other alloys
- End connection: Butt weld ends see fold out page 21
 Clamps and flanges see page 22 and 23
 Special ends
- Actuators suitable for: Two-Way bodies
 Welded configurations
 T-bodies
 Multiport bodies
 Tank bottom bodies
- Flow rate: Kv in m³/h (Cv in GPM) see page 9
 Diaphragm size: MA 10
 Weight: ca. 0,8 kg
 Technical data also valid for multiport valve.

Valve type overview see page 26 and 27.
 Ordering key see page 62 and 63.

KMD 188

Pneumatically Operated Valve DN 8 - 20 mm (3/8" - 3/4")



HS-Version, Cf. 1, 2 & 3



HS-Version, Cf. 4 & 5

Butt weld ends
MA 10
Fold out page 21

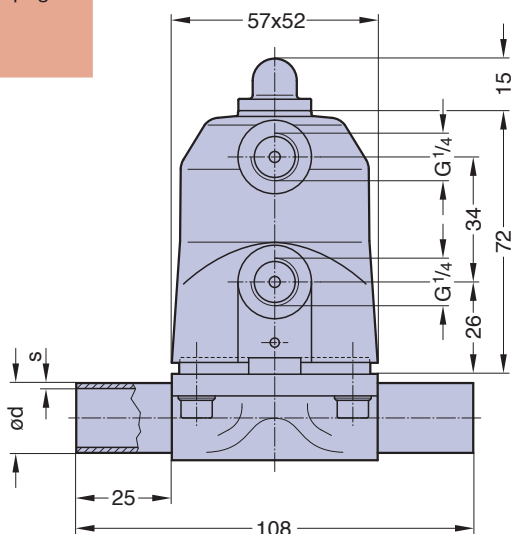

Features

- Efficient plastic piston actuator direct assembled with the valve body
- Control air connection 90° to flow direction for side by side or other installations saving space
- Compact design, the outside diameter of the actuator is the same size as the bonnet flange
- Actuator high resistance to heat transfer
- Smooth exterior design ideal for wash downs
- Encapsulated diaphragm
- Optical indicator
- CDSA sealing concept, see page 32

Optional

- Available with a wide range of control equipment and accessories see page 108 to 115, also for retrofitting
- Control air connection in flow direction

Technical Data

Control function (Cf.): Pneumatically operated
Fail safe close (NC): Cf. 1 & 4
Fail safe open (NO): Cf. 2 & 5
Double acting (DA): Cf. 3

Direction

Control connection: At Cf. 1, 2 & 3, 90° to flow direction, standard
At Cf. 4 & 5 in flow direction

Max. working pressure: Unidirectional (delta p = 100%)
EPDM diaphragm 8 bar (115 psi)
PTFE diaphragm 7 bar (100 psi)

Higher working pressure may be achieved with different actuator. Please consult a SED factory representative for working pressure above the indicated maximum.

Max. working temperature: PS-Version 80°C (176°F)
HS-Version 150°C (300°F)
dependent on Application

Control pressure: Cf. 1 & 4 4,2 - 7 bar (60 - 100 psi)
Cf. 2, 3 & 5 4 - 5 bar (60 - 72 psi)

Diaphragm material: EPDM or PTFE

Valve body material: Forged 1.4435/ 316 L ASME/BPE
Investment cast 1.4435/ 316 L
Other alloys

End connection: Butt weld ends see fold out page 21
Clamps and flanges see page 22 and 23
Special ends

Actuators suitable for: Two-Way bodies
Welded configurations

Flow rate: Kv in m³/h (Cv in GPM) see page 9

Diaphragm size: MA 10
Weight: ca. 0,6 kg

Valve type overview see page 26 and 27.
Ordering key see page 62 and 63.

Steripur 407

Pneumatically Operated Valve DN 15 - 100 mm (3/4" - 4")

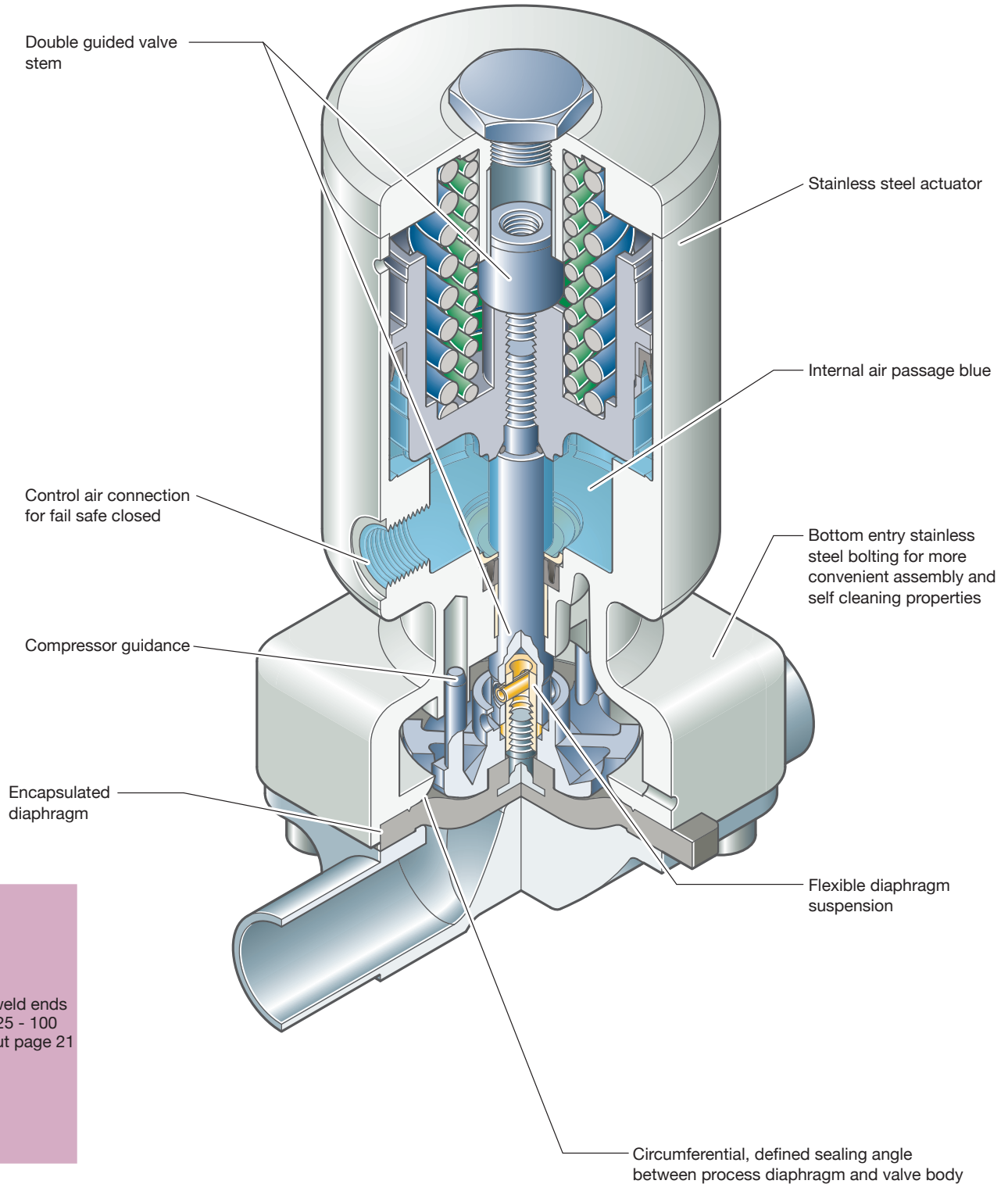

Butt weld ends
MA 25 - 100
Fold out page 21

Steripur 407

Pneumatically Operated Valve DN 15 - 100 mm (3/4" - 4")



DN 15 - 50 Cf. 4

Features

- High cycle stainless steel piston actuator
- Compact design, the outside diameter of the actuator is the same size as the bonnet flange
- Advantages in multiport bodies and manifold valve assemblies
- Control air connection in flow direction
- CDSA sealing concept, see page 32
- Flexible diaphragm suspension
- Encapsulated diaphragm
- Clean and polished exterior design ideal for sterile wash downs

Optional

- Available with a wide range of control equipment and accessories see page 108 to 115, also for retrofitting
- Control air connection 90° to flow direction
- Autoclavable

Technical Data

Control function (Cf.): Pneumatically operated
 Fail safe close (NC): Cf. 1 & 4
 Fail safe open (NO): Cf. 2 & 5
 Double acting (DA): Cf. 3 & 6

Direction

Control connection: At Cf. 4, 5 & 6, in flow direction, standard
 At Cf. 1, 2 & 3, 90° to flow direction

Max. working pressure: Unidirectional ($\Delta p = 100\%$)

Diaphragm	DN 15-50 (1/2"-2")	DN 65-80 (2,5"-3")	DN 100 (4")
EPDM	10 bar (150 psi)	7 bar (100 psi)	6 bar (87 psi)
PTFE	8 bar (115 psi)	6 bar (87 psi)	5 bar (72 psi)

Higher working pressure may be achieved with different actuator. Please consult a SED factory representative for working pressure above the indicated maximum.

Max. working temperature: 160°C (320°F) dependent on application

Control pressure:
 Cf. 1 & 4 DN 15-80 5 - 8 bar(72-115 psi)
 Cf. 1 & 4 DN 100 6 - 8 bar(87-115 psi)
 Cf. 2, 3, 5 & 6 DN 15-80 4,5-6 bar(65-87 psi)
 Cf. 2, 3, 5 & 6 DN 100 5,5-7 bar(80-100 psi)

Diaphragm material: EPDM or PTFE
 Valve body material: Forged 1.4435/ 316 L ASME/BPE
 Investment cast 1.4435/ 316 L
 Other alloys

End connection: Butt weld ends see fold out page 21
 Clamps and flanges see page 22 and 23
 Special ends

Actuators suitable for: Two-Way bodies
 Welded configurations
 T-bodies
 Multiport bodies
 Tank bottom bodies

Flow rate: Kv in m³/h (Cv in GPM) see page 9

Diaphragm size: MA see table below

Technical data also valid for multiport valve.

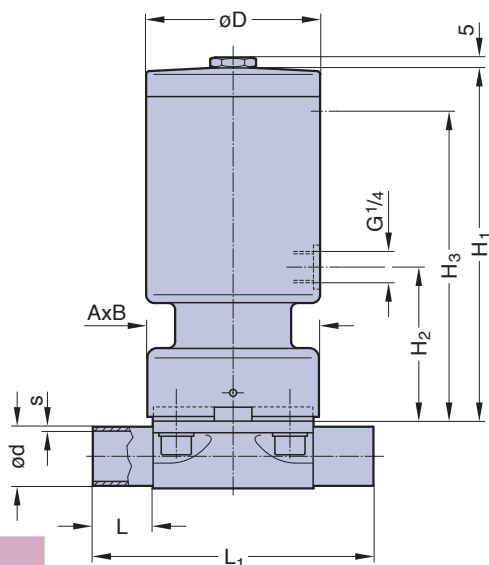

DN 15 - 50

Butt weld ends
 MA 25 - 100
 Fold out page 21

DN (mm)	MA	Dimensions (mm)							Total weight ca. (kg)	
		L	L ₁	A x B	H ₁	H ₂	H ₃	D	Investment cast	Forged
15-25	25	25	120	73x79	146*	66	133	75	2,6	2,7
32-40	40	25	153	96x105	180	75	160	105	6,0	7,0
50	50	30	173	110x130	216	77	180	105	9,0	10,0
65	80	30	216	170x190	309	135	285	179	23,0	26,0
80	80	30	254	170x190	309	135	285	179	23,0	26,0
100	100	30	305	ø238	318	143	295	179	33,0	1,0

* Cf. 2, 3, 5, 6 = 170

Valve type overview see page 26 and 27.
 Ordering key see page 62 and 63.

KMA 495

Pneumatically Operated Valve DN 15 - 100 mm (3/4" - 4")



Cf. 1

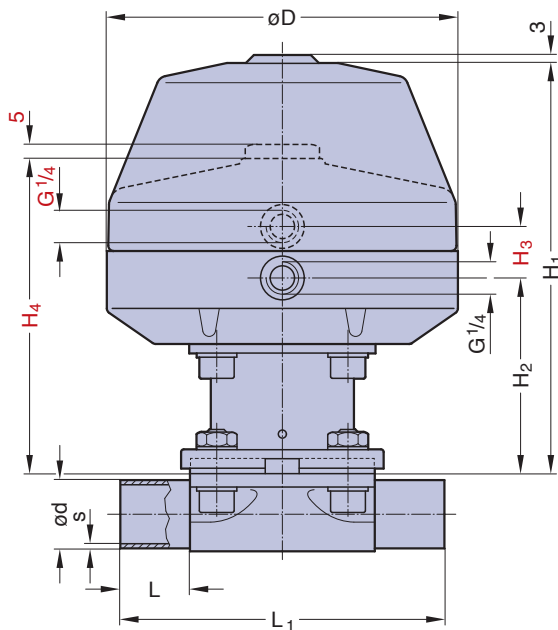

Butt weld ends
MA 25 - 100
Fold out page 21

Features

- Plastic diaphragm actuator with stainless steel distance piece
- Control air connection 90° to flow direction
- Flexible diaphragm suspension
- Encapsulated diaphragm
- CDSA sealing concept, see page 32

Optional

- Available with a wide range of control equipment and accessories see page 108 to 115, also for retrofitting

Technical Data

Control function (Cf.): Pneumatically operated
Fail safe close (NC): Cf. 1
Fail safe open (NO): Cf. 2
Double acting (DA): Cf. 3

Direction

Control connection: At Cf. 1, 2 & 3, 90° to flow direction, standard
Max. working pressure: Unidirectional ($\Delta p = 100\%$)

Diaphragm	DN 15-50 (1/2"-2")	DN 65-80 (2,5"-3")	DN 100 (4")
EPDM	10 bar (150 psi)	7 bar (100 psi)	6 bar (87 psi)
PTFE	8 bar (115 psi)	6 bar (87 psi)	5 bar (72 psi)

Higher working pressure may be achieved with different actuator. Please consult a SED factory representative for working pressure above the indicated maximum.

Max. working temperature: 160°C (320°F) dependent on application

Control pressure:

Cf. 1	DN 15-50	4,5 - 6 bar (65-87 psi)
Cf. 1	DN 65-80	4,5 - 7 bar (65-100 psi)
Cf. 1	DN 100	5,5 - 7 bar (80-100 psi)
Cf. 2 & 3	DN 15-80	4 - 5,5 bar (60-80 psi)
Cf. 2 & 3	DN 100	5 - 6,5 bar (72-93 psi)

Diaphragm material: EPDM or PTFE

Valve body material: Forged 1.4435/ 316 L ASME/BPE
Investment cast 1.4435/ 316 L
Other alloys

End connection: Butt weld ends see fold out page 21
Clamps and flanges see page 22 and 23
Special ends

Actuators suitable for: Two-Way bodies
Welded configurations
T-bodies
Multiport bodies
Tank bottom bodies

Flow rate: Kv in m³/h (Cv in GPM) see page 9

Diaphragm size: MA see table below

Technical data also valid for multiport valve.

DN (mm)	MA	Dimensions (mm)							Total weight ca. (kg)	
		L	L ₁	H ₁	H ₂	H ₃	H ₄	D	Investment cast	Forged
15-25	25	25	120	148	71	31	120	130	1,9	2,0
32-40	40	25	153	194	95	31	144	161	4,7	4,9
50	50	30	173	233	109	31	177	217	7,0	8,0
65	80	30	216	314	166	41	275	265	20,0	23,0
80	80	30	254	314	166	41	275	265	20,0	23,0
100	100	30	305	314	166	41	284	265	29,0	27,0

Note: H₃ and H₄ only for valves with Cf. 2 and Cf. 3 H₁ only for valve with Cf. 1

Valve type overview see page 26 and 27.
Ordering key see page 62 and 63.

KMA 395

Pneumatically Operated Valve DN 15 - 50 mm (3/4" - 2 1/2")



Cf. 4, 5 & 6

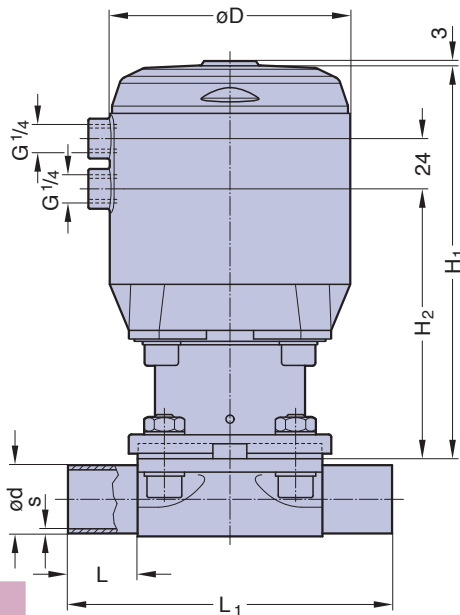

Butt weld ends
MA 25 - 50
Fold out page 21

Features

- Plastic piston actuator with stainless steel distance piece
- Compact design
- Control air connection in flow direction
- CDSA sealing concept, see page 32
- Flexible diaphragm suspension
- Encapsulated diaphragm

Optional

- Available with a wide range of control equipment and accessories see page 108 to 115, also for retrofitting
- Control air connection 90° to flow direction

Technical Data

Control function (Cf.): Pneumatically operated
 Fail safe close (NC): Cf. 1 & 4
 Fail safe open (NO): Cf. 2 & 5
 Double acting (DA): Cf. 3 & 6

Direction

Control connection: At Cf. 4, 5 & 6, in flow direction, standard
 At Cf. 1, 2 & 3, 90° to flow direction

Max. working pressure: Unidirectional (delta p = 100%)
 EPDM Diaphragm 10 bar (150 psi)
 PTFE Diaphragm 8 bar (115 psi)

Higher working pressure may be achieved with different actuator. Please consult a SED factory representative for working pressure above the indicated maximum.

Max. working temperature: 160°C (320°F) dependent on application

Control pressure: Cf. 1 & 4 4,5 - 7 bar (65 - 100 psi)
 Cf. 2, 3, 5 & 6 4 - 5 bar (60 - 72 psi)

Diaphragm material: EPDM or PTFE

Valve body material: Forged 1.4435/ 316 L ASME/BPE
 Investment cast 1.4435/ 316 L
 Other alloys

End connection: Butt weld ends see fold out page 21
 Clamps and flanges see page 22 and 23
 Special ends

Actuators suitable for: Two-Way bodies
 Welded configurations
 T-bodies
 Multiport bodies

Tank bottom bodies

Flow rate: Kv in m³/h (Cv in GPM) see page 9

Diaphragm size: MA see table below

Technical data also valid for multiport valve.

DN (mm)	MA	Dimensions (mm)					Total weight ca. (kg)	
		L	L ₁	H ₁	H ₂	D	Investment cast	Forged
15-25	25	25	120	160	107	95	1,9	2,0
32-40	40	25	153	190	129	115	3,9	4,2
50	50	30	173	236	171	144	7,0	8,0

Valve type overview see page 26 and 27.
 Ordering key see page 62 and 63.

KMD 385

Pneumatically Operated Valve DN 15 - 80 mm (3/4" - 3")



Cf. 1

Features

- Plastic diaphragm actuator direct assembled with the valve body
- Actuator high resistance to heat transfer
- Smooth exterior design ideal for wash downs
- Control air connection 90° to flow direction
- Flexible diaphragm suspension
- Encapsulated diaphragm
- CDSA sealing concept, see page 32

Optional

- Available with a wide range of control equipment and accessories see page 108 to 115, also for retrofitting

Technical Data

Control function (Cf.): Pneumatically operated
 Fail safe close (NC): Cf. 1
 Fail safe open (NO): Cf. 2
 Double acting (DA): Cf. 3

Direction

Control connection: At Cf. 1, 2 & 3, 90° to flow direction, standard

Max. working pressure: Unidirectional (delta p = 100%)

Diaphragm	DN 15-50 (1/2"-2")	DN 65-80 (2,5"-3")
EPDM	10 bar (150 psi)	7 bar (100 psi)
PTFE	8 bar (115 psi)	6 bar (87 psi)

Higher working pressure may be achieved with different actuator. Please consult a SED factory representative for working pressure above the indicated maximum.

Max. working temperature: S-Version 80°C (176°F)

Control pressure:
 Cf. 1 DN 15-50 4,5 - 6 bar (65-87 psi)
 Cf. 1 DN 65-80 4,5 - 7 bar (65-100 psi)
 Cf. 2 & 3 DN 15-80 4 - 5,5 bar (60-80 psi)

Diaphragm material: EPDM or PTFE
 Valve body material: Forged 1.4435/ 316 L ASME/BPE
 Investment cast 1.4435/ 316 L
 Other alloys

End connection: Butt weld ends see fold out page 21
 Clamps and flanges see page 22 and 23
 Special ends

Actuators suitable for: Two-Way bodies
 Welded configurations

Flow rate: Kv in m³/h (Cv in GPM) see page 9

Diaphragm size: MA see table below

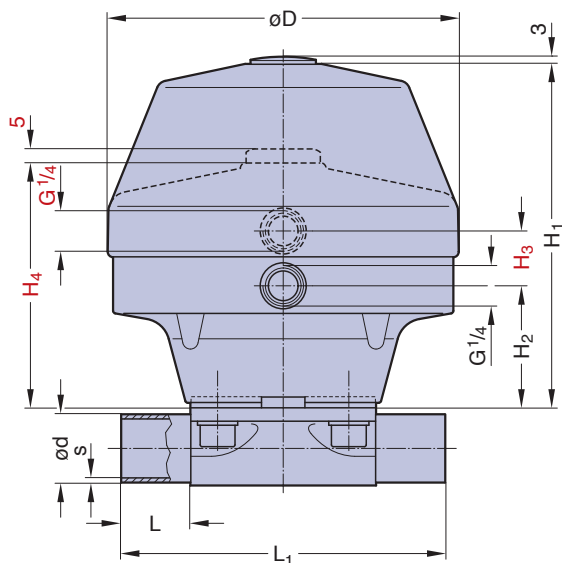

Butt weld ends
 MA 25 - 80
 Fold out page 21

DN (mm)	MA	Dimensions (mm)							Total weight ca. (kg)	
		L	L ₁	H ₁	H ₂	H ₃	H ₄	D	Investment cast	Forged
15-25	25	25	120	153	49	31	97	130	1,9	2,0
32-40	40	25	153	176	77	31	131	161	3,8	4,1
50	50	30	173	214	91	31	161	217	8,0	9,0
65	80	30	216	269	121	41	229	265	16,0	18,0
80	80	30	254	269	121	41	229	265	16,0	18,0

Note: H3 and H4 only for valves with Cf. 2 and Cf. 3 H1 only for valve with Cf. 1

Valve type overview see page 26 and 27.
 Ordering key see page 62 and 63.

KMD 402

Pneumatically Operated Valve DN 15 - 50 mm (3/4" - 2 1/2")



Cf. 4, 5 & 6

Features

- Plastic piston actuator
- Compact design
- Actuator high resistance to heat transfer
- Control air connection in flow direction
- CDSA sealing concept, see page 32
- Flexible diaphragm suspension
- Encapsulated diaphragm
- Smooth exterior design ideal for wash downs

Optional

- Available with a wide range of control equipment and accessories see page 108 to 115, also for retrofitting
- Control air connection 90° to flow direction

Technical Data

- Control function (Cf.): Pneumatically operated
 Fail safe close (NC): Cf. 1 & 4
 Fail safe open (NO): Cf. 2 & 5
 Double acting (DA): Cf. 3 & 6
- Direction
 Control connection: At Cf. 4, 5 & 6, in flow direction, standard
 At Cf. 1, 2 & 3, 90° to flow direction
- Max. working pressure: Unidirectional (delta p = 100%)
 EPDM Diaphragm 10 bar (150 psi)
 PTFE Diaphragm 8 bar (115 psi)
- Higher working pressure may be achieved with different actuator. Please consult a SED factory representative for working pressure above the indicated maximum.
- Max. working temperature: HS-Version 150°C (300°F)
 dependent on application
- Control pressure: Cf. 1 & 4 4,5 - 7 bar (65 - 100 psi)
 Cf. 2, 3, 5 & 6 4 - 5 bar (60 - 72 psi)
- Diaphragm material: EPDM or PTFE
- Valve body material: Forged 1.4435/ 316 L ASME/BPE
 Investment cast 1.4435/ 316 L
 Other alloys
- End connection: Butt weld ends see fold out page 21
 Clamps and flanges see page 22 and 23
 Special ends
- Actuators suitable for: Two-Way bodies
 Welded configurations
- Flow rate: Kv in m³/h (Cv in GPM) see page 9
- Diaphragm size: MA see table below

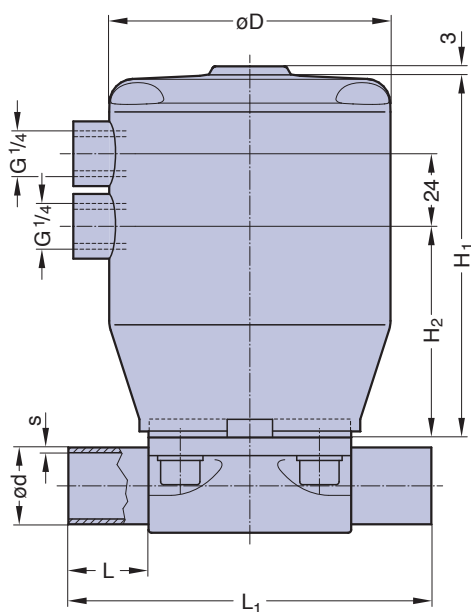

Cf. 1, 2 & 3

Butt weld ends
 MA 25 - 50
 Fold out page 21

DN (mm)	MA	Dimensions (mm)					Total weight ca. (kg)	
		L	L ₁	H ₁	H ₂	D	Investment cast	Forged
15-25	25	25	120	120	70	95	1,5	1,6
32-40	40	25	153	133	75	115	2,8	3,1
50	50	30	173	173	111	144	4,9	6,0

Valve type overview see page 26 and 27.
 Ordering key see page 62 and 63.

Steripur 392

Pneumatically Operated Valve DN 8 - 20 mm (3/8" - 3/4")

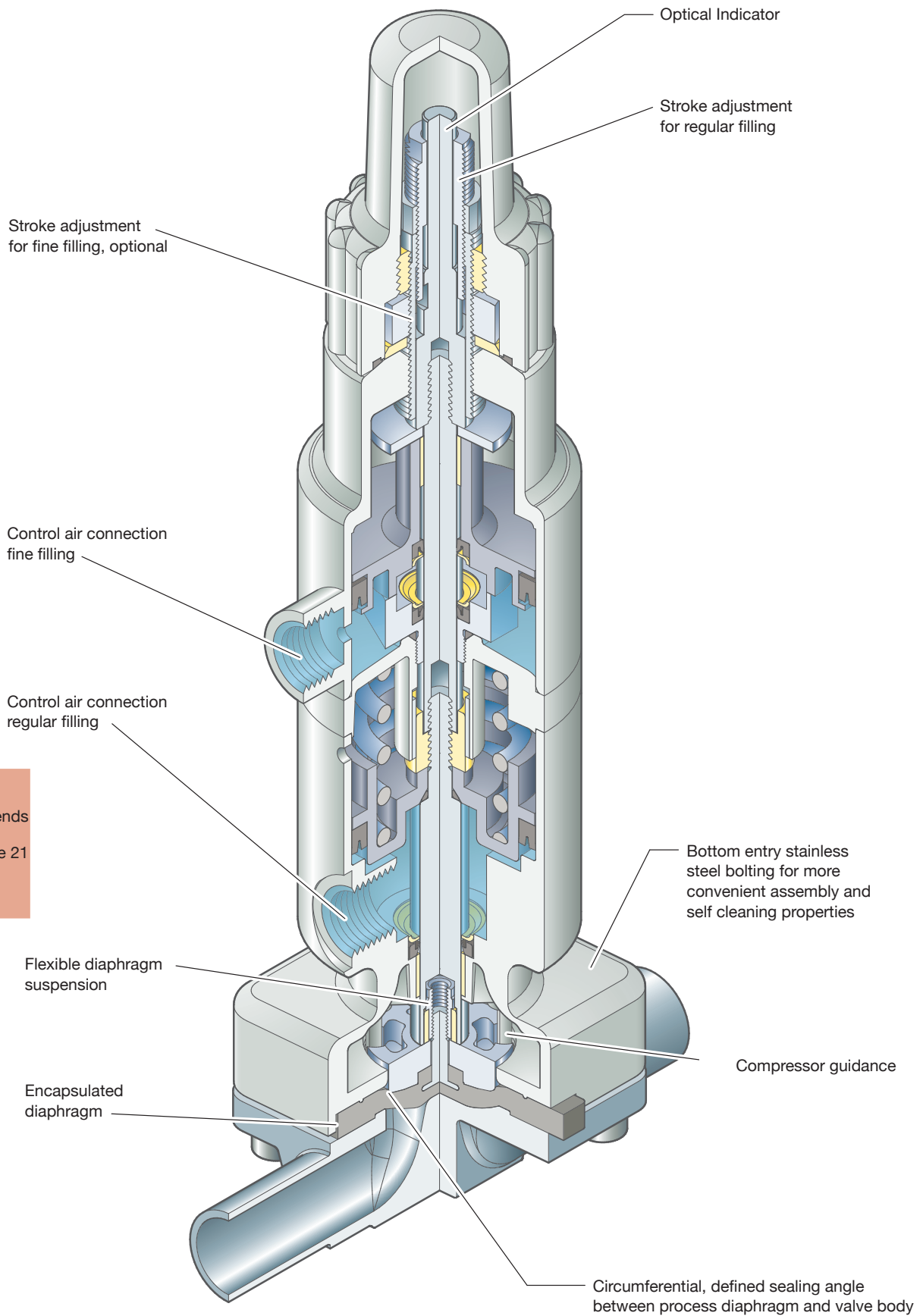

Steripur 392

Pneumatically Operated Valve DN 8 - 20 mm (3/8" - 3/4")



Features

- Two stage stainless steel actuator
- Second position adjustable with reduced flow for filling
- Compact design, the outside diameter of the actuator is the same size as the bonnet flange
- Advantages in multiport bodies and manifold valve assemblies
- Control air connection in flow direction
- CDSA sealing concept, see page 32
- Flexible diaphragm suspension
- Encapsulated diaphragm
- Clean and polished exterior design ideal for sterile wash downs
- Optical indicator

Optional

- Available with a wide range of control equipment and accessories see page 108 to 115, also for retrofitting
- Control air connection 90° to flow direction
- Autoclavable
- Indication of 3 positions with 024.50, see page 114 and 115
- Fine filling adjustment

Technical Data

Control function (Cf.): Pneumatically operated
Fail safe close (NC): Cf. 1 & 4

Direction

Control connection: At Cf. 4 in flow direction, standard
At Cf. 1, 90° to flow direction

Max. working pressure: Unidirectional (delta p = 100%)
EPDM Membrane 8 bar (115 psi)
PTFE Membrane 7 bar (100 psi)

Higher working pressure may be achieved with different actuator. Please consult a SED factory representative for working pressure above the indicated maximum.

Max. working temperature: 160°C (320°F) dependent on application

Control pressure: Cf. 1 & 4 4 - 7 bar (60 - 100 psi)

Diaphragm material: EPDM or PTFE

Valve body material: Forged 1.4435/ 316 L ASME/BPE
Investment cast 1.4435/ 316 L
Other alloys

End connection: Butt weld ends see fold out page 21
Clamps and flanges see page 22 and 23
Special ends

Actuators suitable for: Two-Way bodies
Welded configurations
T-bodies
Multiport bodies
Tank bottom bodies

Flow rate: Kv in m³/h (Cv in GPM) see page 9

Diaphragm size: MA 10

Weight: ca. 1,4 kg

Technical data also valid for multiport valve.

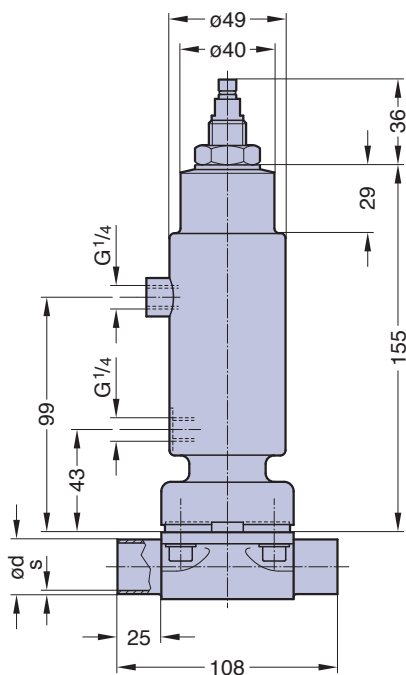

Butt weld ends
MA 10
Fold out page 21

Valve type overview see page 26 and 27.
Ordering key see page 62 and 63.

Steripur 592

Pneumatically Operated Valve DN 15 - 50 mm (3/4" - 2 1/2")



DN 50 Cf. 4

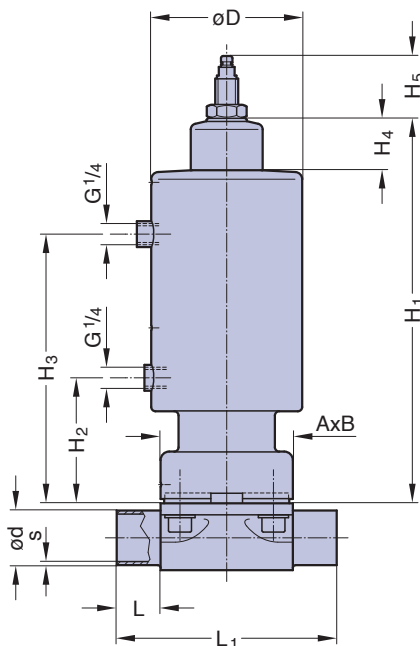

Butt weld ends
MA 25 - 50
Fold out page 21

Features

- Two stage stainless steel actuator
- Second position adjustable with reduced flow for filling
- Compact design, the outside diameter of the actuator is the same size as the bonnet flange
- Advantages in multiport bodies and manifold valve assemblies
- Control air connection in flow direction
- CDSA sealing concept, see page 32
- Flexible diaphragm suspension
- Encapsulated diaphragm
- Clean and polished exterior design ideal for sterile wash downs
- Optical indicator

Optional

- Available with a wide range of control equipment and accessories see page 108 to 115, also for retrofitting
- Control air connection 90° to flow direction
- Autoclavable
- Indication of 3 positions with 024.50, see page 114 and 115

Technical Data

Control function (Cf.): Pneumatically operated
Fail safe close (NC): Cf. 1 & 4

Direction

Control connection: At Cf. 4 in flow direction, standard
At Cf. 1, 90° to flow direction

Max. working pressure: Unidirectional ($\Delta p = 100\%$)

Diaphragm	DN 15 - 50 (1/2" - 2")
EPDM	10 bar (150 psi)
PTFE	8 bar (115 psi)

Higher working pressure may be achieved with different actuator. Please consult a SED factory representative for working pressure above the indicated maximum.

Max. working temperature: 160°C (320°F) dependent on application

Control pressure: Cf. 1 & 4 5 - 8 bar (72 - 115 psi)

Diaphragm material: EPDM or PTFE

Valve body material: Forged 1.4435/ 316 L ASME/BPE
Investment cast 1.4435/ 316 L
Other alloys

End connection: Butt weld ends see fold out page 21
Clamps and flanges see page 20 and 23
Special ends

Actuators suitable for: Two-Way bodies, Welded configurations,
T-bodies, Multiport bodies,
Tank bottom bodies

Flow rate: Kv in m³/h (Cv in GPM) see page 11

Diaphragm size: MA see table below

Technical data also valid for multiport valve.

DN (mm)	MA	Dimensions (mm)									Total weight ca. (kg)	
		L	L ₁	A x B	H ₁	H ₂	H ₃	H ₄	H ₅	D	Investment cast	Forged
15-25	25	25	120	73x79	220	66	150	-	35	75	2,8	2,9
32-40	40	25	153	96x105	250	75	185	28	40	105	7,0	7,0
50	50	30	173	110x130	294	77	221	28	47	105	9,0	10,0

Valve type overview see page 26 and 27.
Ordering key see page 62 and 63.

Twin diaphragm valve for filling

An Alternative solution to valve type 392 and 592

The **Twin Diaphragm Valve** combines two diaphragm valve bodies in one valve block assembled with two pneumatically operated diaphragm valve actuators.

The twin diaphragm valve has one inlet and one outlet tube end. The valve actuators can be operated independently from each other and optionally are different control components available to visualize and control the process.

The major application is the filling of liquids in cans, bottles or barrels. For fast filling both valves can be opened, and for the last part, to control the level and accuracy of filling, only one valve remains open. By using a stroke limiter, the flow rate of the valve which remains open to fill completely, can be adjusted. And helps avoiding foam over or sputtering of the medium.

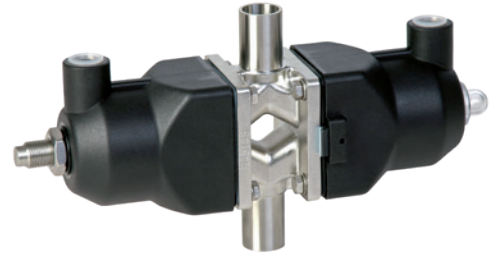

Valve type 188, Series KMD
Technical data see page 51



Valve type 402, Series KMD
Technical data see page 57

TECHNICAL FEATURES:

- Economical filling valve
- High cycle lifetime
- Control air connection in or 90° to flow direction
- CDSA sealing concept, easy to clean
- Compact solution
- Low weight
- Optimized internal design for maximum flow rate
- Less welding
- High filling volume
- Material 1.4435/316L solid block and investment cast
- Encapsulated Diaphragm
- Smooth exterior design ideal for wash down
- available with a wide range of Control equipment and accessories.
- All actuator series suitable

KMD 188

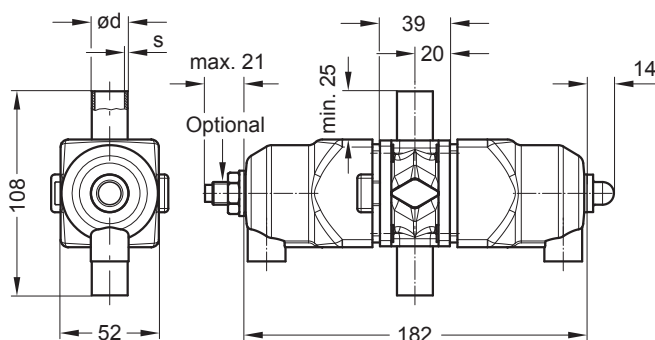

Solid block material all tube end standards available
Investment cast end connection code 45 (19,05x1,65) and code 42 (19x1,5) available

KMD 402

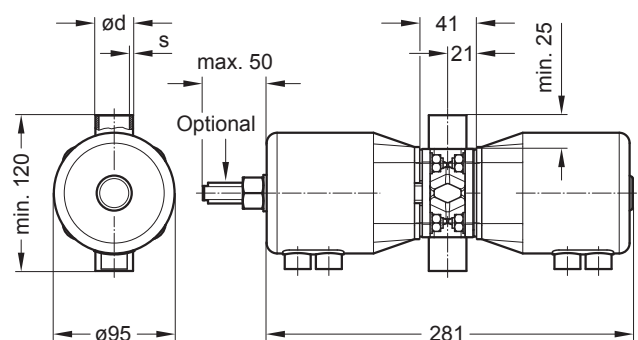

Solid block material all tube end standards available
Investment cast material all tube end standards MA25 available

Ordering key

1	2	3	4	5	6.1	6.2	7
Type	Size	Valve body material	Valve body end connection	Diaphragm material	Actuator control function	Actuator type	Surface roughness of the bodies in Ra
Pos.	Description	Code	Specification				
1	Type: See page 34 - 61	207, 307, 407 297, 397, 997 392, 592 190, 195, 395, 495 290, 295, 905, 995 188, 385, 402 289, 982, 985	Steripur Series, stainless steel actuator, pneumatic Steripur Series, stainless steel actuator, manual Steripur Series, two stage stainless steel actuator, pneumatic KMA Series, actuator with stainless steel adaptation, pneumatic KMA Series, actuator with stainless steel adaptation, manual KMD Series, plastic actuator direct mounted, pneumatic KMD Series, plastic actuator direct mounted, manual				
2	Size: See page: 21	04 - 100	DN 4, 6, 8, 10, 15, 20, 25, 32, 40, 50, 65, 80, 100				
3	Valve body material: See page: 20	7 77 78 20	Stainless steel, investment cast 1.4435/S31603, ASME BPE Table MM-2.1-1 Stainless steel, forged 1.4435/S31603, ASME BPE Table MM-2.1-1 Stainless steel, forged 1.4435/S31603 Fe < 0,5% Hastelloy, C-22 2.4602				
4	Valve body end connections: (bolt letters most common versions) Valve body end connection for assembly: See page 21 - 23	39 40 41 42 45 49 94 95 97 98 640 642 645 649 545 842 442 342 242	Butt weld end acc. DIN Butt weld end acc. EN ISO 1127 (DIN 11866 Series B) Butt weld end acc. DIN 11850 Series 1 Butt weld end acc. DIN 11850 Series 2 (DIN 11866 Series A) Butt weld end acc. ASME BPE MFS length (DIN 11866 Series C) Butt weld end acc. SMS 3008 Butt weld end acc. BS 4825 R1 Butt weld end acc. to ASME BPE Table DT-4.1-1 Tangent Length Butt weld end acc. JIS G 3447 Butt weld end acc. JIS G 3459 First digit stands for the end connection and last two digits for the tube standard Clamp ISO 1127, for tube EN ISO 1127, face to face DIN EN 558-1, Series 7 Clamp DIN 32676, for tube DIN 11850, face to face DIN EN 558-1, Series 7 Clamp ASME BPE, for tube ASME BPE, face to face DIN EN 558-1, Series 7 Clamp SMS 3017, for tube SMS 3008, face to face DIN EN 558-1, Series 7 Clamp ASME BPE, for tube ASME BPE, face to face ASME BPE Table DT-4.4.1-1 Aseptic Union DIN 11851, for tube DIN 11850 series 2 double-sided threaded spigot Aseptic Union DIN 11864-1-A, for tube DIN 11850 series 2 double-sided threaded spigot Aseptic flange DIN 11864-2-A, for tube DIN 11850 series 2, double-sided grooved Aseptic clamp DIN 11864-3-A, for tube DIN 11850 series 2, double-sided grooved				
5	Diaphragm material: (Other diaphragm materials on request) See page 14 - 19	28 20 30 51 44	EPDM, FDA / USP compliant MA 8 -100, preferred for SIP applications EPDM, FDA / USP compliant MA 8 -100, preferred for SIP applications PTFE(TFM) / EPDM one-piece, FDA / USP compliant, MA 25, 40, 50 PTFE(TFM) / EPDM one-piece, FDA / USP compliant, MA 8, MA 10 PTFE(TFM) / EPDM two-piece, FDA / USP compliant, MA 25 to MA 100				
6.1	Actuator control function (Cf.) and orientation air inlet connection: See page 34 - 61	1 2 3 4 5 6	Manually operated Normally closed (NC), orientation 90° to flow direction Normally open (NO), orientation 90° to flow direction Double-acting (DA), orientation 90° to flow direction Normally closed (NC), orientation in flow direction Normally open (NO), orientation in flow direction Double-acting (DA), orientation in flow direction				
6.2	Actuator type: See page 34 - 61	25 30 45 70 100 170 T AS S PS HS S01 S02 S03 S11 S12 S13	Steripur, actuator size 25 Steripur, actuator size 30 Steripur, actuator size 45 Steripur, actuator size 70 Steripur, actuator size 100 Steripur, actuator size 170 Steripur, manually operated KMA KMD, Type 289, 385, 402, 982, 985 max. 80°C KMD, Type 188 max 80°C KMD for steam sterilizing up to max. 150°C KMA, manually operated, incl. seal adjuster and locking device, Bonnet assembly bottom entry bolting KMA, manually operated, incl. seal adjuster, locking device and stroke limiter, Bonnet assembly bottom entry bolting KMA, manually operated, incl. seal adjuster, Bonnet assembly bottom entry bolting KMA, manually operated, incl. seal adjuster and locking device, Bonnet assembly through bolting KMA, manually operated, incl. seal adjuster, locking device and stroke limiter, Bonnet assembly through bolting KMA, manually operated, incl. seal adjuster, Bonnet assembly through bolting				

Ordering Example

7	Surface roughness of the bodies in Ra: (µm) Optional surface code SF 1-6 for spigot end (Pos. 4) code 45 or 95 only. See page 10 - 11	02	Internal mechanically polished Ra ≤ 0,8 µm
		03	Internal mechanically polished Ra ≤ 0,8 µm + Electropolished
		07	Internal mechanically polished Ra ≤ 0,6 µm
		08	Internal mechanically polished Ra ≤ 0,6 µm + Electropolished
		09	Internal mechanically polished Ra ≤ 0,4 µm
		10	Internal mechanically polished Ra ≤ 0,4 µm + Electropolished
		14	Inside mechanically polished Ra ≤ 0,25 µm
		16	Inside mechanically polished Ra ≤ 0,25 µm + Electropolished
		SF0	No Finish Requirement
		SF1	ASME BPE Table SF-2.4-1 Internal mechanically polished Ra ≤ 0,51 µm (20 µ-inch)
SF2	ASME BPE Table SF-2.4-1 Internal mechanically polished Ra ≤ 0,64 µm (25 µ-inch)		
SF3	ASME BPE Table SF-2.4-1 Internal mechanically polished Ra ≤ 0,76 µm (30 µ-inch)		
SF4	ASME BPE Table SF-2.4-1 Internal mechanically polished Ra ≤ 0,38 µm (15 µ-inch) + Electropolished		
SF5	ASME BPE Table SF-2.4-1 Internal mechanically polished Ra ≤ 0,51 µm (20 µ-inch) + Electropolished		
SF6	ASME BPE Table SF-2.4-1 Internal mechanically polished Ra ≤ 0,64 µm (25 µ-inch) + Electropolished		
8	S-Number:	S...	To specify customized design and all the details for multiport valves

Preferred standards bold. Visit our website (Configurator) to specify the right product for your application

Position: 1 2 3 4 5 6.1 6.2 7

Article Code: **495** . **25** . **77** . **42** . **18** . **1** **S** . **03**

Type: 495
KMA Series
actuator with stainless
steel adaption
pneumatic

Size: DN 25

Valve body material: Stainless steel,
forged
1.4435/316L ASME BPE

Valve body end connection: Butt weld tube end
DIN 11850 Series 2

Diaphragm material: EPDM
FDA / USP compliant

Actuator type: KMA for steam sterilizing
up to max. 160° C

Surface roughness of the bodies in Ra:
Internal mechanical polish
and electro polish
Ra ≤ 0,8 µm

Actuator control function and orientation air inlet connection:
Normally closed (NC)
orientation 90° to flow direction

System components and accessories see page 108 to 115

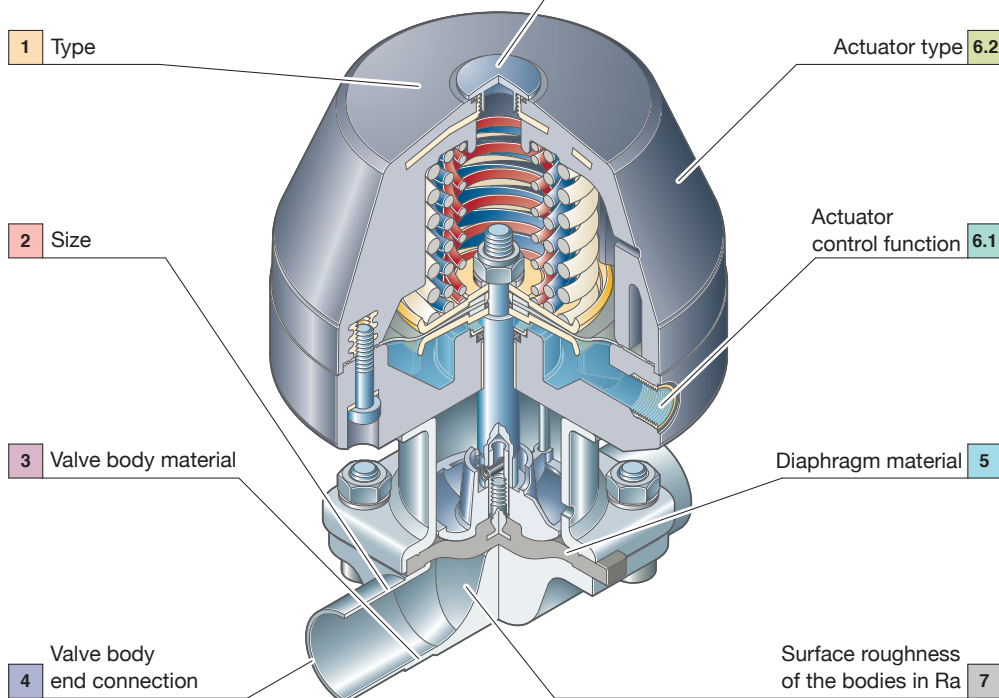

Table of Contents

1	Introduction	Page
	A Brief Overview	4
	The Company	5
	What does Quality mean at SED?	6
	General Information	
	Testing	7
	Qualification, Certification and Documentation	8
	Flow Rate and Valve Sizing	9
	Surface Finish	10, 11
2	Media Contacted Components	
	Diaphragms	14 - 19
	Valve Bodies (fold out page)	20
	Butt Weld Tube Ends (fold out page)	21
	Aseptic Connections	
	Clamps	22
	Aseptic Flanges and Aseptic Threads	23
3	Aseptic Diaphragm Valves	
	Overview Diaphragm Aseptic Valves	26, 27
	Why Aseptic Diaphragm Valve?	28
	Self Draining - Two-Way Valve	29
	Innovative Design	30 - 33
	Aseptic Diaphragm Valves	
	Aseptic Diaphragm Valve Manual	34 - 45
	Aseptic Diaphragm Valve Pneumatically Operated	46 - 61
	Ordering Key and Ordering Example	62, 63
4	Aseptic Diaphragm Valve Configurations	
	D-Rule	66
	Welded Valve Configurations	67 - 69
	Multiport Valves	
	Why Multiport Valves?	70
	Main line open, Loop Valves (e.g. T-Valve)	71 - 75
	All lines and valve ports able to close	76 - 81
	The way of customized multiport valve designs	82
	Specification Multiport Valves	83
	Tank Valves	84 - 87
	Process Solutions	
	Sterile Sampling Unit	88
	Purified Steam Sampling Unit	89
5	Angle Seat Valves	
	Description and Features	92
	Applications	93
	Ordering Key and Ordering Example	94, 95
	Technical Data	96
	2/2-Way Angle Seat Valves	97 - 103
	Valve Body Threaded Socket and Butt Weld End	104
	Valve Body Clamp Socket and Flange	105
6	System Components and Process Automation	
	Overview	108
	Manual Adjustment - Optical Indication	109
	Electrical Switch Boxes - Pilot Control	110
	Detailed Information	
	3/2 Way Plastic Pilot Valve Type 600 / 605	111
	3/2 Way Plastic Pilot Valve Type 602 / 603	112
	Control Head Switch 024.63. - 024.89.	113
	Contact-Free Limit Switch 024.50	114, 115
	Process Automation, Electropneumatic Positioners	116 - 118
	Overview Product Range	119
	Glossary	120, 121

D-Rule

D-Rule

The D-Rule is the dead leg as a relationship between the B and D dimension as described in ASME BPE.

This definition is a helpful guideline to describe the maximum allowable dead leg of combined components which are installed into aseptic process systems or process skids.

The dead leg is described with the B dimension in mm as absolute value or as a relationship of B/D.

Depending on the nominal diameters of the combinations and / or the positioning of the valve body, the relation can shift between 2:1 and 5:1. If the D-Rule is specified and the requirements can not be met with a welded valve configuration, the solution is manufacturing of the valve body as a multiport valve which is made from solid block material.

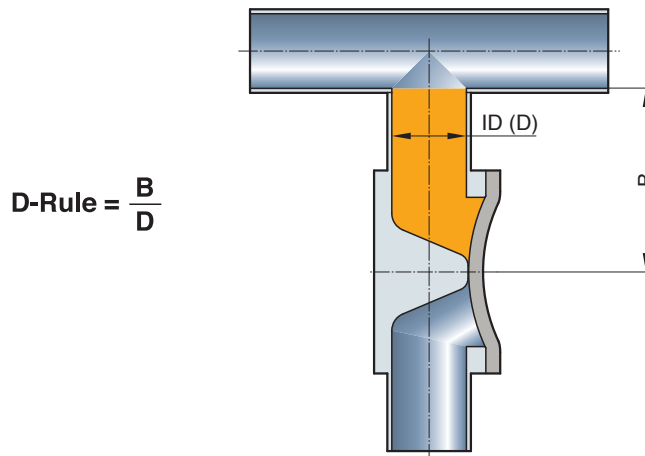

The B dimension and the relation of B/D are displayed in the dimensional data which can be provided on request.

Welded Valve Configurations

Welded valve configurations are designed to improve the process in aseptic production facilities by reducing the dead legs in accordance to cGMP. Welded valve configurations may be as simple as a valve by tube fabrication or as complex as multiple valve bodies of different sizes welded into a valve cluster. All welded end connections are available. The applications are endless and the challenge is to efficiently meet the process needs.

Strict quality control is followed for every welded valve configuration produced by SED. All weld seams that are accessible are polished according to the interior surface specification.

The completed welded valve configuration is visually inspected and 100% are pressure tested.

Advantages of a Welded Valve Configuration:

- Totally self draining
- Minimized dead legs
- Reduces surface contact and hold up volume of the medium
- Compact assembly
- Reduces number of welds
- Provides a ready-made assembly for field installation

During installation of welded valve configurations it is important to follow good piping practice to guarantee the valve assemblies drainability.

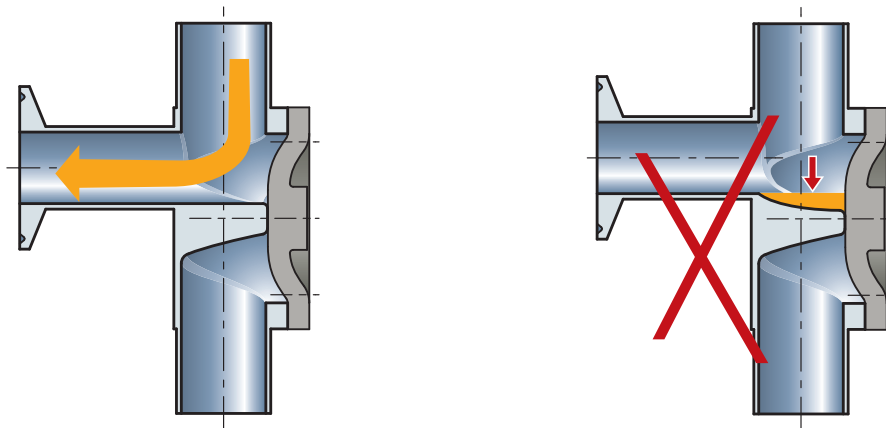

Welded Valve Configurations

The main valve orientation distinguishes between the two different principles: SL or SA

1) SL – L Pattern Configurations

The SL Fabrication is utilized in a vertical piping system to eliminate dead legs in point of use applications of high purity water systems or any other distribution systems. This valve design serves as a 90-degree elbow for the piping system or as a valve by valve configuration. In a valve by valve configuration the horizontal valve is orientated at the self-draining angle.

When the vertical main valve is opened it provides a sample untainted by bacterial growth or process contamination. The size range available is up to DN 100 (4") for both the main valve and L valve or tube port.

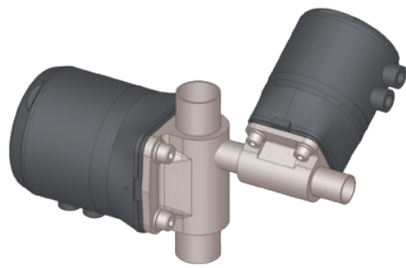

SL1.H

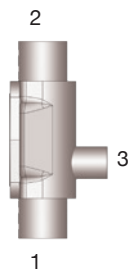

SL2.H

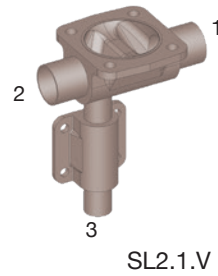
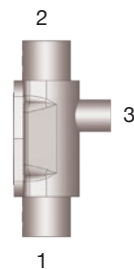

SL2.1.V

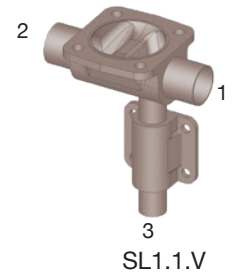

SL1.1.V

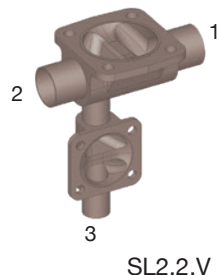

SL2.2.V

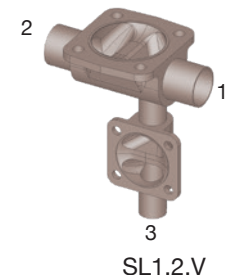

SL1.2.V

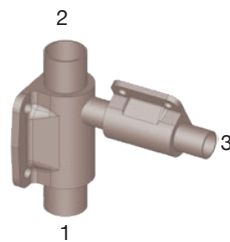

SL2.1.H

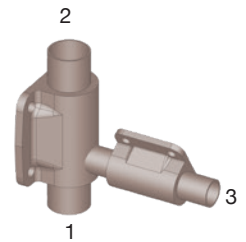

SL1.1.H

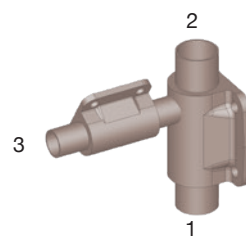

SL2.2.H

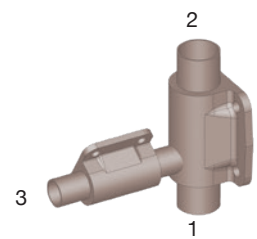

SL1.2.H

On request, all dimensional data sheets or 2D and 3D - CAD drawings are available.

All fabricated 2/2 way SA and SL orientations will have a dead leg. Manufacturing these valve orientations from a solid block body will minimize or eliminate the dead leg. See page 70 – 83.

Welded Valve Configurations

2) SA – Sterile Access Configurations

The Sterile Access Fabrication is utilized in a horizontal piping system where the main valve is orientated at the self-draining angle and the access port is at the lowest drainable point of the waterway.

The sterile access maybe used for applications including sampling, steam, condensate or divert port.

The Sterile Access Fabrication is available with either a tube port or a vertical or horizontal valve port.

The size range available is up to DN 100 (4") for both the main valve and access valve or tube port.

Sterile access fabrications use two standard 2/2 way valve bodies welded together per the required orientation. In some same size (i.e. DN25 x DN25) sterile access fabrications a block body main valve may be selected for manufacturing.

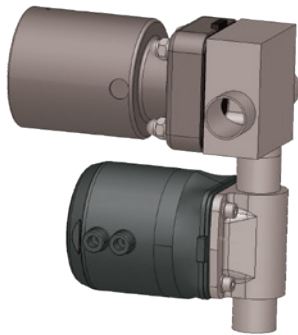

SA1.V

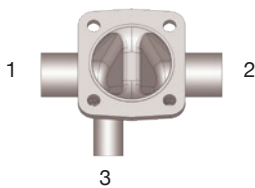

SA2.V

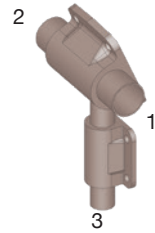
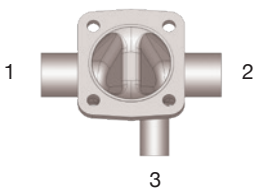

SA1.1.V

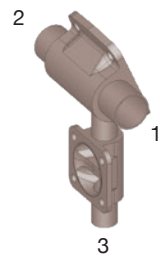

SA1.2.V

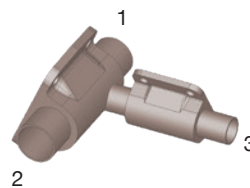

SA1.1.H

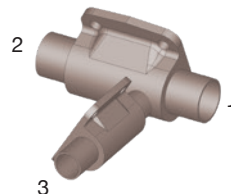

SA1.2.H

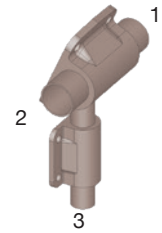

SA2.1.V

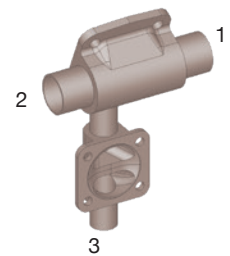

SA2.2.V

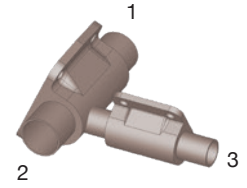

SA2.1.H

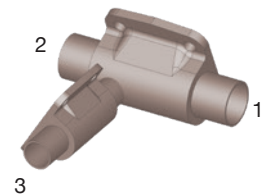

SA2.2.H

On request, all dimensional data sheets or 2D and 3D - CAD drawings are available.

All fabricated 2/2 way SA and SL orientations will have a dead leg. Manufacturing these valve orientations from a solid block body will minimize or eliminate the dead leg. See page 70 – 83.

Multiport Valves

Why Multiport Valves?

A multiport valve consists of a valve body machined from a solid block material with a minimum of three tube ends. Multiport valves can be produced with up to 20 actuators and 40 tube ends or even more depending on the feasibility of multiport valve manufacturing. The selection and specification of multiport valves in the aseptic process industry becomes more and more important. The reason is found in the advantages the product offers in optimizing aseptic process purity and efficient product manufacturing.

Innovative conceptual designs and modern machining capabilities are integrated through the CAD-CAM system creating profitable individual solutions with a high degree of flexibility. A prerequisite for this is an operational structure which supports a close relationship between sales, engineering and manufacturing. With a high vertical range of manufacturing at its factory, SED is in an excellent position to meet these challenging market needs. The continuous innovative development of multiport block valve products is a main focus of SED.

The ideal benefit for you, our customer, is achieved through active and cooperative teamwork of both parties during the design and specification of the valves. This refers especially to the process requirements dictated by the P&ID's for proper flow direction, drainability and installation restraints.

The below illustrations compare the hold up volume and the compact design of a multiport block valve to a welded valve configuration:

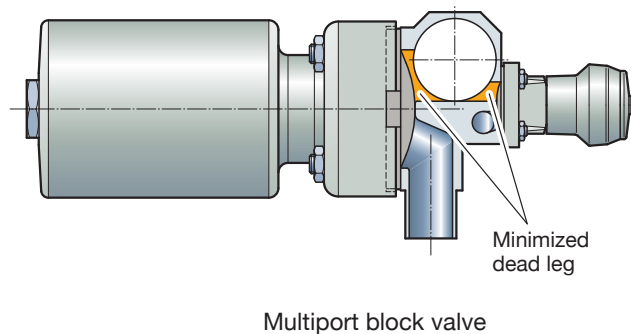
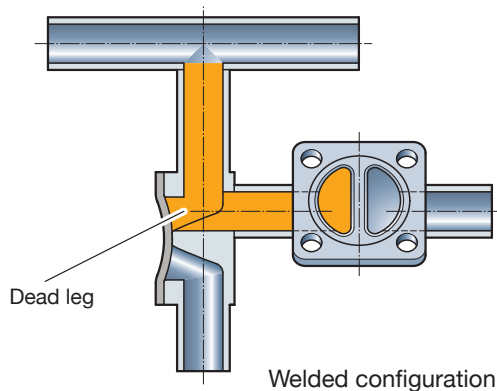

The complete drainability is an important consideration for the design of multiport valves. The following illustration shows the correct and incorrect installation of a standard T-valve:

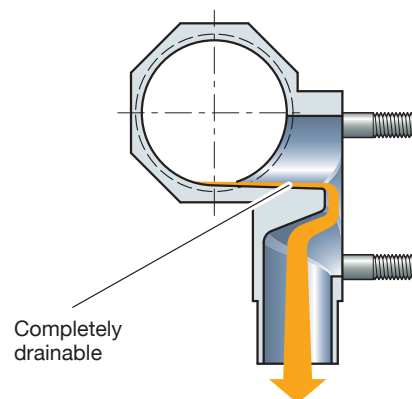
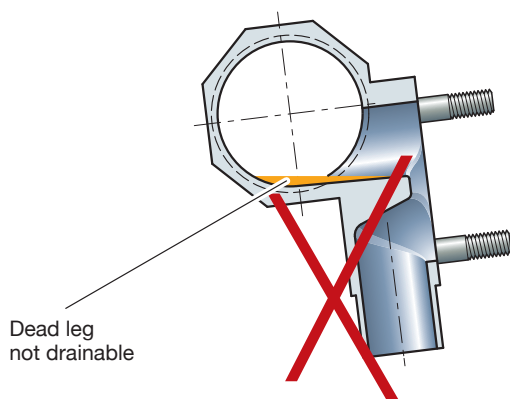

The Advantages at a Glance:

- Customer's specific design
- Compact design and smaller envelope dimension is achievable with the Steripur Series actuators
- Combination of many different nominal diameters
- Optimized drainability
- Minimized dead leg
- Reduces surface contact, hold up volume and cross contamination of the product
- Reduction of fittings, tubing and field welds in the system
- Reduces qualification and validation documentation requirements
- All end connections and materials are available according to the customer's specification

The application of multiport block valves is mainly for the distribution, point of use, sampling, diverting, mixing, bypass, drain and process sterilization (SIP/CIP).

Multiport Valves

The following Multiport Valve pages display a selection of multiport block valves. These are examples that should assist in specifying the multiport block body. Up to size DN100 (4.0") and larger nominal diameters and nominal diameter combinations are available. Within this range, all tube standards, tube end orientations, and other application specific customized blocks can be specified. Some of the multiport block valves have become standard products for SED and years of development and manufacturing has allowed for efficiency in production.

For the differentiation in the following tables, two main criteria are considered:

- 1) Multiport blocks with main line open for circulation (page 71 to 75)
- 2) Multiport blocks with all lines and valve ports able to close (page 76 to 81)

1) Main line open

T-Valve or ZDL-Valve

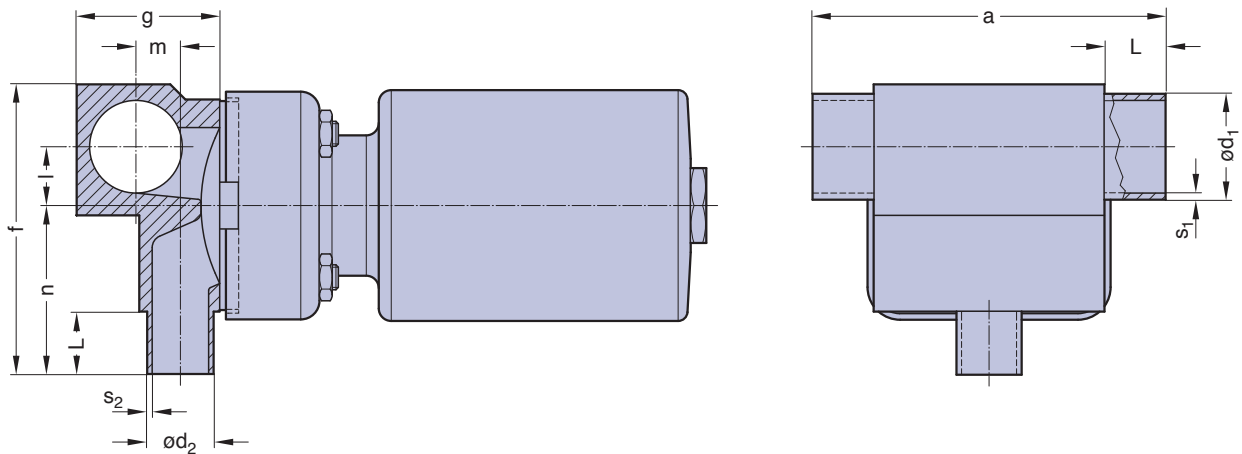

On request, all dimensional data sheets or 2D and 3D - CAD drawings are available.

Description

For valve specification see page 83 as guideline

P&ID

- Flow direction
- Drain direction
- ⊗ Valve

Illustration

Actuators and other options are included in some of the illustrations

1.1)

T-Valve or ZDL-Valve

1 x Point of use or sampling valve port
Optional available with U-bend for easy fit into the loop

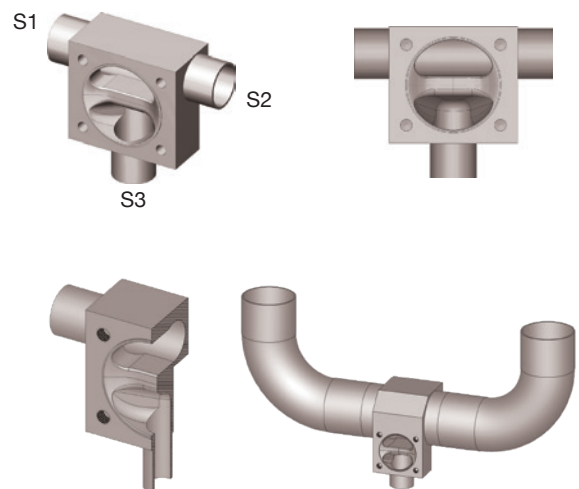
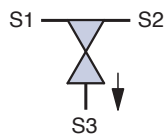

Recommended installation:
S3 down

Multiport Valves

1) Main line open

Description

For valve specification see page 83 as guideline

P&ID

- ⇒ Flow direction
- Drain direction
- ⊘ Valve

Illustration

Actuators and other options are included in some of the illustrations

1.15)

TL- Valve, actuation left side
(illustration)

TR-Valve, actuation right side

1 x Point of use or sampling valve port

Main line vertical

Recommended installation:
S3 - 45° down

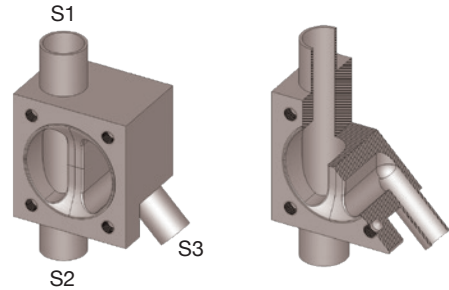
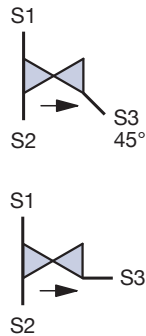

1.16)

TH- Valve

1 x Point of use or sampling valve port

Main line vertical and with horizontal outlet port

Recommended installation:
S2 down

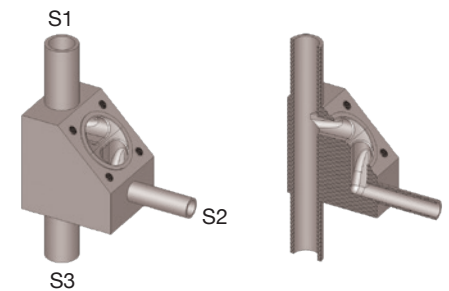
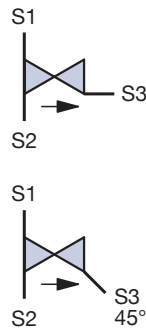

1.2)

LL 3/1 - S2 left side

(illustration)

LR 3/1 - S2 right side

1 x Point of use valve port with integrated directional flow 90° to the main line

Recommended installation:
S3 down

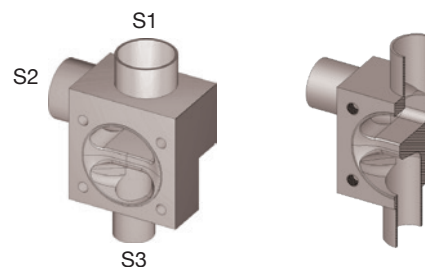
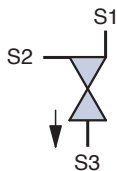

1.13)

TY-Valve

2 x Point of use or sampling valve ports

Optional available with U-bend for easy fit into the loop

Recommended installation:
S3 and S4 - 45° down

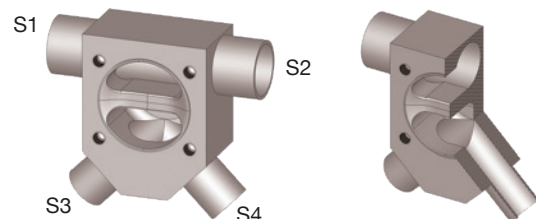
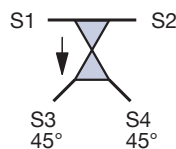

Multiport Valves

1) Main line open

Description

For valve specification see page 83 as guideline

P&ID

- ⇒ Flow direction
- ➔ Drain direction
- ⊘ Valve

Illustration

Actuators and other options are included in some of the illustrations

1.4)

MZL 4/2 – S4 left side
MZR 4/2 – S4 right side

(illustration)

1 x Point of use valve port
1 x Integral loop sample valve port
Sample valve be provides on either side of the valve body.

Back to back valve actuation

Recommended installation:
S3 down

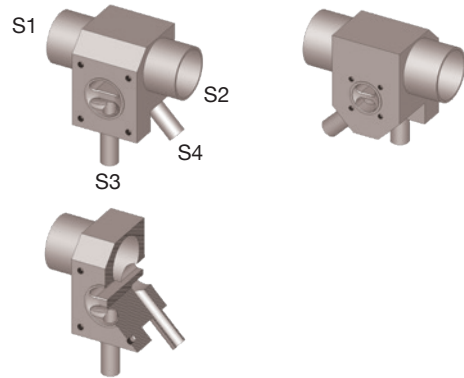
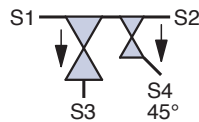
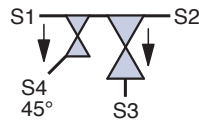

1.45)

MTL 4/2 – S4 left side
MTR 4/2 – S4 right side

(illustration)

2 x Point of Use Valve Port or
Double Zero Dead Leg Tee Valve
with different diaphragm size.

One port maybe used for sampling
and the second port for
downstream processing.

One side valve actuation

Recommended installation:
S3 and S4 down

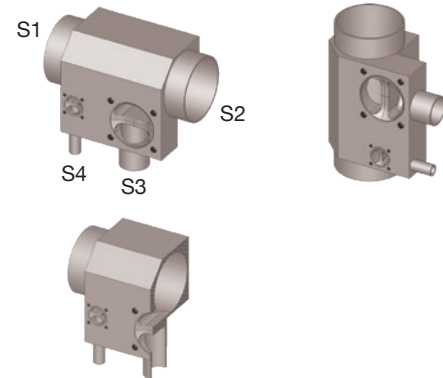
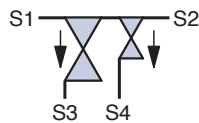
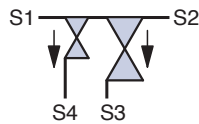

1.6)

MXL 4/2 – S4 left side
MXR 4/2 – S4 right side

(illustration)

1 x Point of use valve port
1 x Integral sample purge valve,
valve port below the weir.

Sample valve be provides on
either side of the valve body.

Back to back valve actuation

Recommended installation:
S3 down

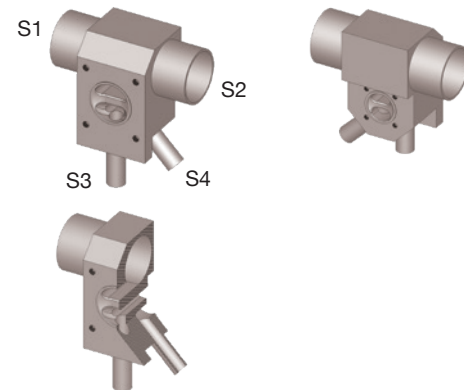
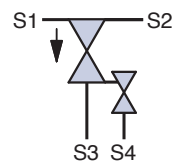
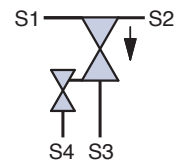

1.61)

MKL 4/2 – S4 left side
MKR 4/2 – S4 right side

(illustration)

1 x Point of use valve port
1 x Integral sample purge valve,
valve port below the weir.

Sample valve be provides on
either side of the valve body.

**No valve actuation on the
back side**

Recommended installation:
S3 down

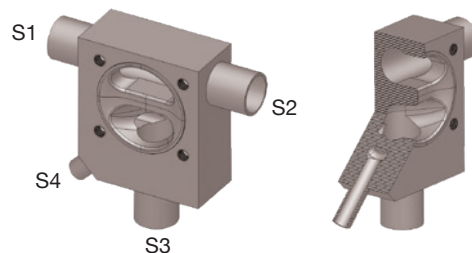
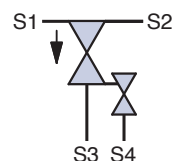
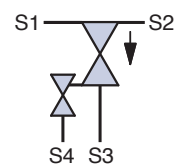

Multiport Valves

1) Main line open

Description

For valve specification see page 83 as guideline

P&ID

- Flow direction
- Drain direction
- ⊘ Valve

Illustration

Actuators and other options are included in some of the illustrations

1.7)

MWL 5/3 – S4 left side

(illustration)

MWR 5/3 – S4 right side

1 x Point of use valve port

1 x Integral loop sample valve port

1 x Integral sample purge valve port below the weir.

Sample and purge valve be provides on either side of the valve body.

Back to back valve actuation

Recommended installation:

S3 down

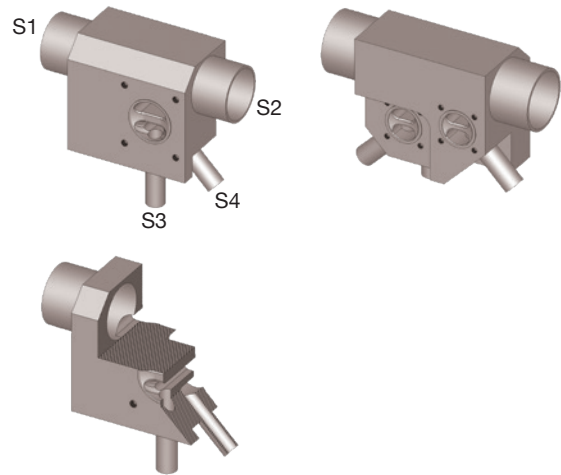
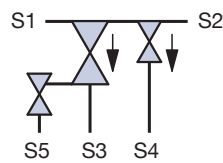
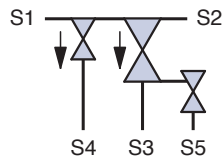

1.72)

MVL 5/3 – S4 left side

(illustration)

MVR 5/3 – S4 right side

1 x Point of use valve port

1 x Integral loop sample valve port

1 x Integral sample purge valve port below the weir.

Sample and purge valve be provides on either side of the valve body.

No valve actuation on the back side

Recommended installation:

S3 down

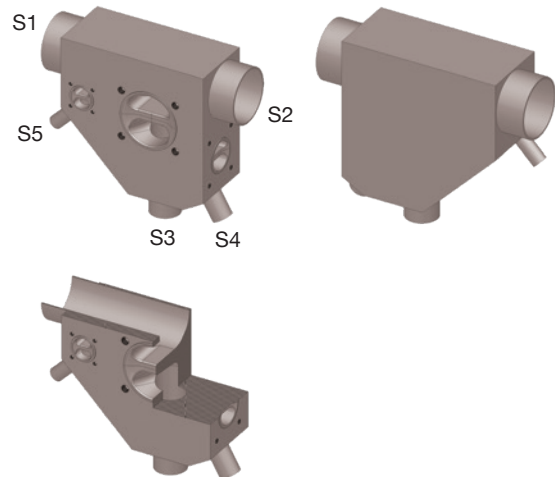
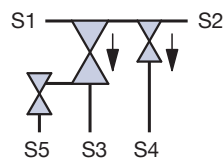
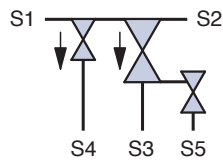

1.9)

MTE 6/4

4 x Point of use valve ports

The Number of valve ports is variable.

No valve actuation on the back side

Recommended installation:

S1 and S2 horizontal

S3 to S6 vertical down or vertical up orientation.

S1 and S2 can be vertical if tube outlets S3 to S6 are positioned to the lowest point of valve pocket like the picture shows

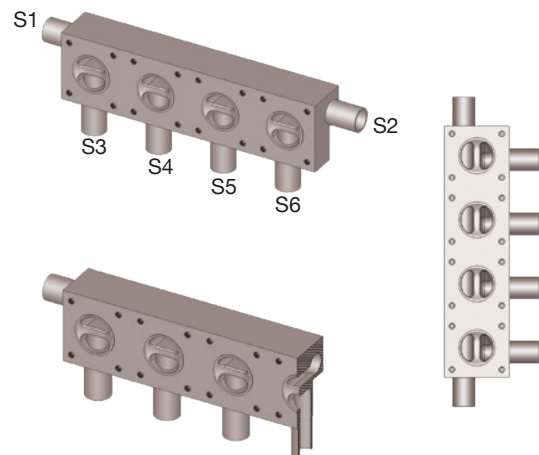
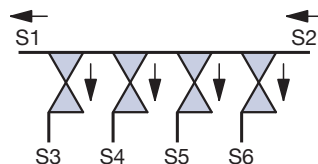

Multiport Valves

1) Main line open

Description

For valve specification see page 83 as guideline

P&ID

- ⇒ Flow direction
- ➔ Drain direction
- ⊘ Valve

Illustration

Actuators and other options are included in some of the illustrations

1.11)

MTD 7/5

5 x Point of use valve ports
The number of valve ports is variable.

Back to back valve actuation

Recommended installation:
S1 and S2 horizontal
S3 to S7 can be vertical if tube outlets S3 to S7 are positioned to the lowest point of valve pocket like the picture shows.

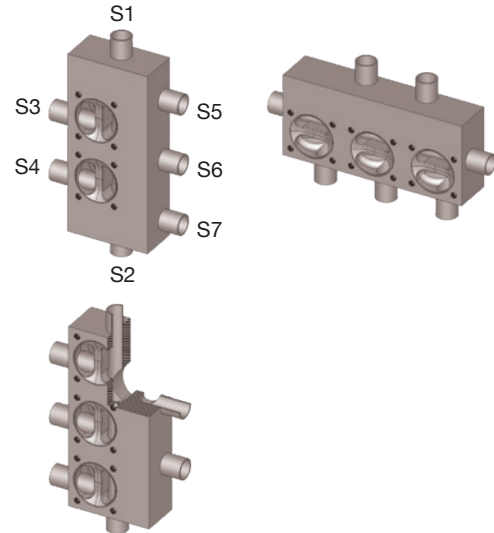
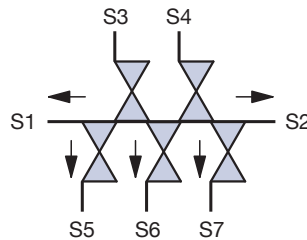

1.14)

MCE 4/2 to 16/14

2 to 14 Point of use valve ports
The number of valve ports is variable

No valve actuation on the back side

Recommended installation:
S1 and S2 horizontal
S3 to S4 or max S16 down or vertical up orientation.
S1 and S2 can be vertical if tube outlets S3 to S4 or max S16 are positioned to the lowest point of valve pocket like the picture shows.

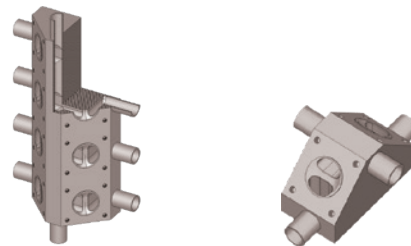
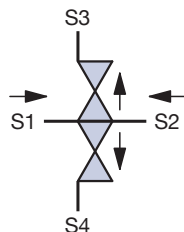
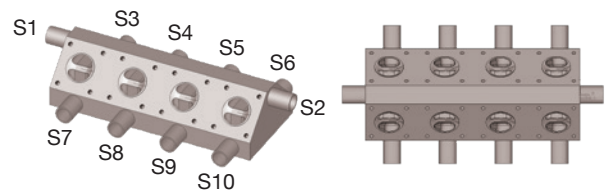
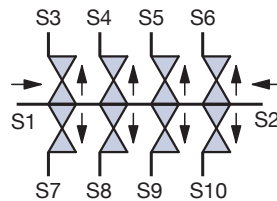

1.16)

MFF 4/2 to 32/30

Up to 30 point of use valve ports as flexible manifold system

Dependent on the requirements the number of valves installed can be between 2 and 30.
It is a mirror design to be suitable also for applying clamp connection.
It allows standardizing skids and other system solutions.
Aseptic O-ring connection according ASME/BPE and DIN 11864 see also catalogue page 23

Back to back valve actuation

Recommended installation:
S4 down

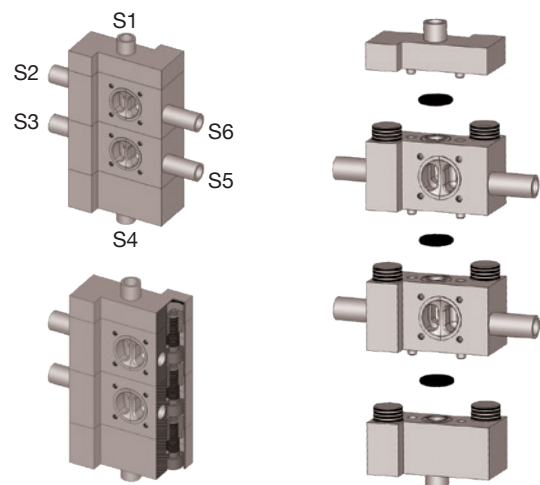
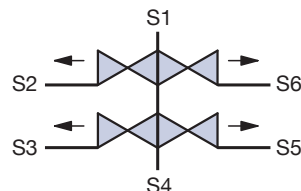

Multiport Valves

2) All lines and valve ports able to close

Description

For valve specification see page 83 as guideline

P&ID

- Flow direction
- Drain direction
- ⊠ Valve

Illustration

Actuators and other options are included in some of the illustrations

2.1)

MFE 3/2

- 1 x Valve horizontal
- 1 x Valve vertical

Back to back valve actuation

Recommended installation:
Dependent on design and application

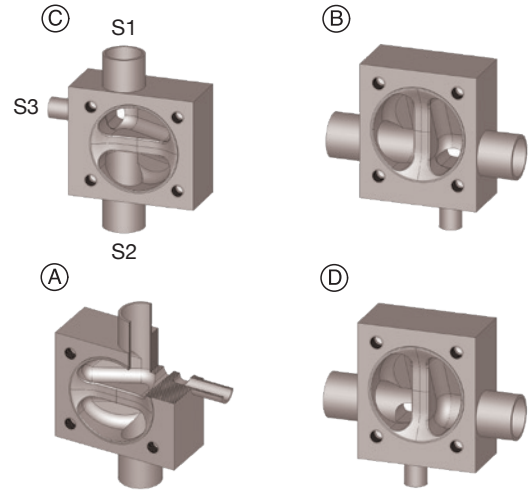
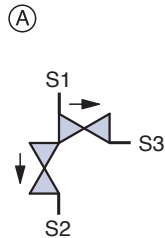

2.15)

MBE 3/2

- 1 x Valve horizontal
- 1 x Valve vertical

Function similar to pos. 2.1 but

No valve actuation on the back side

Recommended installation:
Dependent on design and application

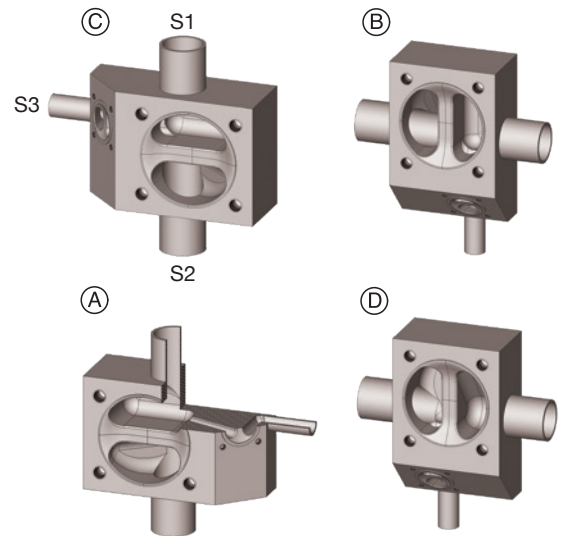
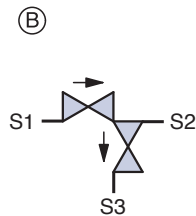

2.16)

MPE 3/2

- 1 x Valve horizontal
- 1 x Valve vertical

Illustration shows one version only.

Function similar to pos. 2.1 but one side valve actuation

Recommended installation:
Dependent on design and application

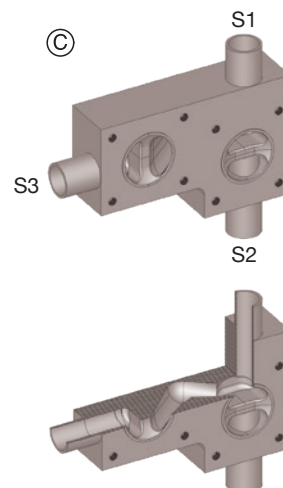
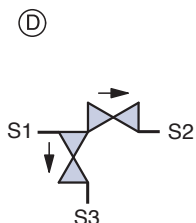

Multiport Valves

2) All lines and valve ports able to close

Description

For valve specification see page 83 as guideline

P&ID

- Flow direction
- Drain direction
- ⊘ Valve

Illustration

Actuators and other options are included in some of the illustrations

2.25)

MFE 3/2

2 x Valve horizontal

Back to back valve actuation

Recommended installation:
S1 vertical down or vertical up
Dependent on design and application

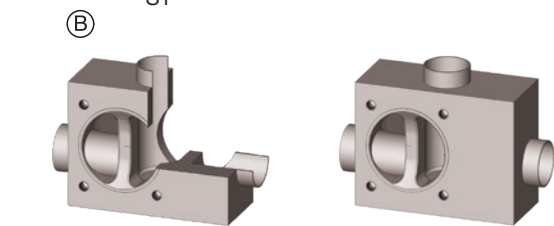
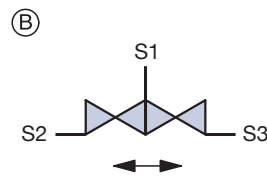
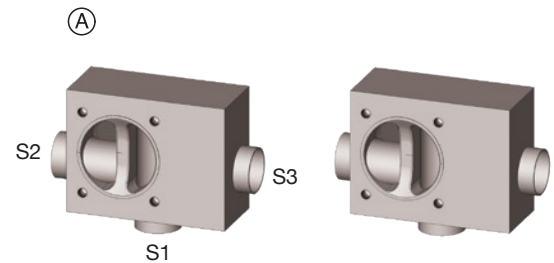
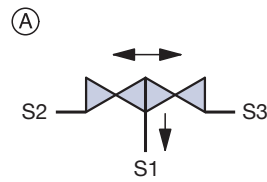

2.31)

MCE 3/2

2 x Valve horizontal

Function similar to pos. 2.25 but
no valve actuation on the back side

Recommended installation:
S1 horizontal or vertical
The 2-way divert valve block body allows for many different inlet and outlet orientations. Some of them are illustrated

(A) + (B)

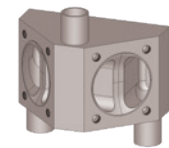
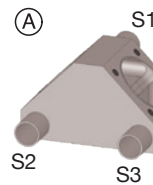
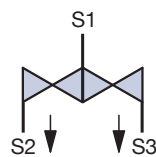

(C)

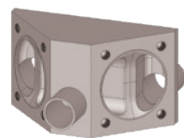
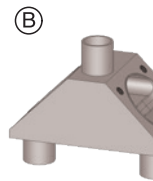
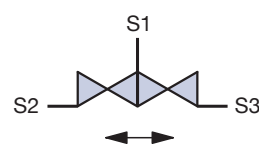

(C)

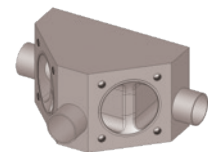
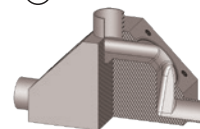

2.35)

MFE 3/3

2 x Valve horizontal

1 x Valve vertical

Back to back valve actuation

Recommended installation:
S3 vertical down or vertical up

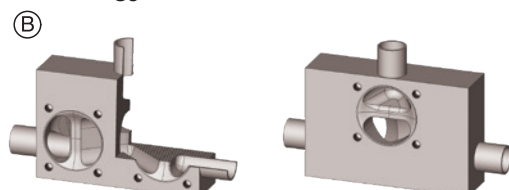
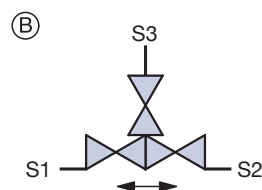
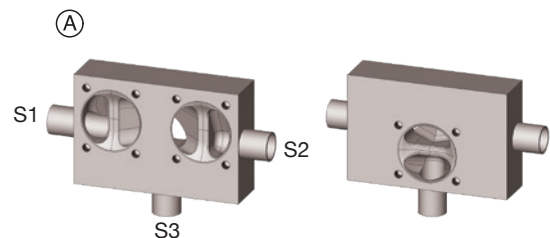
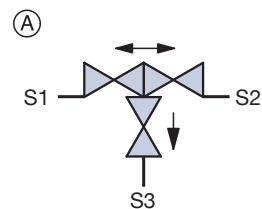

Multiport Valves

2) All lines and valve ports able to close

Description

For valve specification see page 83 as guideline

P&ID

- ⇒ Flow direction
- Drain direction
- ⊘ Valve

Illustration

Actuators and other options are included in some of the illustrations

2.38)

MCE 3/3

2 x Valve horizontal

1 x Valve vertical

Function similar to pos. 2.35 but

no valve actuation on the back side

Recommended installation:

S3 vertical down or vertical up

The valve block body allows for many different inlet and outlet orientations.

Some of them are illustrated

Dependent on design and application

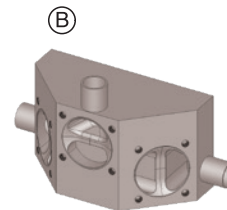
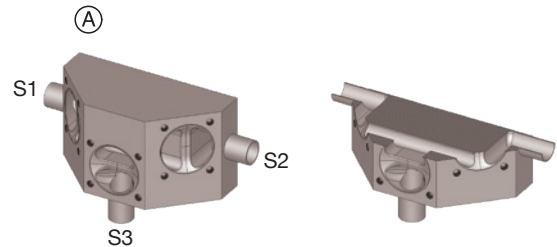
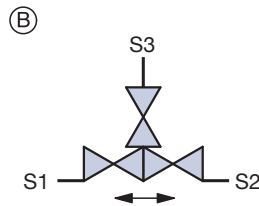
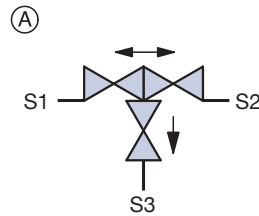

2.41)

MFE 4/3

1 x Valve horizontal

2 x Valve vertical

Back to back valve actuation

Recommended installation:

Main line isolation through S3 and S4, S1 vertical up sterili-

zation valve port, S2 vertical down sterilization valve port.

Or S3 and S4 vertical dependent on design and application.

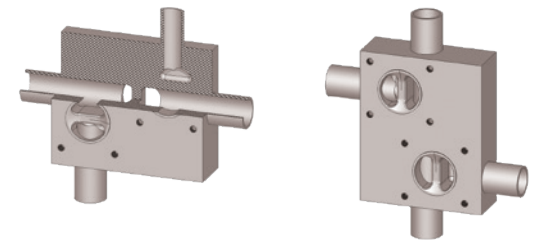
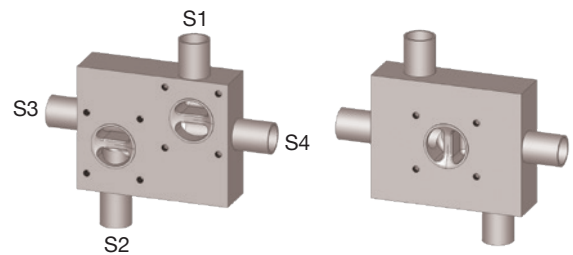
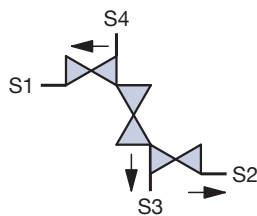
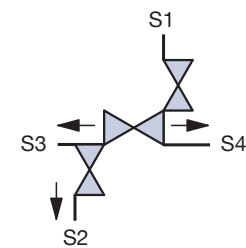

2.43)

MFE 4/3

1 x Valve horizontal

2 x Valve vertical

Back to back valve actuation

Recommended installation:

S2, S3 vertical down or

dependent on design

and application

S4 vertical down.

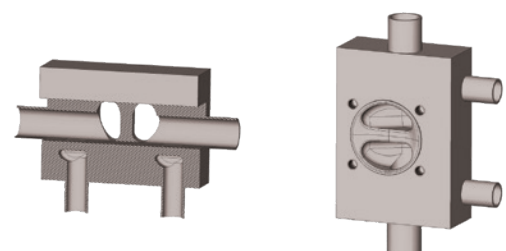
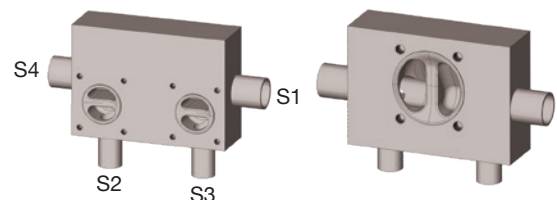
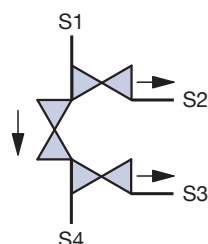
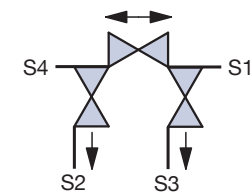

Multiport Valves

2) All lines and valve ports able to close

Description

For valve specification see page 83 as guideline

P&ID

- ⇒ Flow direction
- Drain direction
- ⊠ Valve

Illustration

Actuators and other options are included in some of the illustrations

2.49)

MFE 4/4

2 x Valve horizontal
2 x Valve vertical

Back to back valve actuation

Recommended installation:
S2 vertical down

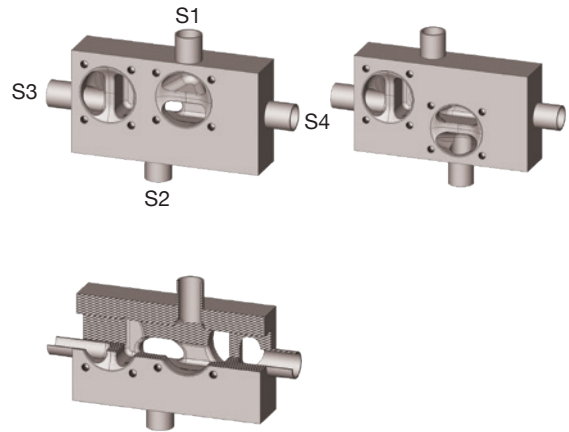
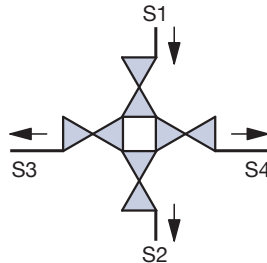

2.51)

MBE 4/4

2 x Valve horizontal
2 x Valve vertical

Function similar to pos. 2.35 but
no valve actuation on the back side

Recommended installation:
S2 vertical down or
S1 and S2 horizontal
The valve block body allows
for many different inlet and
outlet orientations.
Dependent on design and
application

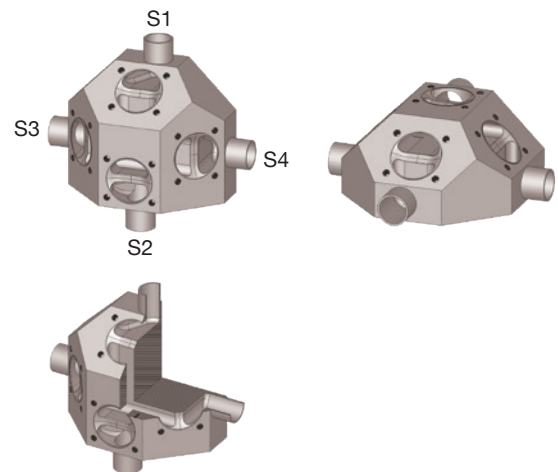
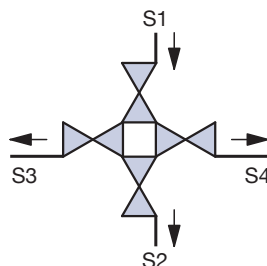

2.71)

MFE 5/4

2 x Valve horizontal
2 x Valve vertical

Back to back valve actuation

Recommended installation:
S3, S4, S5 vertical down
Dependent on design and
application
S3, S4, S5 vertical up

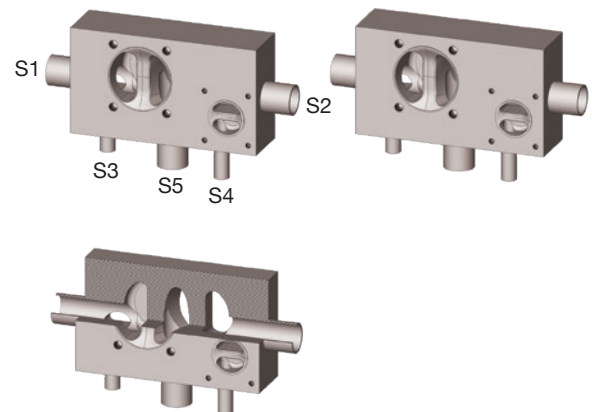
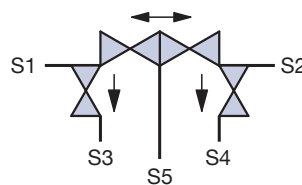

Multiport Valves

2) All lines and valve ports able to close

Description

For valve specification see page 83 as guideline

P&ID

- ⇒ Flow direction
- Drain direction
- ⊘ Valve

Illustration

Actuators and other options are included in some of the illustrations

2.72)

MFE 4/4

2 x Valve horizontal
2 x Valve vertical

Back to back valve actuation

Recommended installation:
S3 and S4 vertical down
Dependent on design
and application
S3 and S4 vertical up

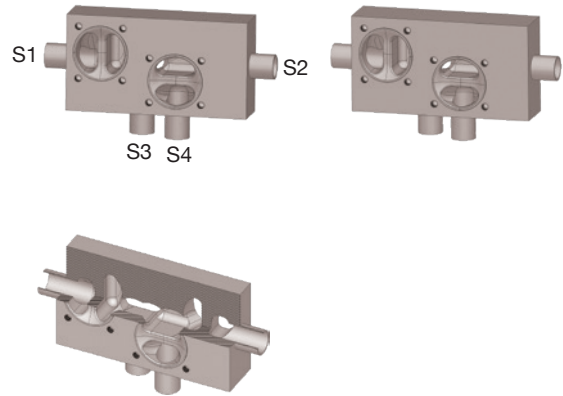
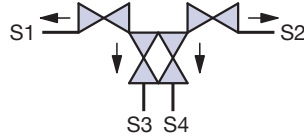

2.73)

MFE 4/4

2 x Valve horizontal
2 x Valve vertical

Back to back valve actuation

Recommended installation:
S3 and S4 vertical down
Dependent on design
and application
S3 and S4 vertical up

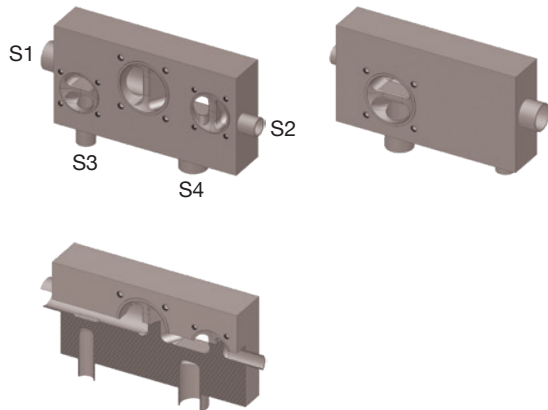
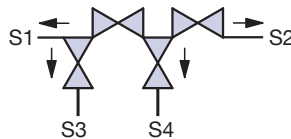

2.8)

MDE 4/4

no valve actuation on the back side

Chromatography valve without bypass

MDE 4/5

no valve actuation on the back side

Chromatography valve with bypass

Recommended installation:
S2 and S4 horizontal
S1 and S3 horizontal.
Or S1 to S4 horizontal

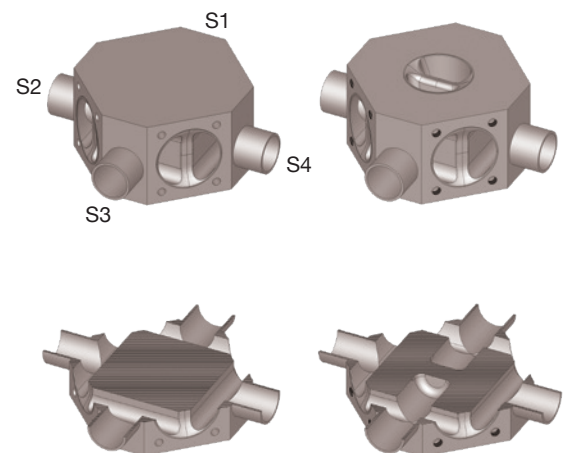
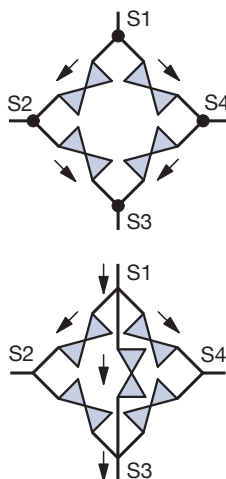

Multiport Valves

2) All lines and valve ports able to close

Description

For valve specification see page 83 as guideline

P&ID

- Flow direction
- Drain direction
- ⊘ Valve

Illustration

Actuators and other options are included in some of the illustrations

2.9)

MCS 4/3 Star Design
3x Valves vertical

MCS 5/4 Star Design
4x Valves vertical

MCS 6/5 Star Design
5x Valves vertical

no valve actuation on the back side

Recommended installation:
S1 vertical; Depending on the diameter the star design is available with up to 7 valves.

The star design has also been manufactured with two opposing multiport block valves with one common port connection.

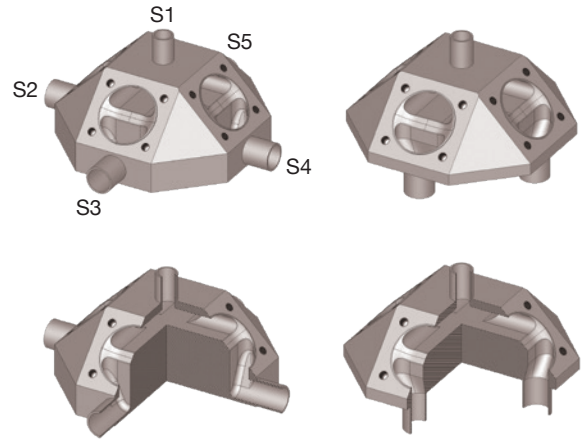
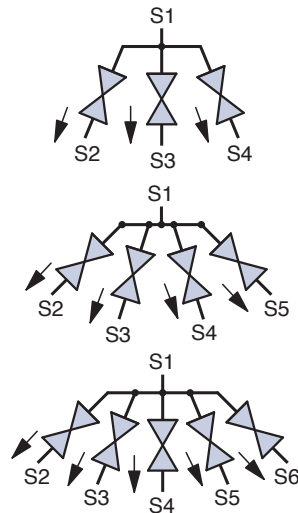

2.91)

MTA 5/5

5 Valves horizontal with one for drainage

no valve actuation on the back side

Recommended installation:
S5 as drainage valve.

Different inlet and outlet orientations e.g. S5 as inlet valve.

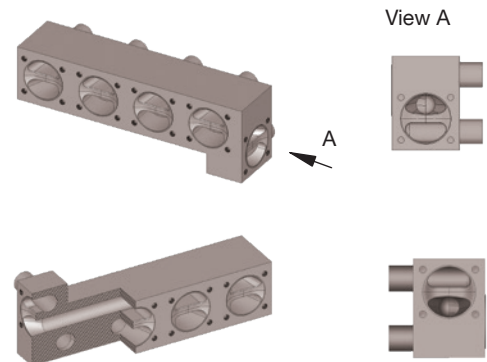
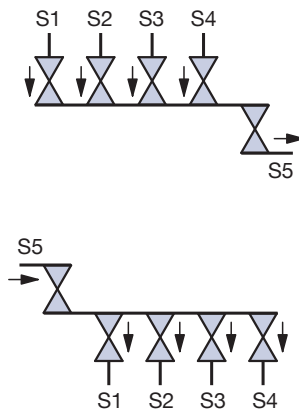

2.95)

MTE 5/5

5x Valve horizontal or vertical.

Back to back valve actuation

Recommended installation:
S1 to S5 vertical

S1 to S5 can be horizontal if the tubes positioned to the lowest point of the valve pocket
This block solution may be used for mixing, diverting, isolation or sterilization.

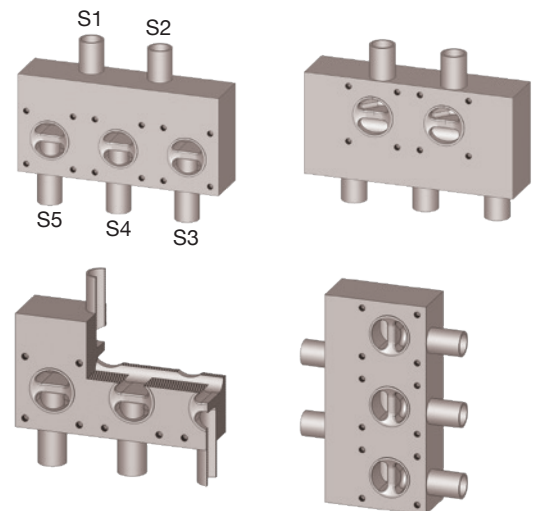
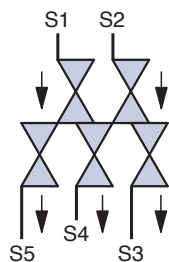

Multiport Valves

The way of customized multiport valve designs

From the piping and instrumentation diagram (P&ID) to the finished plant installation of pharmaceutical and bio pharm projects.

P&ID Multiport Valve Cluster

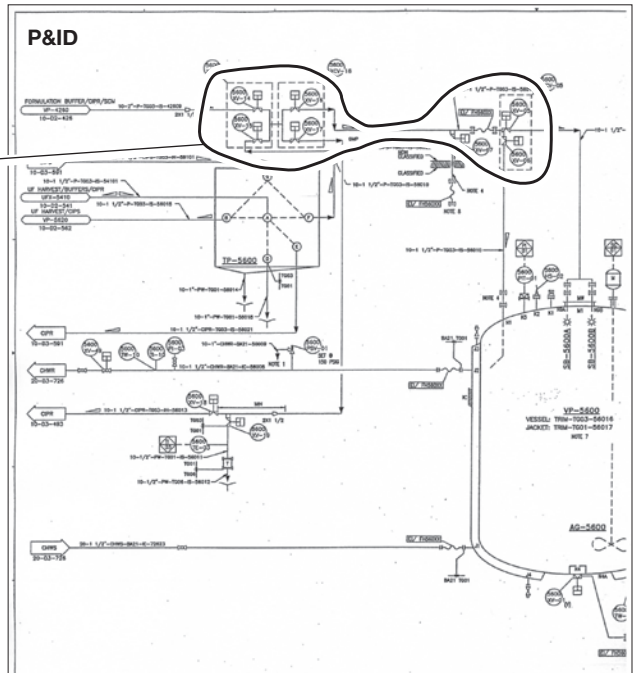
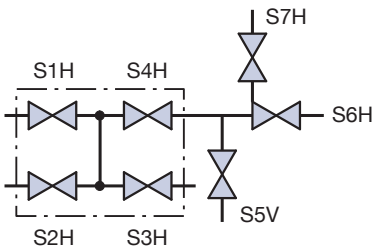

Drawing Multiport Valve Cluster

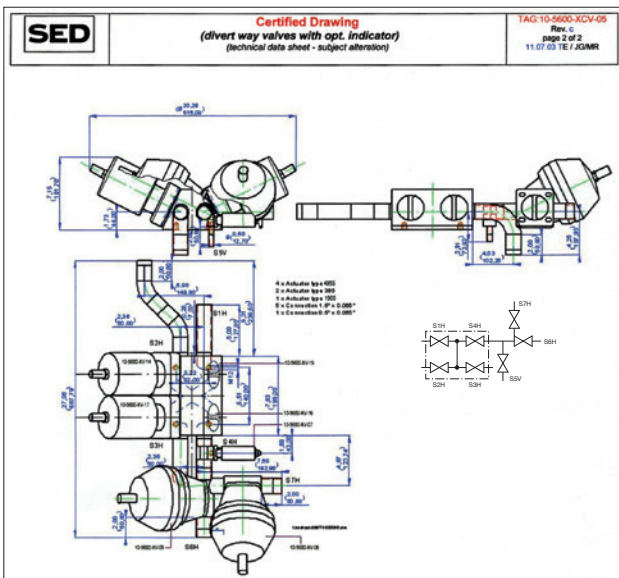

Images of the installation

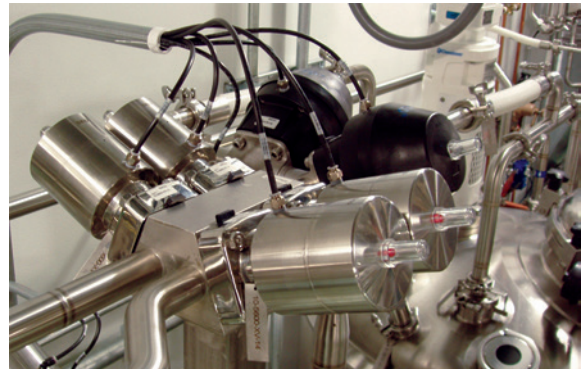

Multiport Valve Cluster



Multiport Valves

Specification

Your P&ID Sketch:

Example: P&ID

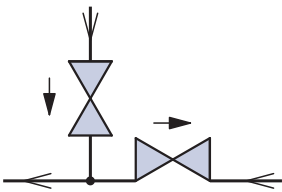

Tube End: S1, S2, ...

Preferred Installation: Horizontal (H) / Vertical (V)

Flow Direction: \Rightarrow

Drain Direction: \rightarrow

Valve Seat: 

Working pressure: _____ bar

Working temperature: _____ °C

Multiport valve body material:

1.4435/316L

1.4435/316L (Fe < 0,5%)

Other _____

Surface finish multiport body:

02	Ra ≤ 0,8 μm	<input type="checkbox"/>
03	Ra ≤ 0,8 μm e-polished	<input type="checkbox"/>
07	Ra ≤ 0,6 μm	<input type="checkbox"/>
08	Ra ≤ 0,6 μm e-polished	<input type="checkbox"/>
09	Ra ≤ 0,4 μm	<input type="checkbox"/>
10	Ra ≤ 0,4 μm e-polished	<input type="checkbox"/>

Diaphragm material:

EPDM Code _____

PTFE Code _____

Other _____

Page in catalogue:

Page 21

Page 26 - 27

Page 108 - 115

Tube end No	Preferred Installation	Tube end connection				Actuator		Other
		DN	s[mm]	D[mm]	Code	Actuator Type	Control Function	Accessories / Comments
S1								
S2								
S3								
S4								
S5								
S6								
S7								
S8								
S9								
S10								
S11								
S12								

Tank Valves

The SED Tank Bottom Valve is designed for applications in the aseptic process industry offering a pocket-free interior surface, minimized sump, eliminating entrapment areas and minimizing flow resistance thus reducing the potential for process contamination. The SED tank bottom valve incorporates the same features and performance of a standard diaphragm valve utilizing the same valve components for a flush mounted tank bottom valve or side mounted tank and sample valve.

The tank valve body is machined as standard from solid bar stock material 1.4435/316L ASME BPE and other alloy materials are available according to the specification. The standard design offers one valve port outlet. There are a number of different options available for sampling, sterilization and multi-outlet configurations that are standard in the SED product range of customized solutions.

It is preferred to weld in the tank valve directly in the vessel. Mounting the valve directly to the tank minimizes the hold up volume, the most important criteria for this application. If removal of the tank valve from the tank is required, versions are offered with flange or clamp connections. Please consult an SED technical representative for these options.

Tank bottom valves are typically used for tank discharge, draining, sampling, cleaning and/or sterilizing, rinsing and isolation of down stream processing.

The outlet port of the tank valve is available with all butt weld tube end standards (see fold-out page 21), aseptic clamp, screw connection (see page 22 and 23) or other special ends. The size range available is the same as the two-way valve.

Features:

- Tank body machined from a solid bar stock material
- Material 1.4435/316L ASME BPE
- Other alloy options available as specified
- Minimized dead leg and internal sump
- Suitable for mounting with SED Steripur Series and KMA Series Actuation
- Optional manual operation via an extended crankshaft stem

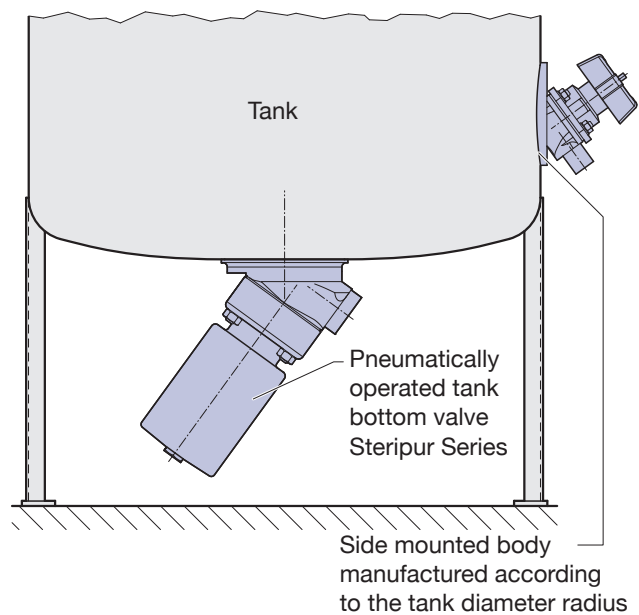
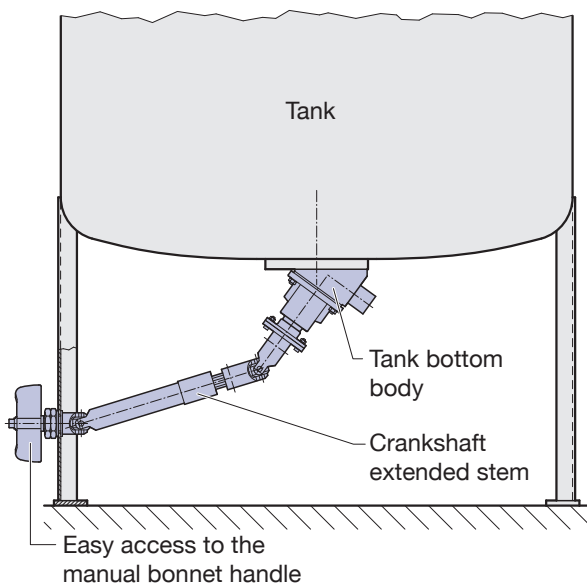

Steripur Series Manual



Steripur Series Pneumatically Operated



KMA Series Manual



KMA Series Pneumatically Operated



Tank Valves

Example:
Drawing Steripur Series pneumatically operated

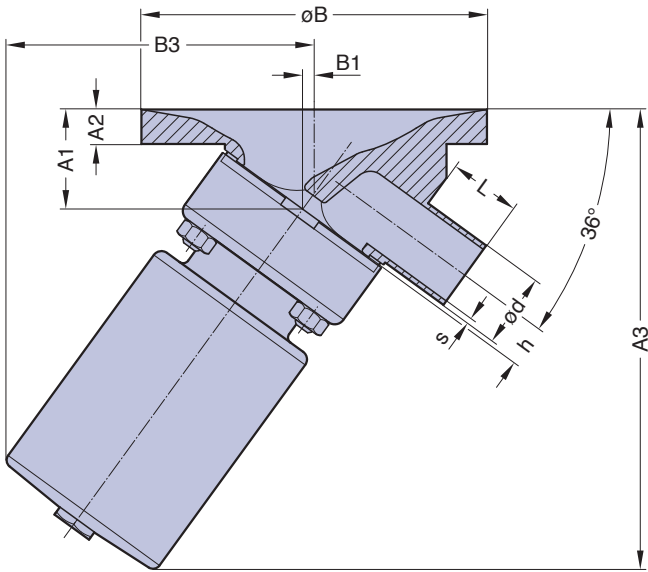

Common design

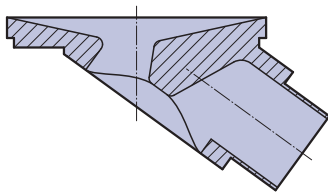

Example:
Drawing KMA Series manually operated

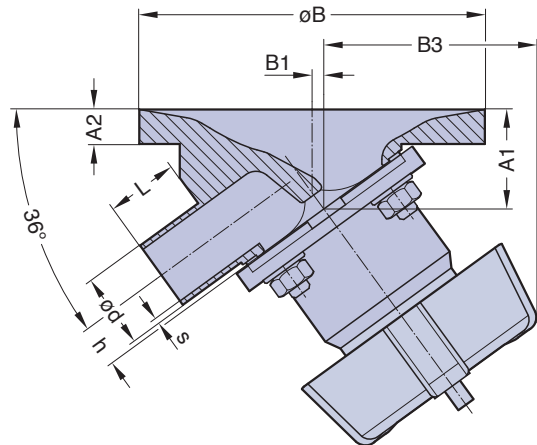

Advantages of the SED design:

- minimized hold up volume
- better mixability of media

On request, all dimensional data sheets or 2D and 3D - CAD drawings are available.

These include options for sampling, sterilization, and multi-outlet configurations.

The following two pages show a table of some examples of standard and customized designs of tank diaphragm valves.

Description

Select a tank valve or see page 83 to sketch and specify your solution

P&ID

- Flow direction
- Drain direction
- ⊗ Valve

Image

Actuators and other options are included in some of the illustrations

1)

BT

1x Valve port

Standard tank bottom body

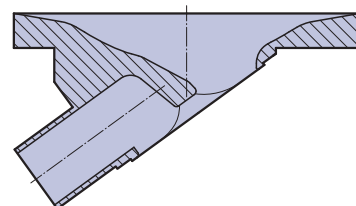
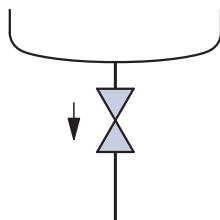

Tank Valves

Description

Select a tank valve or see page 83 to sketch and specify your solution

P&ID

→ Flow direction
 → Drain direction
 Valve

Image

Actuators and other options are included in some of the illustrations

2) 1x Valve machined from bar stock

BZL 3/1 with one welded valve tank side left

BZR 3/1 with one welded valve tank side right

BXL 3/1 with one welded valve outlet left

BXR 3/1 with one welded valve outlet right

BW 4/1 with one welded valve tank side left and one welded valve outlet right

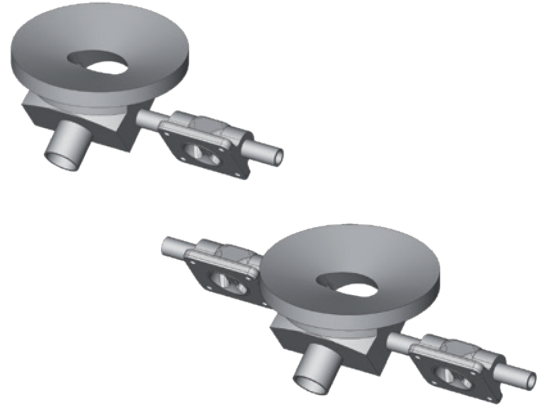
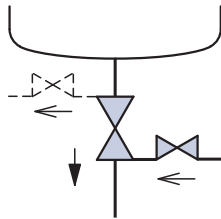

For all options the welded valve is rotated into the self draining position and extended to eliminate interference with the tank bottom

3) **BZR 3/2** (Illustration) 1x Main Valve 1x Sample valve tank side right

BZL 3/2
1x Main Valve
1x Sample valve tank side left

Like position 2 but includes an integral sample valve tank side. Right side and left side options are available and are fully drainable.

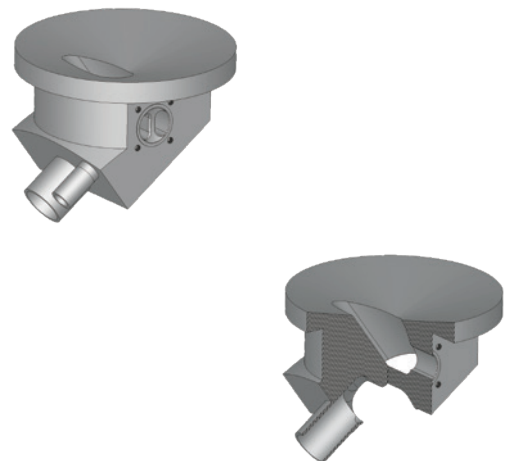
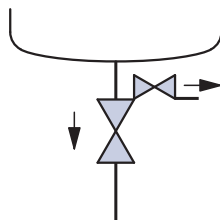

4) **BXL 3/2** (Illustration) 1x Main Valve 1x Sample valve outlet left

BXR 3/2
1x Main Valve
1x Sample valve outlet right

Like position 2 but includes an integral outlet valve. Right side and left side options are available and are fully drainable.

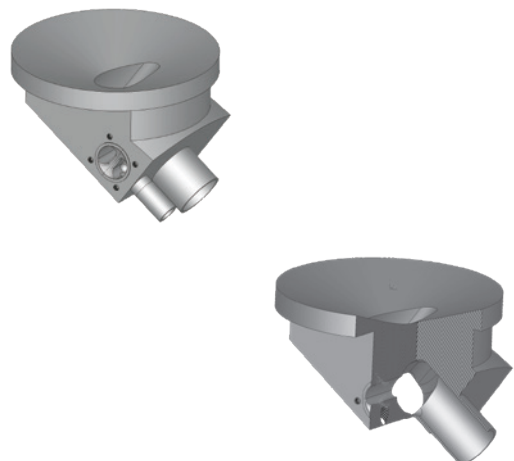
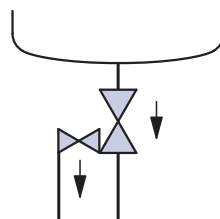

Tank Valves

Description

Select a tank valve or see page 83 to sketch and specify your solution

P&ID

- Flow direction
- ➔ Drain direction
- ⊘ Valve

Image

Actuators and other options are included in some of the illustrations

5)

BW 4/3

1x Main Valve
1x Sample valve tank side right
1x CIP/ SIP cleaning outlet valve left
Like position 2 but includes integral valves that are fully drainable.

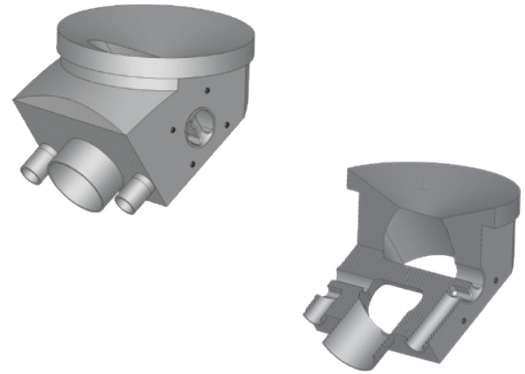
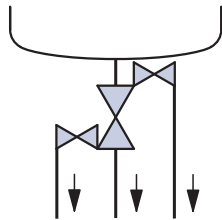

6)

BT 3/1

1x Main valve
2x Outlet port for loop installation or as two access ports

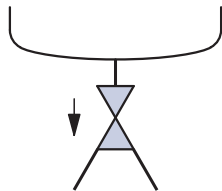

6.5)

BFL

Like position 4, but with flange for dismantling possibility

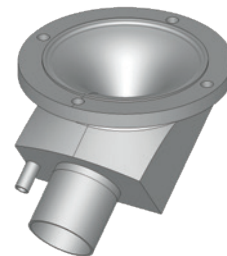
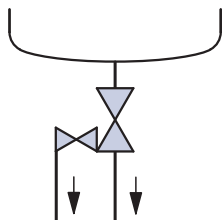

8)

BU

1x Tank wall side sample valve
All previous position options are available with the tank side sample valve.
Machined welding pad to match the radius of the tank diameter.

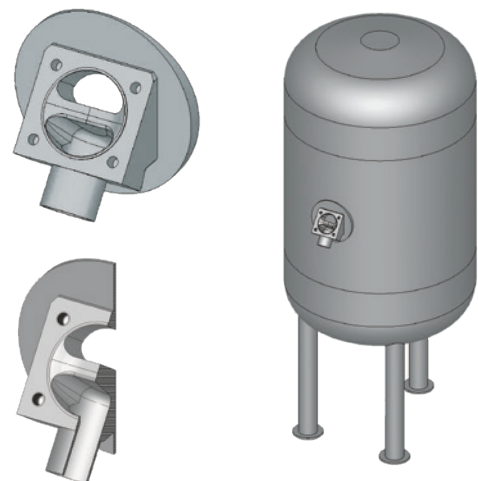
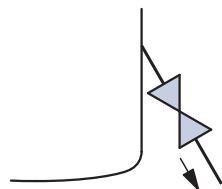

Process Solutions

Sterile Sampling Unit

The sampling unit is suitable to take sterile samples from all liquids in aseptic processes i.e. High purity water, High purity steam, Fermentation processes, Parenteral drugs, etc.

Samples can be taken in a continuous process with pneumatic controlled diaphragm valves or typically as a system with manual valves and a handle bring the complete unit in the laboratory for analyzing the sample in sterile conditions.

Advantages of the SED-Sterile Sampling Unit

- Integral valve unit directly mounted to the sampling bottle
- CIP/ SIP function in one single valve component
- Efficiency in sterilization direct from the point of use
- Autoclavable system
- Less heat transfer
- Compact design
- Material traceability available acc. to EN 10204 3.1
- Less weight

The recommended number of sampling units needed in a plant to qualify the process and continue the cycle of taking samples is:

- one unit in use for taking sample
- one unit in the cleaning
- one unit in the sterilization
- one unit for safety

Eventually more units are needed if the testing of a sample takes longer, the frequency is high, or the laboratory is far away or external from the sampling point. Depending on the process, the locations of taking samples (i.g. parenteral drugs) can be several hundreds.

There are many different valve requirements when specifying the procedure for taking samples. There are not only the valves on the sampling unit but there is also a need for a valve combination or valve block on the tank and for the condensate and CIP solution as shown on the P&ID.

For applicable designs as valve configurations see page 68, 69 and for multipoint valves see page 76.



Sampling bottle with manual valves and handle



Sampling bottle with pneumatic actuated valves

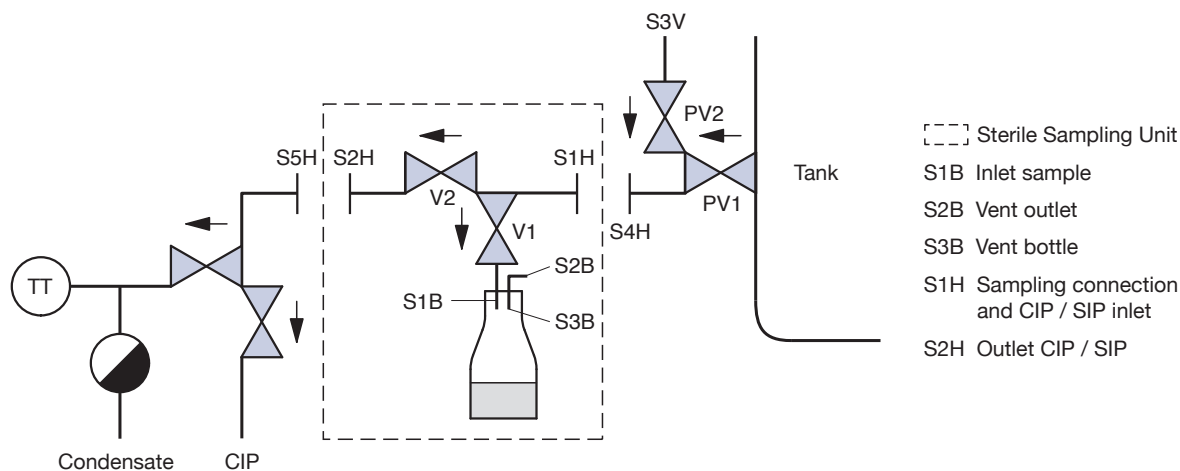

Process Solutions

Purified Steam Sampling Unit

The unit consists of a cooling coil with an integrated valve for sampling. Before taking a sample a simple sterilization of the unit is possible. By regulating the internal cooling circuit with the integrated diaphragm valve, the operator can control the temperature of the purified steam condensate. Also the diaphragm valve allows for shutting off the cooling circuit. All process connections are designed as butt weld or clamp end in order to integrate the unit easily into the process system as per customer request.

Conforming to GMP the purified sampling unit may be permanently installed or for flexible mobile use.

- Integrated diaphragm valve for sampling
- Unit easy to sterilize
- Minimized dead leg and completely self draining
- High grade stainless steel 1.4435/ 316L

Features

- High condensation performance
- Time saving sampling
- Compact design
- Tube end or clamp end connection according specification
- Integrated sampling and control valve for cooling circuit
- Easy installation due to standardized compact unit
- Unit for mobile use

Cooling capacity: approx. 0,5 l/min¹ (132 gpm)
 Condensate temperature: 30°C (86°F)
 Max. pressure vessel: 10 bar (150 psi)
 Max. pressure cooling helix: 10 to -0,9 bar (150 to -13 psi)
 Max. temperature: 150°C (302°F)
 Content cooling helix: 0,125 l (0,033 gallon)
 Weight: 6,5 kg

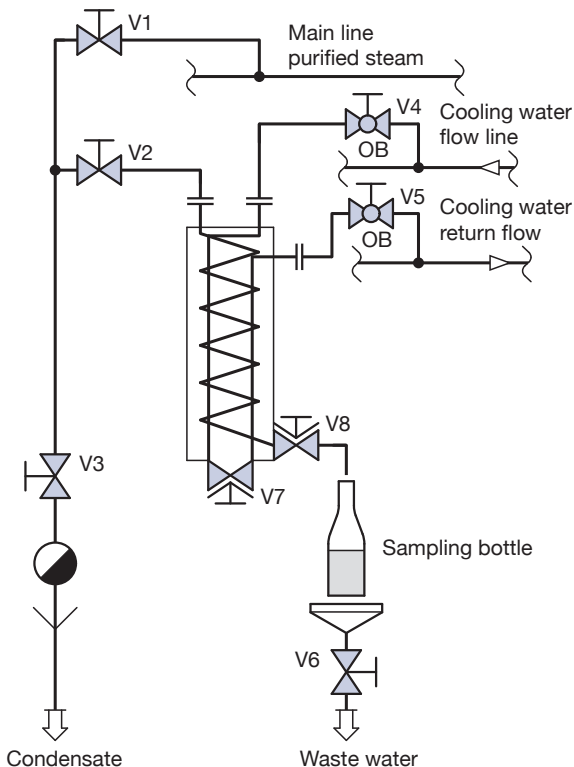
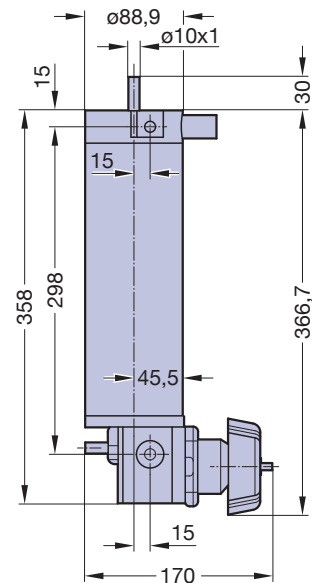
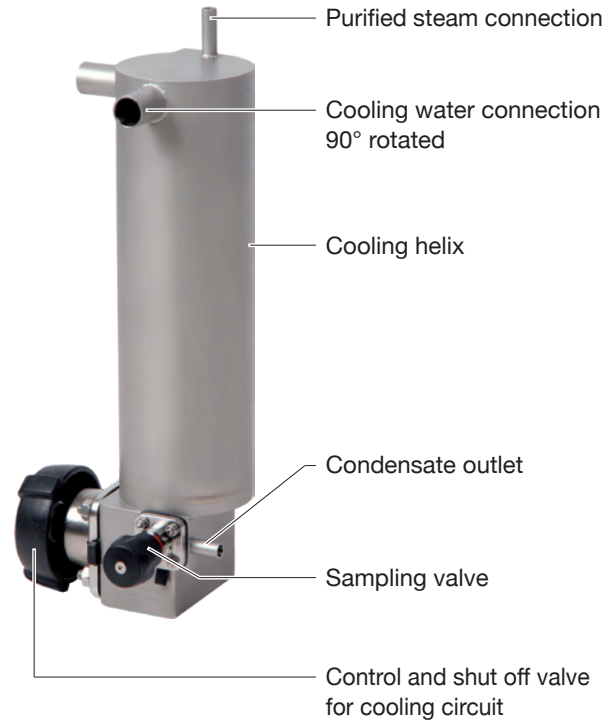

- V1** Shut off for main line purified steam
- V2** Shut off to purified sampling system
- V3** Shut off to steam trap
- V4** Shut off cooling water entering, valve blocked in open position
- V5** Shut off to cooling return flow, valve blocked in open position
- V6** Shut off to drainage
- V7** Diaphragm valve for shut off and regulating the cooling circuit within the unit
- V8** Diaphragm valve for condensate sampling

Table of Contents

1	Introduction	Page
	A Brief Overview	4
	The Company	5
	What does Quality mean at SED?	6
	General Information	
	Testing	7
	Qualification, Certification and Documentation	8
	Flow Rate and Valve Sizing	9
	Surface Finish	10, 11
2	Media Contacted Components	
	Diaphragms	14 - 19
	Valve Bodies (fold out page)	20
	Butt Weld Tube Ends (fold out page)	21
	Aseptic Connections	
	Clamps	22
	Aseptic Flanges and Aseptic Threads	23
3	Aseptic Diaphragm Valves	
	Overview Diaphragm Aseptic Valves	26, 27
	Why Aseptic Diaphragm Valve?	28
	Self Draining - Two-Way Valve	29
	Innovative Design	30 - 33
	Aseptic Diaphragm Valves	
	Aseptic Diaphragm Valve Manual	34 - 45
	Aseptic Diaphragm Valve Pneumatically Operated	46 - 61
	Ordering Key and Ordering Example	62, 63
4	Aseptic Diaphragm Valve Configurations	
	D-Rule	66
	Welded Valve Configurations	67 - 69
	Multiport Valves	
	Why Multiport Valves?	70
	Main line open, Loop Valves (e.g. T-Valve)	71 - 75
	All lines and valve ports able to close	76 - 81
	The way of customized multiport valve designs	82
	Specification Multiport Valves	83
	Tank Valves	84 - 87
	Process Solutions	
	Sterile Sampling Unit	88
	Purified Steam Sampling Unit	89
5	Angle Seat Valves	
	Description and Features	92
	Applications	93
	Ordering Key and Ordering Example	94, 95
	Technical Data	96
	2/2-Way Angle Seat Valves	97 - 103
	Valve Body Threaded Socket and Butt Weld End	104
	Valve Body Clamp Socket and Flange	105
6	System Components and Process Automation	
	Overview	108
	Manual Adjustment - Optical Indication	109
	Electrical Switch Boxes - Pilot Control	110
	Detailed Information	
	3/2 Way Plastic Pilot Valve Type 600 / 605	111
	3/2 Way Plastic Pilot Valve Type 602 / 603	112
	Control Head Switch 024.63. - 024.89.	113
	Contact-Free Limit Switch 024.50	114, 115
	Process Automation, Electropneumatic Positioners	116 - 118
	Overview Product Range	119
	Glossary	120, 121

Description and Features



The SED Angle Seat Valve is composed of a 2/2-way angle seat valve body and a pneumatically operated piston actuator, which is mounted with a stainless steel adaption to the valve body. Depending on the size, the actuators are made of plastic or aluminium. The plastic actuators consist of a high temperature resistant plastic. A self-adjusting gland assures reliable longlife performance. The gland is protected against dust and damage by a wiper, which is located in front of the gland.

The SED Angle Seat Valve is suitable for shut off, dosing, control and regulating liquid or gaseous media.

The angle seat valve can be designed to specific requirements.

Applications engineered for optimized flow characteristics is achieved by reduced Kv/Cv-values and equal percentage or linear flow curves.

Even simple solutions like noise reduction are possible.

Features

- High flow rate.
- Assembly of actuator is isolated from the media with sealing prior to the thread.
- 360° adjustable actuator orientation.
- Comprehensive modular accessories suitable for retrofitting after installation.
- Actuator options include normally closed, normally open, or double acting.
- Variety of valve body end connections including threaded socket, butt weld and socket weld in different international standards, flanged ends and sanitary clamps.

Applications

Industries, applications, and media where the SED seat valves may be used.

Industry:

Pharmaceutical, medical, food, beverage, cosmetics, chemical, packaging, plastic, rubber, textile and color industry.

Applications:

Sterilization in CIP and SIP, autoclave, steam generation, washing and cleaning facilities, filling, cooling circuits, heating facilities, boiler construction, dosing, packaging, drying, temperature and pressure control and process flow.

Media:

Steam, water, cooling water, gases, nitrate, compressed air, oils and various chemicals.

Multiport valve for the control and shut off of heating or cooling media, heating of fermentation units and batch boilers.

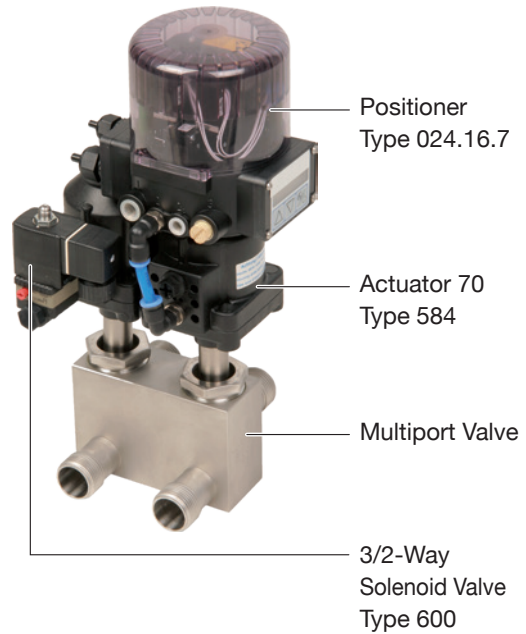

2/2-way angle seat valves with two stage actuator, adjustable stroke limiter, AS-Interface and circumferential optical position indicator, used for the filling of production containers with weighing equipment.

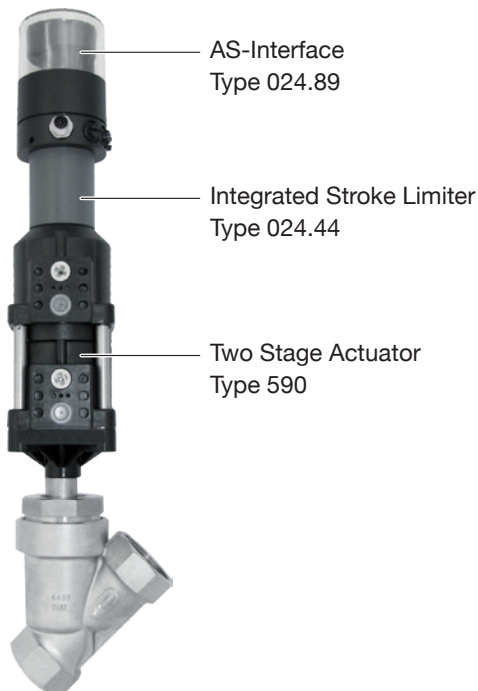

Bioreactor from Solaris biotechnology with SED 2/2-Way Angle Seat Valves for purified steam and diaphragm valves for aseptic media.



Ordering Key and Ordering Example

Pos.	Description	Code	Specification
1	Type:	580	Manual valve, plastic hand wheel
		581	Manual valve, stainless steel hand wheel, metal bellow
		584	Pneumatic valve, plastic actuator material PAMX D6
		585	Pneumatic valve, aluminium actuator
		590	Pneumatic valve, two stage plastic actuator (only Cf. 1)
2	Size:	08-80	DN 8, 10, 15, 20, 25, 32, 40, 50, 65, 80
3	Valve body material:	7	Stainless steel, investment cast 1.4404/S31603, ASME BPE Table MM-2.1-1
		75	Stainless steel, investment cast 1.4408
4	Valve body end connection:	1	Threaded socket BSP
		1N	Threaded socket NPT
		40	Butt weld end ISO 1127 (DIN 11866 Series B)
		41	Butt weld end DIN 11850 Series 1
		42	Butt weld end DIN 11850 Series 2 (DIN 11866 Series A)
		45	Butt weld end ASTM 269 ASME BPE (DIN 11866 Series C)
		49	Butt weld end SMS 3008
		51	Flange PN10/16 DIN 2564, face to face DIN EN 558-1, Series 1
		740	Clamp ISO 1127, for tube EN ISO 1127 face to face DIN EN 558-1, Series 1
		742	Clamp DIN 32676, for tube DIN 11850 face to face DIN EN 558-1, Series 1
745	Clamp ASME BPE, for tube ASME BPE face to face DIN EN 558-1, Series 1		
5	Sealing:	3	Encapsulated circumferential PTFE sealing
6.1	Actuator control function:		Manually operated
		1	Normally closed (NC), orientation 90° to flow direction
		2	Normally open (NO), orientation 90° to flow direction
		3	Double action (DA), orientation in flow direction
6.2	Actuator type:	S	Plastic hand wheel
		T	Stainless steel hand wheel
		43	Plastic actuator with Stainless steel adaption, piston Ø 45 Flow below the seat
		44	Plastic actuator with Stainless steel adaption, piston Ø 45 Flow above the seat
		45	Plastic actuator with Stainless steel adaption, piston Ø 45 Flow below the seat
		46	Plastic actuator with Stainless steel adaption, piston Ø 45 Flow above the seat
		70	Plastic actuator with Stainless steel adaption, piston Ø 70 Flow below the seat
		71	Plastic actuator with Stainless steel adaption, piston Ø 70 Flow above the seat
		125	Aluminium actuator with Stainless steel adaption, piston Ø 125 Flow below the seat
7	Surface roughness of the bodies in Ra: (µm)	02	Internal mechanically polished Ra ≤ 0,8 µm
		03	Internal mechanically polished Ra ≤ 0,8 µm + Electropolished
		07	Internal mechanically polished Ra ≤ 0,6 µm
		08	Internal mechanically polished Ra ≤ 0,6 µm + Electropolished
		09	Internal mechanically polished Ra ≤ 0,4 µm
		10	Internal mechanically polished Ra ≤ 0,4 µm + Electropolished

Bold = preferential standards

Type 584, Actuator 70

Code:	1	2	3	4	5	6.1	6.2
Artikel No.:	584	25	7	1	3	1	45
Type:	584 Pneumatic valve Plastic actuator Material PAMX D6						Actuator Type: Plastic actuator with Stainless steel adaption, piston Ø 45
Size:	DN 25						Actuator Control Function: Normally closed (NC), orientation 90° to flow direction
Valve Body Material:	Stainless steel, investment cast 1.4404/316L			Valve Body End Connection: Threaded socket	Sealing: Encapsulated circumferential PTFE Sealing		

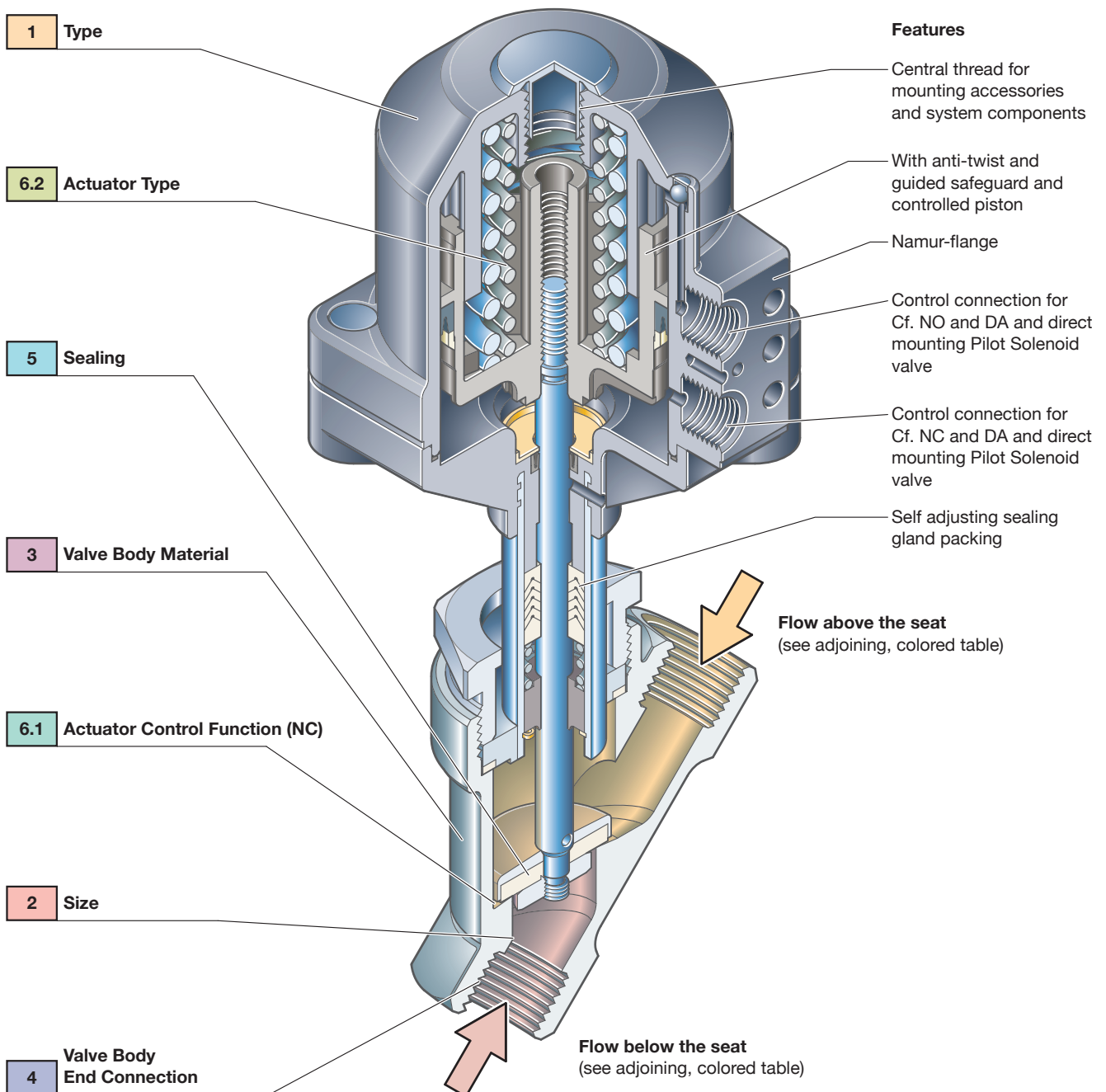

Technical Data

Operating Conditions

Operating Medium:	Neutral, aggressive, gaseous, and liquid media. Media must be compatible with the materials of construction.	Size:	DN 8-80
Viscosity:	Max. 600 mm ² /sec	Valve Body Material:	See ordering key page 94
Medium Temperature:	-10 to +180°C for PTFE sealing	Sealing:	PTFE capsuled (NBR, FKM, EPDM on request)
Working Pressure:	See table	Actuator Material:	See ordering key page 94
Control Medium:	Neutral gases, air	Filling Volume:	Actuator 43, 45, 46 0,03 dm ³ Actuator 70/71 0,13 dm ³ Actuator 120 0,63 dm ³
Temperature			
Control Medium:	Max. +80°C		
Working Temperature:	-10 to +90°C		

Kv-Value Water (m³/h)

Size	8	10-15	15	20	25	32	40	50	65
Kv-Value actuator type code 43	2,1	2,4							
Kv-Value for all actuator types except code 43			5,2	10,0	15,0	22,5	40,0	72,0	105,0

Measuring at 20°C, 1 bar pressure at the valve input and the free outlet, measured at the valve body with threaded socket.

Working Pressure for Valves with flow below the seat

Actuator Type Code	Type	Ø Actuator Piston	Control Function (Cf.)	Control Pressure min. - max. (bar)	Size									
					8-15	15	20	25	32	40	50	65	80	
	580		Manually op.			16	16	16	10	10	10			
	581		Manually op.			10	10	10	10	10	10			
43	584	45	1 (NC)	4,5-7	16									
45	584	45	1 (NC)	4,5-7		11	6	2,5						
70	584/590	70	1 (NC)	4,5-7		25	20	10	7	4,5	3			
125	584	125	1 (NC)	4,5-7			25	25	25	20	15	10	7	
43	584	45	2 (NO)	page 97	25									
45	584	45	2 (NO)	page 98		25	22	14						
70	584	70	2 (NO)	page 99		25	25	25	25	16	11			
125	584	125	2 (NO)	page 100						25	25	22	16	
43	584	45	3 (DA)	page 97	25									
45	584	45	3 (DA)	page 98		25	25	20						
70	584	70	3 (DA)	page 99		25	25	25	25	17	11			
125	584	125	3 (DA)	page 100						25	25	22	16	

Working Pressure for Valves with flow above the seat (suitable to only a limited extent for liquid media, there is a danger of waterhammer)

Actuator Type Code	Type	Ø Actuator Piston	Control Function (Cf.)	Control Pressure min. - max. (bar)	Size									
					8-15	15	20	25	32	40	50	65	80	
46	584	45	1 (NC)	page 98		10	10	10						
71	584	70	1 (NC)	page 99		10	10	10	10	10	10			

All pressures are gauge pressures.

Type 584, Actuator 43

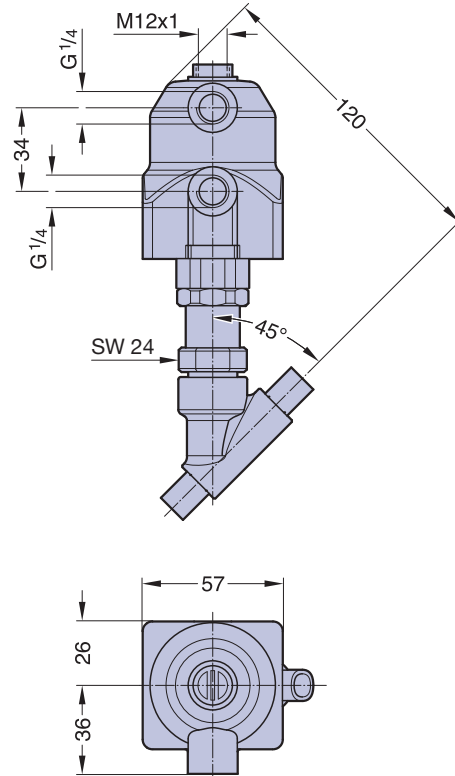

Weight ca. 0,7 kg

Valve body types see page 104 - 105

Control equipment and accessories see page 108 - 115

Actuator 43 (NO), flow below the seat

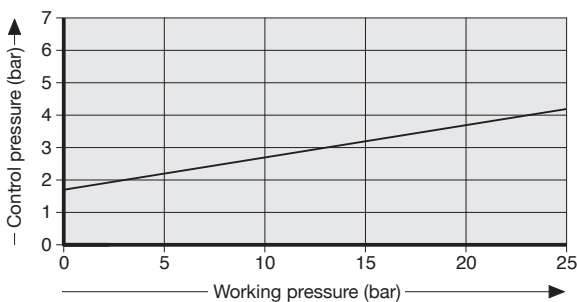

Actuator 43 (DA), flow below the seat

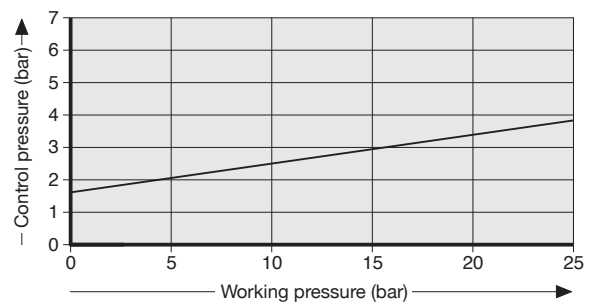

Working pressure normally closed (Cf. 1), flow below the seat as well as Working terms, see table page 96.
All pressures are gauge pressures.

Type 584, Actuator 45 and Actuator 46

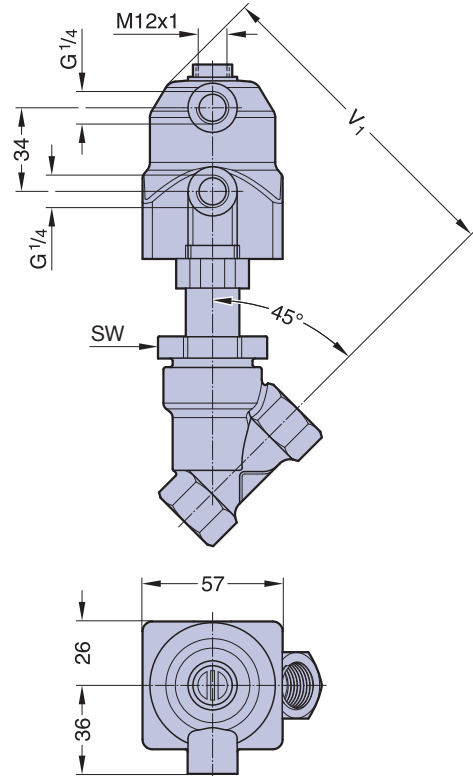

Actuator 45 (NO), flow below the seat

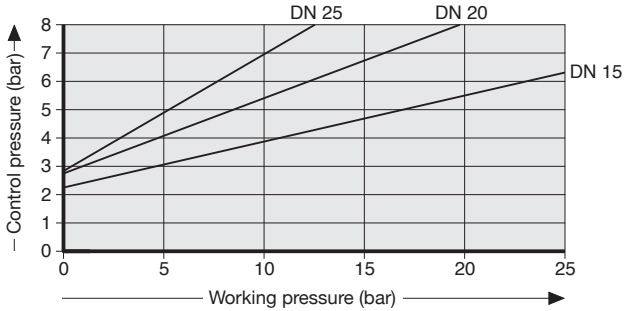

Measurement and weight table Actuator type 45 and 46

DN	SW	V ₁	Total weight ca. (kg)
15	36	130	0,8
20	41	136	1,1
25	46	140	1,2

Valve body types see page 104 - 105

Control equipment and accessories see page 108 - 115

Actuator 45 (DA), flow below the seat

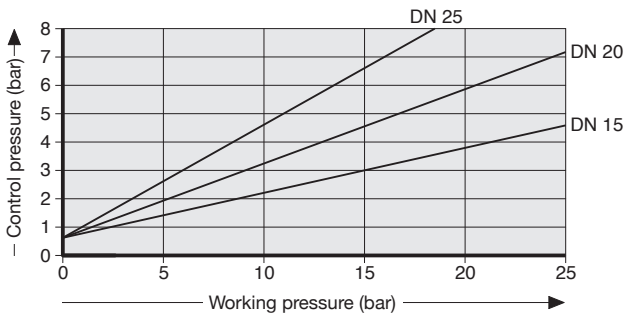

Actuator 46 (NC), flow above the seat

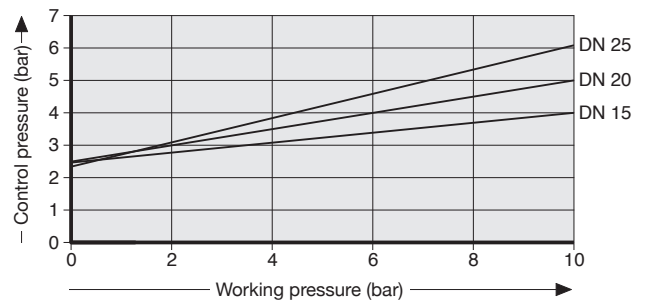

Working pressure normally closed (Cf. 1), flow below the seat as well as Working terms, see table page 96. All pressures are gauge pressures.

Type 584, Actuator 70 and Actuator 71



Namur-Flange
The threaded
bushing
024.583.001 for
the valve mount-
ing necessary
is available on
request.

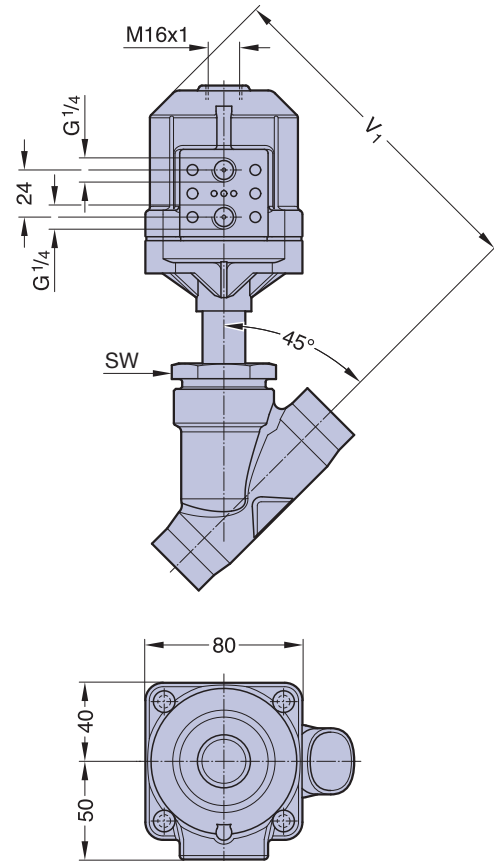

Actuator 70 (NO), flow below the seat

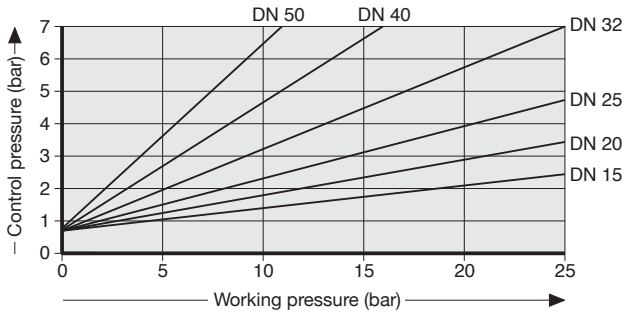

Measurement and weight table Actuator type 70 and 71

DN	SW	V ₁	Total weight ca. (kg)
15	36	162	1,2
20	41	173	1,3
25	46	173	1,6
32	55	179	2,1
40	60	185	2,2
50	75	192	3,2

Valve body types see page 104 - 105

Control equipment and accessories see page 108 - 115

Actuator 70 (DA), flow below the seat

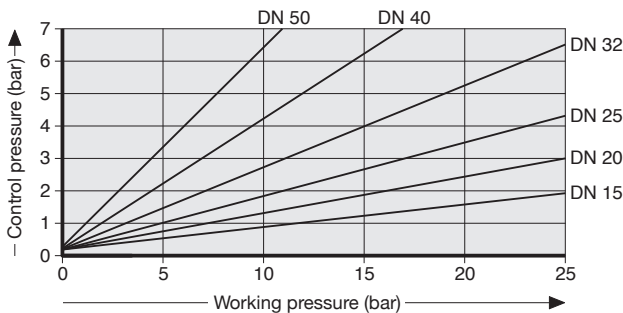

Actuator 71 (NC), flow above the seat

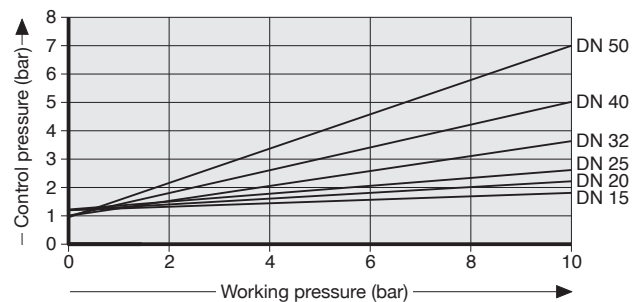

Working pressure normally closed (Cf. 1), flow below the seat as well as Working terms, see table page 96.
All pressures are gauge pressures.

Type 584, Actuator 125

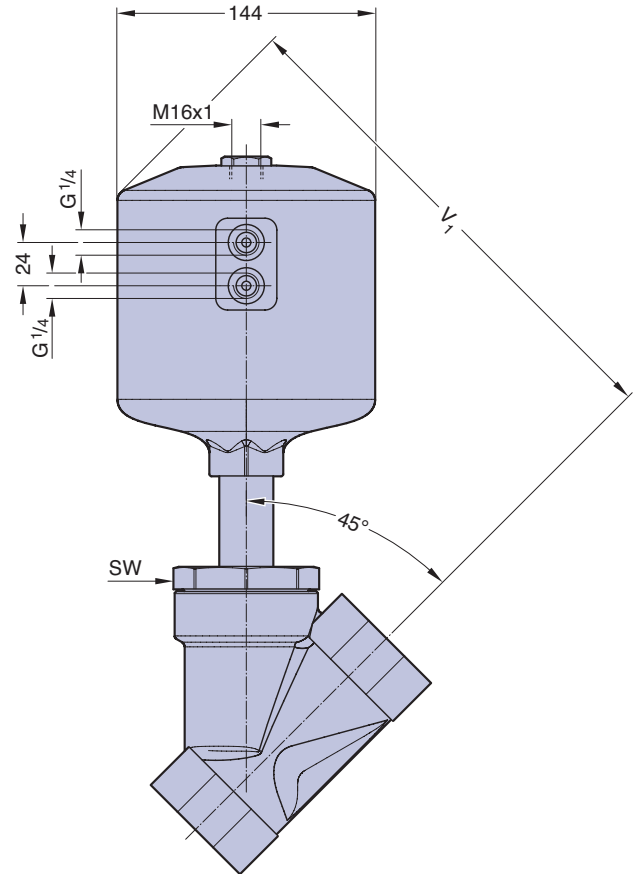

DN	SW	V ₁	Total weight ca. (kg)
20	41	258	3,7
25	46	263	3,9
32	55	269	4,4
40	60	274	4,9
50	75	282	5,9
65	75	295	7,8

Valve body types see page 104 - 105
Control equipment and accessories see page 108 - 115

Actuator 125 (NO), flow below the seat

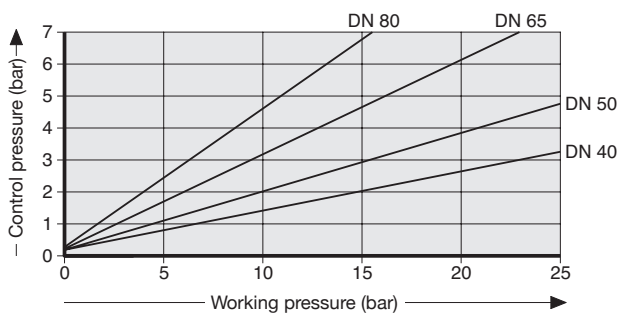

Actuator 125 (DA), flow below the seat

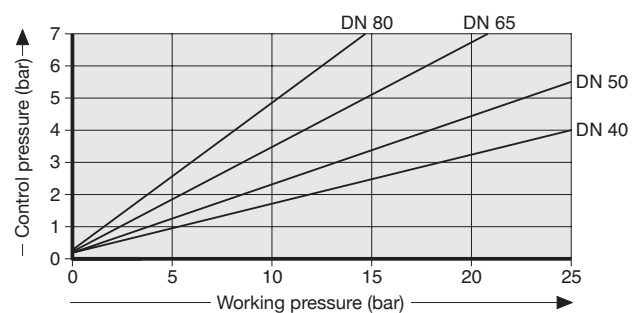

Working pressure normally closed (Cf. 1), flow below the seat as well as Working terms, see table page 96.
All pressures are gauge pressures.

Type 590, Two Stage Actuator 70



Cap
024.17.001
optional

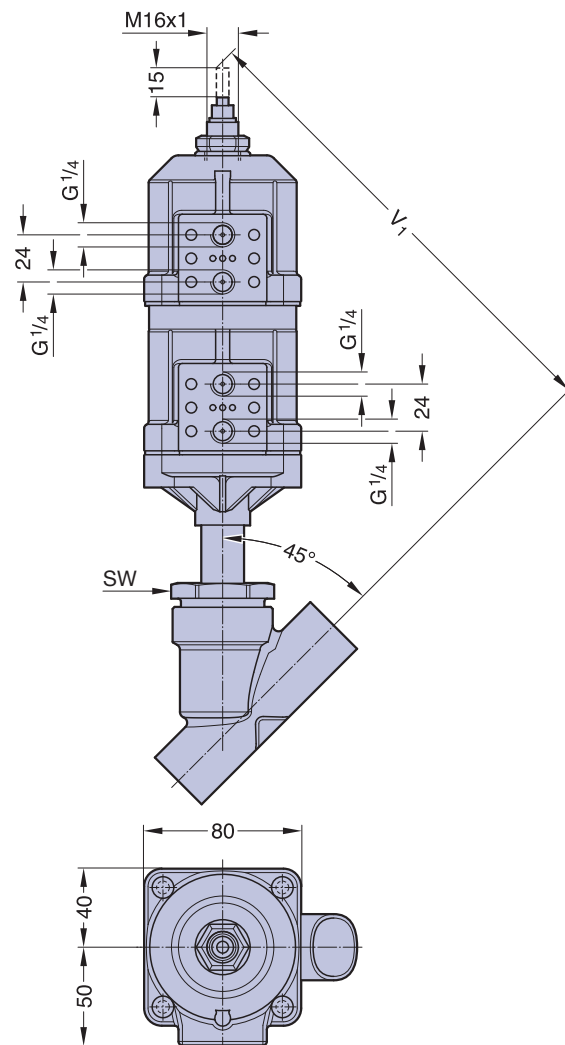

2/2-Way Angle Seat Valves with Two Stage Actuator

The pneumatically controlled two stage piston actuator is made of two plastic actuators. The two stages can be independently actuated from each other.

In order to open the valve completely with the full flowrate, the lower piston has to be actuated. Limited opening or flowrate is possible by actuating the upper piston.

An adjustable stroke limiter allows to adjust the linear movement of the upper position. An optical indicator which is directly connected with the valve spindle shows the stroke.

The control function of the valve is normally closed (Cf.1).

Application

The valve is mainly used for filling with controlled filling of a tank, container or barrel. For filling, the valve is completely opened with the full flow rate. At the end of the filling cycle, the valve automatically reduces to the second stage of filling with a reduced flow rate for an accurate finish fill.

Measurement and weight table Actuator type 70

DN	SW	V ₁	Total weight ca. (kg)
15	36	232	1,9
20	41	238	2,1
25	46	243	2,2
32	55	249	2,9
40	60	255	3
50	75	263	4

Valve body types see page 104 - 105

Control equipment and accessories see page 108 - 115

Working pressure normally closed (Cf. 1), flow below the seat as well as Working terms, see table page 96.
All pressures are gauge pressures.

Type 580, Manually operated

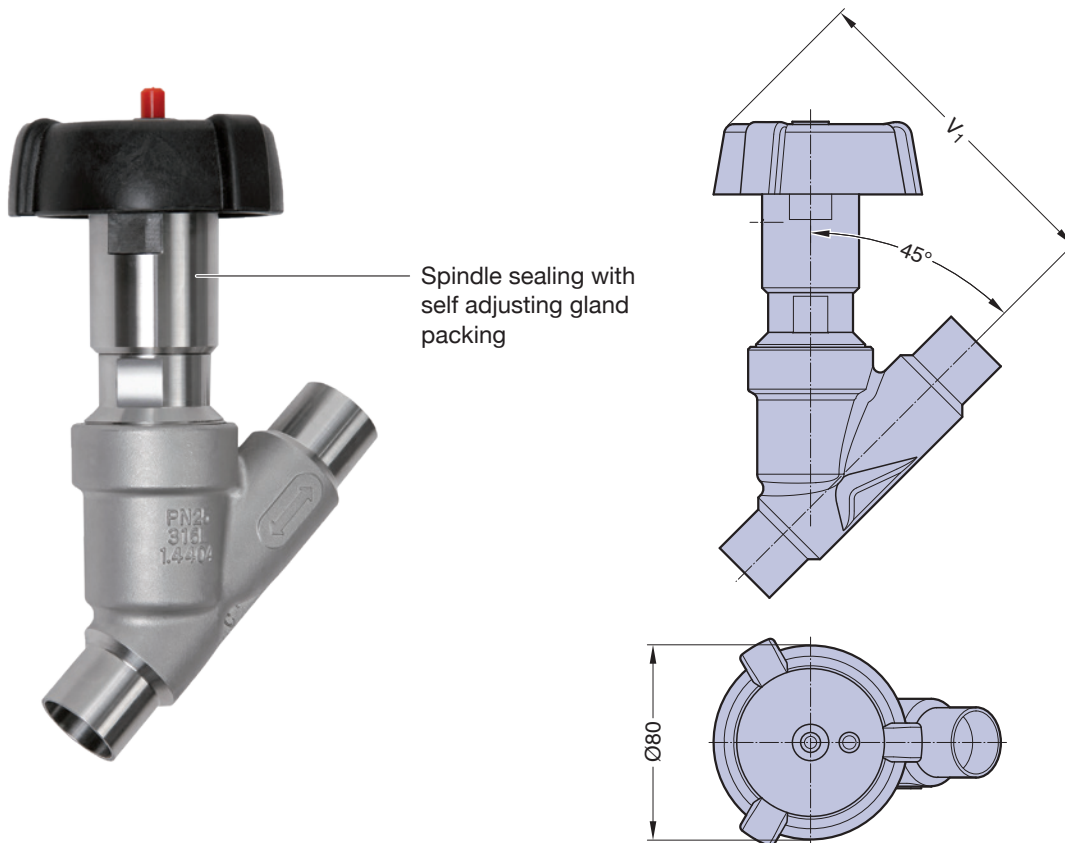

Advantages:

- Hygienic design, easy cleaning
- High temperature resistance
- Minimized dead leg design
- Optical position indicator
- Easy maintenance
- Good regulation properties
- Clean and smooth exterior for sterile washdowns

Measurement and weight table

DN	V_1	Total weight ca. (kg)
15	137	1,1
20	135	1,3
25	135	1,6
32	154	2,3
40	154	2,8
50	154	4,3

Valve body types see page 104 - 105

Control equipment and accessories see page 108 - 115

Working pressure, see table page 96.
All pressures are gauge pressures.

Type 581, Manually operated

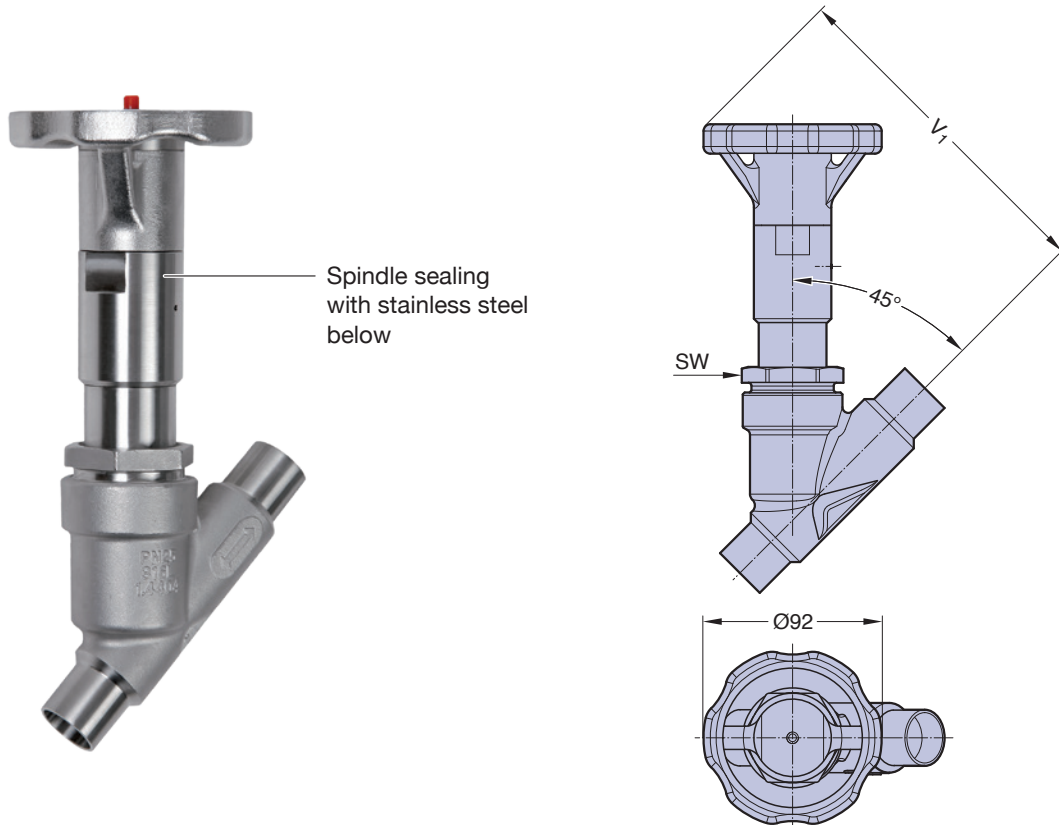

Advantages:

- Hygienic design, easy cleaning
- High temperature resistance
- Stainless steel below
- Minimized dead leg design
- Optical position indicator
- Easy maintenance
- Good regulation properties
- Clean and smooth exterior for sterile washdowns
- Regulating cone

Specific application:

- Pure or clean steam and gaseous media

Measurement and weight table

DN	SW	V ₁	Total weight ca. (kg)
15	36	177	1,8
20	41	168	1,9
25	46	175	2,1
32	55	183	2,9
40	60	189	3,4
50	75	197	4,4

Valve body types see page 104 - 105

Control equipment and accessories see page 108 - 115

Working pressure, see table page 96.
All pressures are gauge pressures.

Valve Body Threaded Socket and Butt Weld End

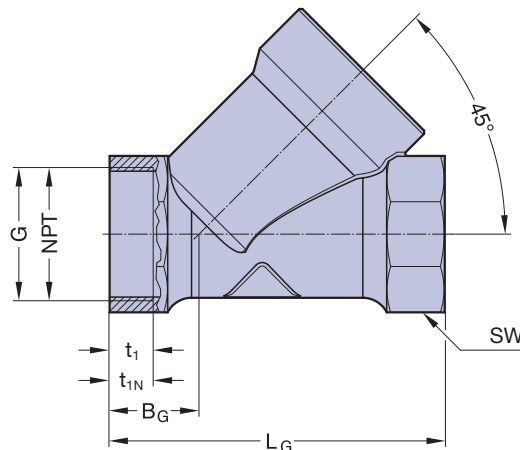

Threaded Socket, Connection Code 1 (DIN ISO 228) & 1N (NPT), Valve Body Material 1.4408 (Code 75)

DN	L _G	B _G	Actuator Type	DIN ISO 228, Code 1		NPT, Code 1N		SW	
				G	t ₁	NPT	t _{1N}		
15	65	17	45, 46, 70, 71	G 1/2	15,0	NPT 1/2	16	27	6-kt
20	75	18	45, 46, 70, 71, 120	G 3/4	14,0	NPT 3/4	17	32	6-kt
25	90	24	45, 46, 70, 71, 120	G 1	15,0	NPT 1	17	39	6-kt
32	110	33	70, 71, 120	G 1 1/4	17,0	n.a.	n.a.	50	8-kt
40	120	30	70, 71, 120	G 1 1/2	17,0	NPT 1 1/2	21	55	8-kt
50	150	40	70, 71, 120	G 2	18,5	NPT 2	22	70	8-kt
65	190	46	120	G 2 1/2	26,0	NPT 2 1/2	30	85	8-kt

Measurements in mm, G-Thread

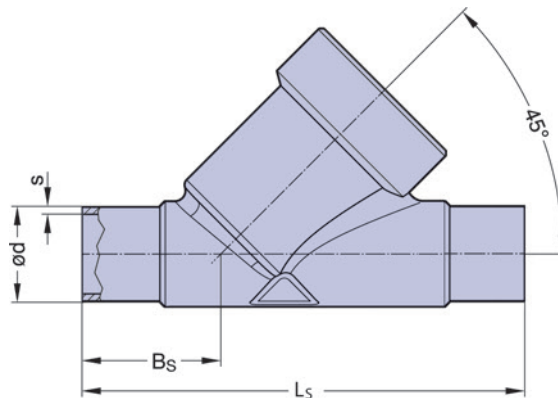

Butt Weld End, Valve Body Material 1.4404/316L (Code 7)

			Connection Code										
			DIN 11850				SMS		ASTM 269		ISO 1127		
			Series 1		Series 2		3008		ASME BPE		40		
Code			41	42	49	45							
DN	LS	BS	Actuator Type	ød	s	ød	s	ød	s	ød	s	ød	s
8	77	26	43, 44	-	-	-	-	-	-	-	-	13,5	1,6
10	77	26	43, 44	12	1	13	1,5	-	-	-	-	-	-
15	77	26	43, 44	-	-	-	-	-	-	12,7	1,65	-	-
15	105	35,5	45, 46, 70, 71	18	1	19	1,5	-	-	-	-	21,3	1,6
20	125	39	45, 46, 70, 71, 120	22	1	23	1,5	-	-	19,05	1,65	26,9	1,6
25	135	38,5	45, 46, 70, 71, 120	28	1	29	1,5	25	1,2	25,4	1,65	33,7	2
32	155	48	70, 71, 120	34	1	35	1,5	-	-	-	-	42,4	2
40	175	47	70, 71, 120	40	1	41	1,5	38	1,2	38,1	1,65	48,3	2
50	205	48	70, 71, 120	52	1	53	1,5	51	1,2	50,8	1,65	60,3	2
65	285	96	120	-	-	70	2	63,5	1,6	63,5	1,65	76,1	2
80	285	96	120	-	-	-	-	76,1	1,6	76,2	1,65	88,9	2,3

Measurements in mm, preferential standards in bold

Valve Body Clamp Socket and Flange

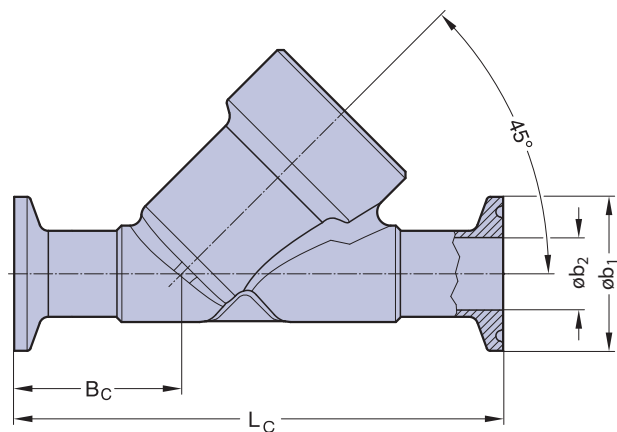

Clamp Socket, Valve Body Material 1.4404/316L (Code 7)

				Connection Code						
Clamp End ident.		Tube End ident.		Similar ISO 2852 ISO 1127	DIN 32676 DIN 11850		ASME BPE ASME BPE			
				740	741 / 742		745			
DN	NPS	LC	BC	Actuator Type	øb1	øb2	øb1	øb2	øb1	øb2
8	1/4	102	39	43, 44	25	10,3	-	-	-	-
10	3/8	102	39	43, 44	-	-	34	10	-	-
15	1/2	102	39	43, 44	-	-	-	-	25	9,4
15	1/2	130	48	45, 46, 70, 71	50,5	18,1	34	16	-	-
20	3/4	150	54	45, 46, 70, 71, 120	50,5	23,7	34	20	25	15,75
25	1	160	56	45, 46, 70, 71, 120	50,5	29,7	50,5	26	50,5	22,1
32	1 1/4	180	60,5	70, 71, 120	64	38,4	50,5	32	-	-
40	1 1/2	200	67	70, 71, 120	64	44,3	50,5	38	50,5	34,8
50	2	230	73	70, 71, 120	77,5	56,3	64	50	64	47,5
65	2 1/2	290	-	120	91	72,1	91	66	77,5	60,2
80	3	310	-	120	130	109,7	-	-	91	72,9

Measurements in mm, NPS inch

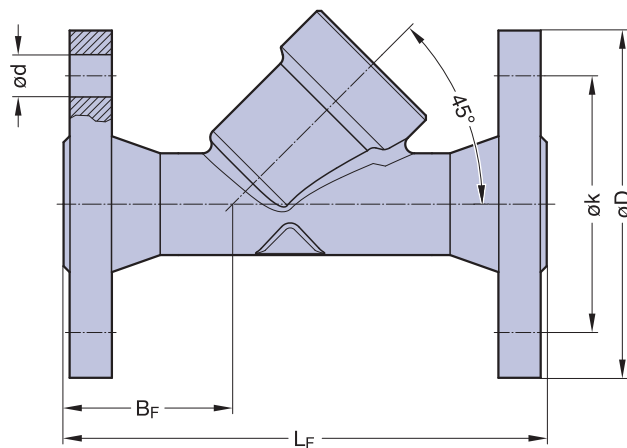

Flange, Connection Code 51, Valve Body Material 1.4408 (Code 75)

DN	LF	BF	Actuator Type	øD	ød	øk	number of drilling
15	130	42	45, 46, 70, 71	95	14	65	4
20	150	54	45, 46, 70, 71, 120	105	14	75	4
25	160	56	45, 46, 70, 71, 120	115	18	85	4
32	180	59	70, 71, 120	140	18	100	4
40	200	71	70, 71, 120	150	18	110	4
50	230	83	70, 71, 120	165	18	125	4
65	290	-	120	185	18	145	4
80	310	-	120	200	18	160	8

Measurements in mm

Table of Contents

1	Introduction	Page
	A Brief Overview	4
	The Company	5
	What does Quality mean at SED?	6
	General Information	
	Testing	7
	Qualification, Certification and Documentation	8
	Flow Rate and Valve Sizing	9
	Surface Finish	10, 11
2	Media Contacted Components	
	Diaphragms	14 - 19
	Valve Bodies (fold out page)	20
	Butt Weld Tube Ends (fold out page)	21
	Aseptic Connections	
	Clamps	22
	Aseptic Flanges and Aseptic Threads	23
3	Aseptic Diaphragm Valves	
	Overview Diaphragm Aseptic Valves	26, 27
	Why Aseptic Diaphragm Valve?	28
	Self Draining - Two-Way Valve	29
	Innovative Design	30 - 33
	Aseptic Diaphragm Valves	
	Aseptic Diaphragm Valve Manual	34 - 45
	Aseptic Diaphragm Valve Pneumatically Operated	46 - 61
	Ordering Key and Ordering Example	62, 63
4	Aseptic Diaphragm Valve Configurations	
	D-Rule	66
	Welded Valve Configurations	67 - 69
	Multiport Valves	
	Why Multiport Valves?	70
	Main line open, Loop Valves (e.g. T-Valve)	71 - 75
	All lines and valve ports able to close	76 - 81
	The way of customized multiport valve designs	82
	Specification Multiport Valves	83
	Tank Valves	84 - 87
	Process Solutions	
	Sterile Sampling Unit	88
	Purified Steam Sampling Unit	89
5	Angle Seat Valves	
	Description and Features	92
	Applications	93
	Ordering Key and Ordering Example	94, 95
	Technical Data	96
	2/2-Way Angle Seat Valves	97 - 103
	Valve Body Threaded Socket and Butt Weld End	104
	Valve Body Clamp Socket and Flange	105
6	System Components and Process Automation	
	Overview	108
	Manual Adjustment - Optical Indication	109
	Electrical Switch Boxes - Pilot Control	110
	Detailed Information	
	3/2 Way Plastic Pilot Valve Type 600 / 605	111
	3/2 Way Plastic Pilot Valve Type 602 / 603	112
	Control Head Switch 024.63. - 024.89.	113
	Contact-Free Limit Switch 024.50	114, 115
	Process Automation, Electropneumatic Positioners	116 - 118
	Overview Product Range	119
	Glossary	120, 121

System Components and Process Automation

Overview

Description	Type	Diaphragm size (MA)	Suitable for valve			Detail see page
			Range	Pneumatically operated	Manual	
Optical position indicator	024.10	8 - 100	DN 4 - 100	●	●	109
Stroke limiter	024.11	8 - 100	DN 4 - 100	●	●	109
Stroke Limiter with hand wheel	024.12.2	8	DN 8 - 15	●		109
Stroke limiter with optical position indicator	024.12	8 - 100	DN 4 - 100	●	●	109
Manual override with optical position indicator	024.13	8 - 50	DN 4 - 50	●		109
Handwheel to open normally closed valves (NC) or close normally open valves (NO)	024.42	25 - 100	DN 15 - 100	●		109
Contact - Free Limit Switch	024.50	8 - 100	DN 4 - 100	●		110, 114 - 115
Control head switch with optical indicator "catch the eye"	024.63 024.64 024.65	8 - 100	DN 4 - 100	●		110, 113
Control head switch with "catch the eye" optical indicator AS - Interface	024.89	8 - 100	DN 4 - 100	●		110, 113
Limit switch with one mechanical switch and optical indicator	024.90	8 - 100	DN 4 - 100	●	●	110
Pilot valve for direct mounting	600	8 - 100	200 NL	●		111
Pilot valve for direct mounting	602	8 - 100	60 NL	●		112
Pilot valve for manifold mounting	603	8 - 100	60 NL	●		112
Pilot valve for manifold mounting	605	8 - 100	200 NL	●		111
Manual valve prepared for mounting proximity switch	024.96	25 - 100	DN 15 - 100		●	
Adapter for direct mounting one proximity direct on top in the valve actuator	SO795	8 - 100	DN 4 - 100	●		
Travel stop	024.886	8 - 100	DN 4 - 100	●	●	

System Components and Accessories are shown on page 109 - 115.

System Components and Process Automation

Manual Adjustment - Optical Indication



024.11
Stroke Limiter
optional with cap



024.12.2
Stroke Limiter
with hand wheel



024.12
Stroke Limiter
with Optical Position
Indicator
optional with cap



024.13
Manual Override
with Optical
Position Indicator



024.10
Optical Position Indicator



024.42
Handwheel to open normally
closed valves (NC) or close
normally open valves (NO)



Upon request combinations of Manual Adjustments with Switch Boxes are available

System Components and Process Automation

Electrical Switch Boxes - Pilot Control

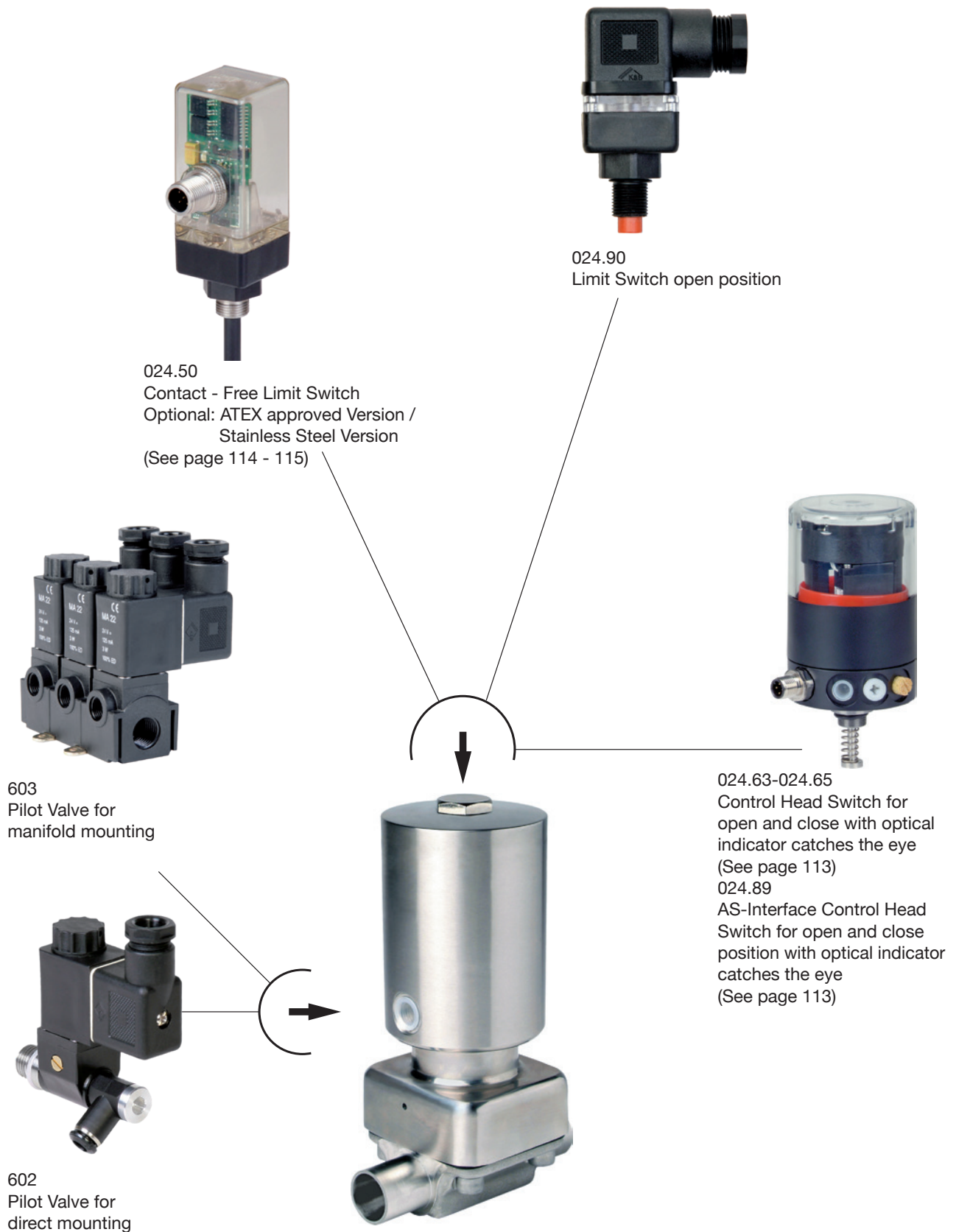

Upon request combinations of Manual Adjustments with Switch Boxes are available

System Components and Process Automation

3/2 Way Plastic Pilot Valve Type 600 / 605

Description

Direct solenoid actuated poppet valve, normally closed and normally open, direct and manifold mounting. Solenoid valve for filtered, lubricated or non lubricated air, neutral gaseous and liquid fluids.

Features

- Compact design
- Interchangeable solenoid system
- Plastic overmolded solenoid
- suited for coarse vacuum
- Exhaust port provided with silencer
- Standard manual override
- Current draw 5 W

Type 600

Connections: Threaded socket 1/8" BSP. Inlet and Outlet arranged at an angle of 90°. Suitable for direct mounting on process valve, by hollow screw with 1/4" or 1/8" BSP thread.

Type 605

Connections: threaded inlet G 1/4" outlet G 1/8". Inlet and outlet arranged at an angle of 90°. Suitable for manifold mounting. May also be used as a single valve.



Technical Data

Nominal size	1,6 mm
Line connection	G 1/8"
Operating pressure	0 - 10 bar
Flow rate	Qn 200 l/min
Voltages	
AC	24V40-60 Hz, 110V40-60 Hz, 220V40-60 Hz
DC	12V, 24V, 48V, 100V, 110V, 200V

Switching time appr.	On 14 ms
	Out 9 ms
Current draw	5W (6VA)
Protection Class ICE/EN 60529	IP 65
Temperature range	-10 to +60°C
AC	210 g
DC	PBT

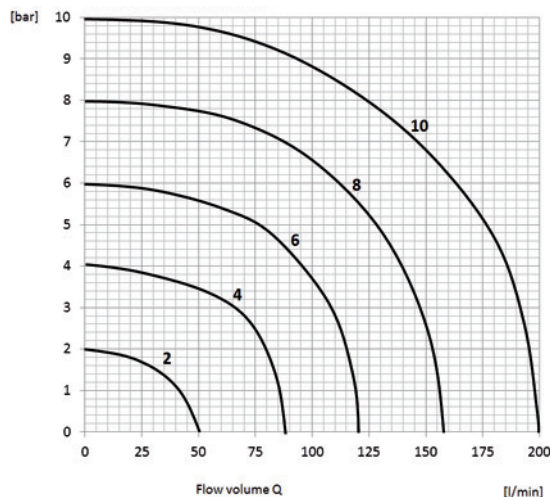

The diagram illustrates the flow rate for gases in normal litres per minute. For examples: inlet pressure 6 bar and pressure drop (Δp) 2 bar. mark the point of intersection of the 6 bar curve and the horizontal line for 2 bar Δp . Move vertically from this point to the bottom scale and read off the flow rate in NL per minute.

System Components and Process Automation

3/2 Way Plastic Pilot Valve Type 602 / 603

Description

The solenoid valves are electromagnetic, direct actuated pilot valves to control pneumatically operated valve actuators. Applicable media are filtered, lubricated or non lubricated air and neutral gaseous fluids.

Type 602 is equipped with a hollow screw and made for direct mounting on the user.

Type 603 is designed for manifold mounting, where a variable amount of single pilot valves are assembled together and connected to the pneumatically operated valve actuators by pneumatic lines.

Features

- Compact design
- Identical position of all ports for version normally open and normally closed (except connection M5)
- Plastic wrapped electromagnet
- Interchangeable solenoid system
- 360° adjustable position of electromagnet
- Also suitable for coarse vacuum
- Silenced exhaust port
- Manual override (depending on version)
- Any installation position possible
- Cable plug can be mounted turned by 180°
- Combined exhaust optional
- Optional
 - ATEX-Version for explosion-risk areas
 - UL-approval
- Mounting rail for manifold mounting
Type 603 available as option



Type 602
Banjo with push-in connection
for tube Ø 6mm



Type 602
Banjo with threaded socket G1/8"



Type 603
Manifold assembly

Standard versions

Type	Cf.	Version	Connection			Manual- override	Fig.
			P1	P2	P3		
602.1,2.32.24.2.1.S5.1.xx*	1	Direct mounting, Banjo	Push-in connection f. tube Ø 6mm	G1/8" or G1/4" Plunger		Yes	1
602.1,2.32.24.2.1.35.1.xx*	1	Direct mounting, Banjo	Threaded socket G1/8"	G1/8" or G1/4" Plunger		Yes	1
602.1,2.32.24.2.2.S5.1.xx*	2	Direct mounting, Banjo	Push-in connection f. tube Ø 6mm	G1/8" or G1/4" Plunger		No	1
602.1,2.32.24.2.2.35.1.xx*	2	Direct mounting, Banjo	Threaded socket G1/8"	G1/8" or G1/4" Plunger		No	1
602.1,2.32.24.2.2.M5.1.xx*	2	Direct mounting, Banjo	Thread M5 at plunger	G1/8" or G1/4" G1/8"		Yes	2
603.1,2.32.24.2.1.43.1.xx*	1	Manifold mounting	Threaded socket G1/4"	G1/8"	Plunger	Yes	3
603.1,2.32.24.2.2.43.1.xx*	2	Manifold mounting	Threaded socket G1/4"	G1/8"	Plunger	No	3

For detailed information please see TD130020

Control Head Switch 024.63. - 024.89.

The SED electrical control head is an innovative development based on years of experience in manufacturing electrical accessories for process valves.

Depending on the version, the electrical control head provides signals for both open and closed positions of the valve and includes an integral solenoid valve for a direct air line connection to the actuator.

Ease of Assembly:

Because of the design, the electrical control head is suitable for assembly with all linear valves. The threaded adapter of the electrical control head is designed to screw into the top of the valve actuator. A spring pushes the stem of the electrical control head onto the valve actuator stem. The spring allows for the electrical control head stem to follow freely the linear movement of the valve actuator stem. This electrical control head may be mounted on the valve actuator in the field without disassembly of any components.

Self Positioning:

After mounting the electrical control head, the two cams activating the switches in the electrical control head will be mechanically moved by overcoming their holding force on the spindle. To adjust the closed position, the electrical control head stem will be pushed down until contact is made with the valve actuator stem.

The adjustment of the open position takes place at the first stroke of the valve. The circumferential optical indicator is suspended on the cam for the closed position and represents the entire stroke of the valve.

For the electrical connection a pre-wired pin or Bus-connection is available. The electrical control head has a reliable output and service life and contributes considerably to cost savings when considering assembly, application, and self adjustment as compared to other conventional control head options available.

Features:

- Increased air flow rate 230 NI/min
- Circumferential catch the eye optical indicator representing the full stroke
- Ease of assembly and may be assembled with the valve actuator in the field
- Time saving electrical interface via pre-wired pin or a Bus-connection
- Compact design
- Position feedback versions with:
 - Electromechanical switch
 - Inductive initiators Namur or PNP
 - AS-Interface
- Suitable for mounting on linear valves
- Depending on the specification, LED indication is available

Optional:

- Integral solenoid valve with direct air line connection to actuator
- Stroke limiter for the valve stroke adjustment

For more details see TD15 0094



Position valve open:

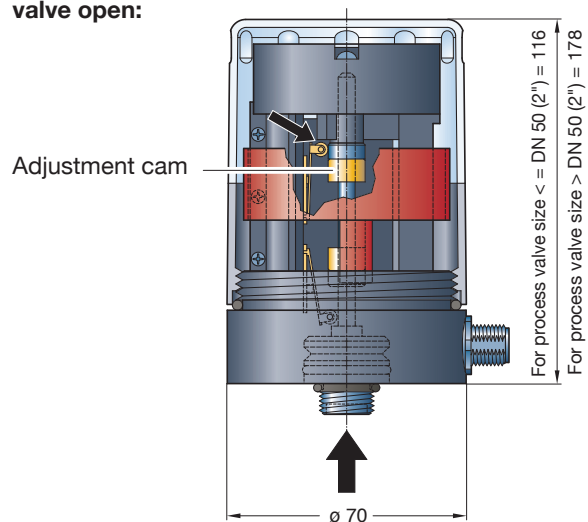

Position valve closed:

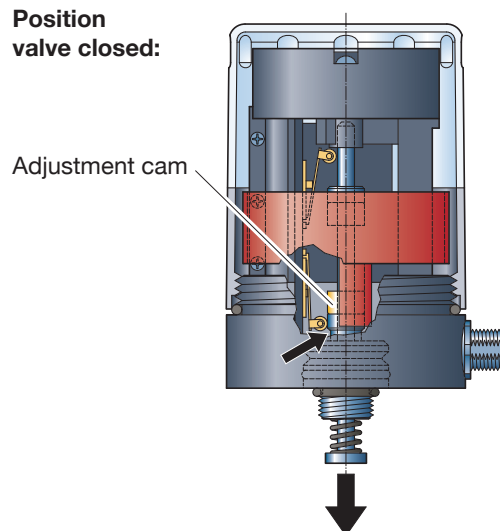

Versions Control Head

Code	Electrical Connection	Electro-mechanical limit switch Open/Close (pcs)	Proximity switch		Solenoid Valves ¹ (pcs)
			Namur (2-wire) (pcs)	PNP (3-wire) (pcs)	
024.63.	Pre-wired 8 pins M12 x 1	2			
024.64.	Pre-wired 8 pins M12 x 1		2		
024.65.	Pre-wired 8 pins M12 x 1			2	
024.89.6 AS-Interface	Pre-wired 4 pins M12 x 1	2			1
024.89.7 AS-Interface	Pre-wired 4 pins M12 x 1			2	1

The ASI version offers the integral solenoid valve as standard.

¹ On request, two 3/2 way solenoid valves can be integrated for all versions.

Contact - Free Limit Switch 024.50

Limit switches are used to control, monitor and view the position of the valve or to activate other system components.

There are different versions of on/off limit switches in the market. The most common are based on the principle of mechanical switches, proximity sensors or potentiometers.

SED has designed and engineered a contact-free limit switch with magnet field measurement technology. Apart from lifetime and among other features the advanced design allows also a more reliable sealing method.



Standard Version

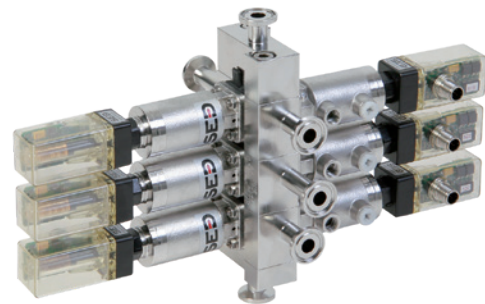

Application example

Features

- For single and double acting valve control functions
- Suitable for linear and rotary actuators
- Power supply and programming 24V DC or 8V DC
- Linear stroke measurement of 3-45 mm
- Indicates two or three positions
- Backlash free stroke transmission
- Short circuit proof
- M12, 5 pin A-coded connection

Optional:

- Atex II 2G
 - II 2D
 - II 3G
- IO-Link (in preparation)

Advantages

- Contact-Free magnetic measuring design
- Colored LED light feedback of valve position visible for 360°
- Compact and robust design
- Hermetically sealed
- Easy mounting without additional adapter kits
- Mounts to all standard valves up to DN100
- 360° adjustable mounting position
- Initial programming by light or 24V Signal (5th pin)
- Set point protection
- High switching current
- High chemical resistance

System Components and Process Automation

Contact - Free Limit Switch 024.50

Technical Data





Material Housing	PPSU
Mechanical Adaption	St. Steel M12x1, M16x1
Ambient Temperature	-10°C to + 70°C
Maximum Pressure	8 bar
Power Supply	Standard and II 3G = 24V optional 8V ATEX II 2D/G = 10V
Power Consumption	0,7 W
Maximum Power Input	30 mA / 40mA ¹
Electrical Connection	Multipol M12, 5 Pin, A-coded
Switching Current	1 ... 800 mA / 1mA ¹ / 10V ¹
Stroke-/ Slewing- Range	3 - 45 mm / 360°
Accuracy	+/- 0,1 mm
Protection Class	IP67 according EN 60529
Conformity according CE	EMV-9/336/EWG
Mounting Position	any
Initialization	Light or 24V / 10V ¹ Signal

¹ ATEX II 2D/G

Ordering Key

Assembly Thread	Code	
	for Linear Actuator	for Rotary Actuator
M12x1	024.50.120	n.a.
M16x1	024.50.160	024.50.260

Optical Position Feedback

Position	LED Indication	
open	permanent green	
interim, if any	permanent yellow	
closed	permanent blue	
moving open	blinking green	
moving closed	blinking blue	

Dimensional Drawing

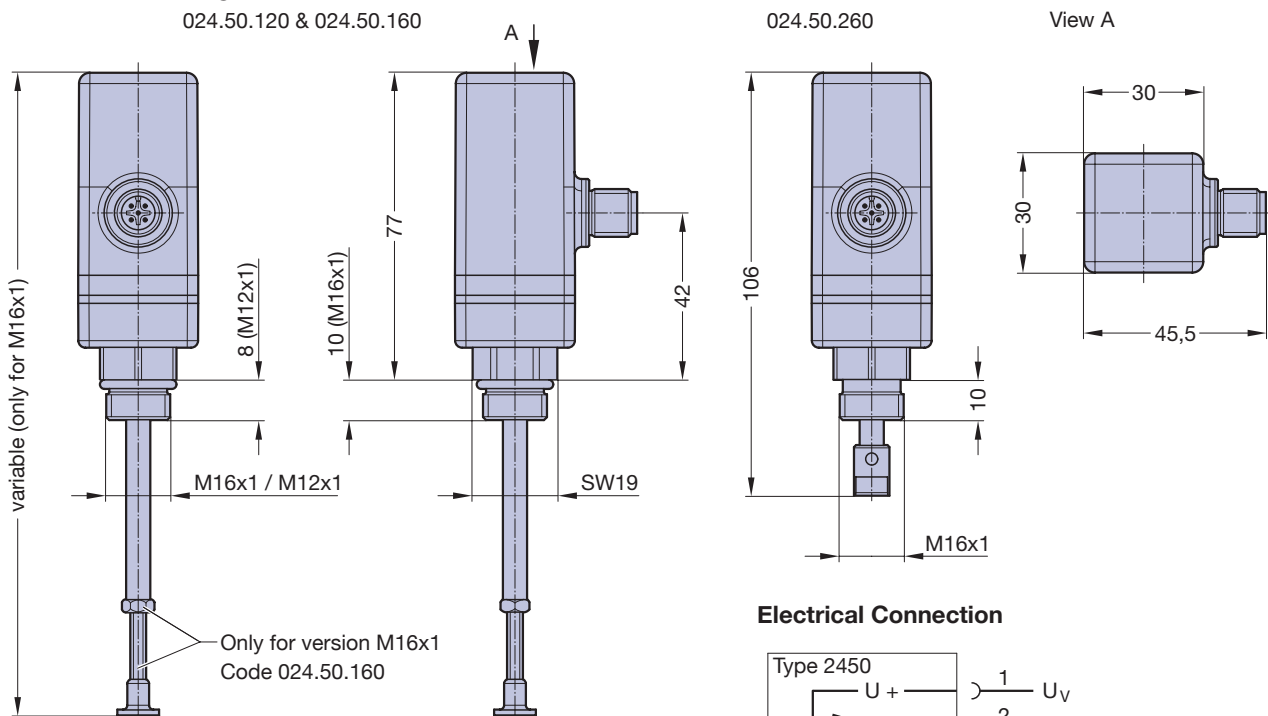

Accessories

- 2 m cable with 4 pin female plug for explosion-risk areas, Code 00311.2450.006.4
- 5 m cable with 5 pin female plug, Code 00311.2450.006.1
- 15 m cable with 5 pin female plug, Code 00311.2450.006.6

Optional

Teach-In cable for the programming via the 5th pin, Code 00311.2450.005

Electrical Connection

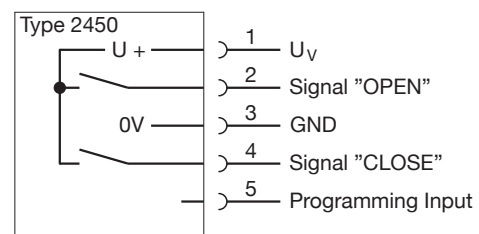

Pin Configuration

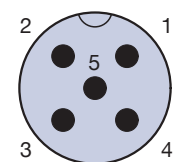

5 pin, M12, A-coded

System Components and Process Automation

Electropneumatic Positioners ECOCENT 024.16.7

for central mounting on the top of the process control valves

Main Features:

- Compact stainless steel, high performance plastic design
- Contact-free continuous sensor measuring of the valve spindle position
- Easy start up
- Pneumatic positioning for single acting actuators
- High air flow rate for type 024.16.720
- Close tight function

Type 024.16.720



Valve assembled with Positioner 024.16.710



Type	024.16.720	024.16.710
Recommended for valve size	DN 50 - 100	DN 8 - 50

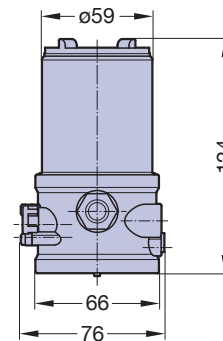
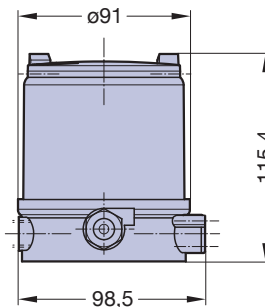

Body; Cocer; Sealing	PPS/stainless steel; PC transparent; EPDM	PPS/stainless steel; PC transparent; EPDM
Ambient temperature	0 - 55°C	0 - 55°C
Control medium	Neutral gases, air according DIN ISO 8573-1	Neutral gases, air according DIN ISO 8573-1
Pilot air ports	G 1/8	G 1/8
Supply pressure; Air flow rate	3 - 7 bar 1; 130 NI/min	1 - 7 bar 1; 7 NI/min
Intrinsic air consumption	0 l/min	0 l/min
Power supply	24 V DC +/- 10%	24 V DC +/- 10%
Power consumption	< 3,5 W	< 3,5 W
Electrical connection	Multipol M12 (8- pins), stainless steel	Multipol M12 (8- pins), stainless steel
Setpoint setting; Output resistance	4 to 20 mA; 180 Ohm	4 to 20 mA; 180 Ohm
Analogue feedback 4 - 20 mA	Standard	Optional
Stroke range valve spindle	3 - 45 mm	3...28 mm
Binary input	0 - 5 V = log "0", 10 - 30 V = log "1"	0 - 5 V = log "0", 10 - 30 V = log "1"
AS-Interface	optional	NO
Operation	2 Key button	2 Key button
Visualisation	2 LEDs	2 LEDs
Protection class	IP65/67 according to EN 60529 (only if cables plugs and sockets have been connected properly and in compliance with the exhaust air concept in chapter "pneumatic connection of positioner")	
Conformity	subject to CE according EMV2004/108/EG	subject to CE according EMV2004/108/EG
Approval	CSA on request.	CSA on request.
Process controller	Optional	NO

¹ Pressure stated in bar: are access to atmosphere; the supply pressure has to be 0,5 - 1 bar above the minimum required pilot pressure for the valve actuator

System Components and Process Automation

Electropneumatic Positioner ECOSIDE 024.16.420

for process valves big stroke range and with remote control installation

Main Features:

- Compact metal housing
- Contact-free continuous sensor measuring of the valve spindle position
- Simple start up using tune function
- Pneumatic positioning for single and double-acting actuators
- High air capacity
- Standardized for assembly according IEC 534-6 / VDI VDE 3845
- Available as remote version with position sensor
- Close tight function
- ATEX-Version available

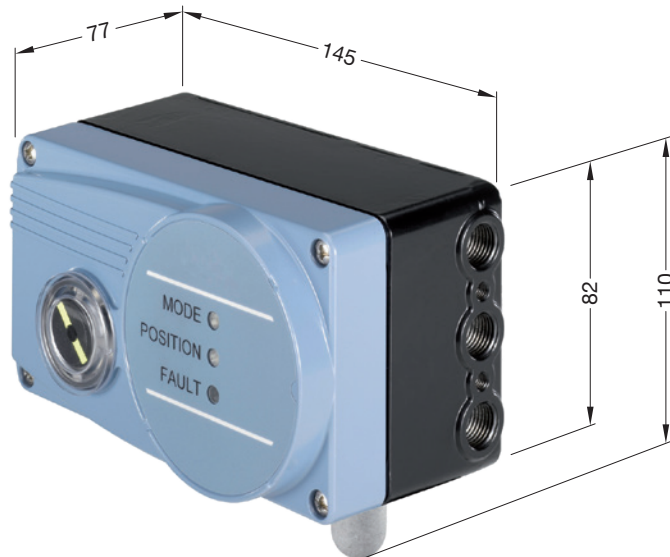
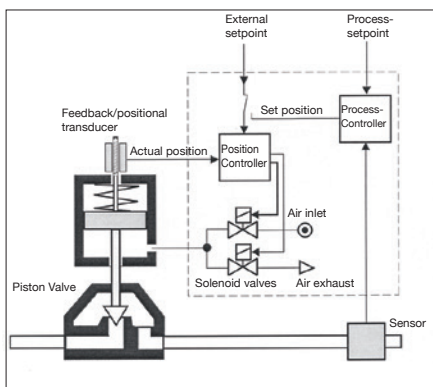

Type	024.16.420
Recommended for valve size	DN25 - 200
Body; Sealing	Aluminum plastic coated; EPDM
Ambient temperature	0 - 60°C
Control medium	Neutral gases, air according DIN ISO 8573-1
Pilot air ports	G 1/4
Supply pressure	1,4 - 7 bar ¹⁾
Air flow rate	Single and double-acting up to 150 NI/min ($Q_{Nn} = 100$ NI/min acc. Definition with decrease in pressure from 7 to 6 bar absolute)
Intrinsic air consumption	0 l/min
Power supply	24 V DC +/- 10%
Power consumption	< 3,5 W
Electrical connection	M12 (8 Pins)
Cable gland	2 x M20 x 1,5 (cable Ø 10 mm) on screw terminal
Remote version	1 x M12 x 1,5 (cable Ø3 to 6,5 mm)
Setting point; input resistance	5 to 20 mA / 180 Ohm (0 - 20 mA adjustable with configuration software)
Binary Input	0 - 5 V = log "0", 10 - 30 V = log "1"
Stroke range valve spindle	Min. 30° on the rotary shaft, depending on lever
Operation	2 Key button
Visualisation	2 LEDs
Protection class	IP65/67 acc. EN 60529
Type of ignition protection	II 3 G nA II B T4 II 3 D tD A22 T135°
Conformity	EMV2004/108/EG
Approval	CSA
Optional	Process controller Analogue feedback 4 - 20 mA AS-Interface

1) Pressure stated in bar: are access to atmosphere;

the supply pressure has to be 0,5 - 1 bar above the minimum required pilot pressure for the valve actuator

System Components and Process Automation

Electropneumatic Positioners ECOSIDE 024.16.402

for process valves big stroke range and with remote control installation

Main Features:

- Compact and robust metal housing
- Simple start up using tube function
- Pneumatic positioning for single and double-acting actuators
- High air capacity
- Close tight function
- ATEX approval II 2 (1) G Ex ia IIC T6 Gb

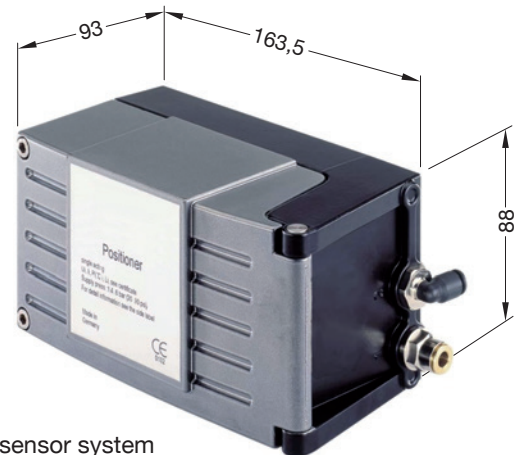

Assembly exclusively with position sensor system

Type	024.16.402
Body; Sealing	Aluminium, hard anodized and plastic coated
Ambient temperature	-25 ... +60 °C ¹⁾
Control medium	neutral gases, air according DIN ISO 8573-1
Pilot air ports	G 1/4
Supply pressure	1.4 - 6 bar ³⁾
Air flow rate	55 l/min at 1.4 bar ³⁾ 170 l/min at 6 bar ³⁾ for pressurizing and venting
Intrinsic air consumption	0 l/min
Power supply	via setpoint input 4-20mA
Burden voltage	< 12 VDC
Burden resistance	590 Ω at 20mA and 11.8 VDC
Electrical connection	2 x M20 x 1.5-bushing Clamping range 6 ... 12 mm Screw terminals for 0.14 ... 1.5 mm ²⁾
Remote version	available (only with the approved sensor)
Setting point; input resistance	4 ... 20 mA; 590 Ω
Binary Input	mechanical NC/ NO contact
Positioning range	Linear actuator: 3... 130 mm Part-turn actuator: 0... 120 °
Operation	3 operating keys
Visualisation	Plain-text display (internal)
Protection class	IP65 acc. to EN 60529
Type of ignition protection	II 2 (1) G Ex ia IIC T6 Gb acc. to EN 60079-0:2012 and EN 60079-11:2012
Conformity	EMC 2004/108/EC
Approvals	ATEX EEx ia II C T6
Certification	PTB 04 ATEX 2027 / IECEx PTB 04.0016
Optional	Analogue feedback 4 - 20 mA Process value input (4... 20mA) Use in the Ex area (Zone 1)
Assembly	Assembly set required

1) Up to +65 °C temperature class T4/T5 or without EEx i approval.

2) May be adapted to actuator size with throttle screw.

3) Pressure data in bar; overpressure to ambient.

Overview Product Range

Diaphragm Valve



Aseptic Diaphragm Valve



Industrial Metal Diaphragm Valve



Plastic Diaphragm Valve

Angle Seat Valve



Two-Way Metal Angle Seat Valve

Aseptic Process Solution



Sterile sampling unit

System Components



Contact - Free Limit Switch



Control Head



Digital Electropneumatic Positioner

Flow Measurement



Variable Area Flowmeter



Measuring Sensor

Glossary

Term	Acronym	Definition
3A Sanitary Standards and Accepted Practices	3A	Determines criteria for the cleanability of dairy processing equipment. They have been adopted by many other liquid processing industries outside of dairy.
Active Pharmaceutical Ingredients	API	A substance used in a finished pharmaceutical product (FPP), intended to furnish pharmacological activity or to otherwise have direct effect in the diagnosis, cure, mitigation, treatment or prevention of disease, or to have direct effect in restoring, correcting or modifying physiological functions in human beings.
American Society of Mechanical Engineers	ASME	Creates consensus standards for Mechanical Engineering
American Society for the Testing of Materials	ASTM	Creates consensus standards for material quality and material quality testing methods.
Approved for Construction	AFC	An Approved for Construction (AFC) means that drawings and documents are reviewed and approved by authorities of internal and external organisations including the client team members for the construction. A Construction team must use only AFC marked or stamped drawings and documents for the construction works and activities.
BioProcessing Equipment Committee	BPE	A sub-committee of ASME. It creates engineering standards for the design, specification, manufacture and documentation of equipment used for biopharm processes.
Clean in Place	CIP	The technique of cleaning process line components without the need for relocation or disassembly.
Comite Européen de Normalisation	CEN	Committee for European Standardization Creates standards that reflect the best practices in each industry and is supported by DIN and ISO.
Current Good Manufacturing Practices	cGMP	Current design and operating practices developed by the pharmaceutical industry to meet FDA requirements as published in the Code of Federal Regulations. They reflect the least common denominator of practices in the industry at present.
Deionized Water	DIW	Process of the extraction of deionized water through ion exchange resins.
Deutsches Institut für Normung	DIN	German Institute for Standardization Creates engineering standards for Germany and is contributing body to CEN and ISO.
Design Qualification	DQ	Design Qualification is used at the stage where a design that has been developed from the, VMP / URS /GAMP 5 / cGMP / and other Health and Safety Guidelines, is reviewed and documented by competent persons to ensure that the designed equipment, if built, will satisfy all the detailed specified requirements.
Electro-Polish	EP or E/P	Electrochemical polishing process for metal components where metal ions are removed from the surface of the metal.
European Hygienic Equipment Design Group	EHEDG	The group's objective is to provide standardization organizations (CEN and ISO) with specialist views on hygienic and aseptic design by publishing requirements and test methods. Accredited bodies carry out cleaning tests which are certified if successful.
European Pharmacopoeia	EP	European counterpart to USP. A private, non-profit organization that sets standards for drugs, drug ingredients, medical devices and diagnostics.
Engineering, Procurement, and Construction	EPC	Engineering, Procurement, and Construction" is a particular form of contracting arrangement used in some industries where the EPC Contractor is made responsible for all the activities from design, procurement, construction, to commissioning and handover of the project to the End-User or Owner.
Factory Acceptance Test	FAT	Is usually preformed at the vendor prior to shipping to a client. The vendor tests the system in accordance with the clients approved test plans and specifications to show that system is at a point to be installed and tested on site.
Food and Drug Administration (USA)	FDA	Enforcement agency of the U.S. Government for food, drug and cosmetics manufacturing. Author of the U.S. cGMP's. Responsible for new product approvals, plant inspections and product recalls.

Glossary

Term	Acronym	Definition
International Standards Organization	ISO	Creates consensus standards for engineering and quality systems.
International Society for Pharmaceutical Engineering	ISPE	The world's largest not-for-profit association serving its Members by leading scientific, technical and regulatory advancement throughout the entire pharmaceutical lifecycle.
Installation Qualification	IQ	The Installation Qualification Protocol verifies the proper installation and configuration of a System.
Mill Test Report or Material Test Report	MTR	A document certifying the composition of a metal from a particular heat batch.
Operational Qualification	OQ	The Operational Qualification Protocol is a collection of test cases used to verify the proper functioning of a system.
Performance Qualification	PQ	Performance Qualifications are a collection of test cases used to verify that a system performs as expected under simulated real-world conditions.
Piping and Instrumentation Diagram	P&ID	American standard for process diagrams Diagrams on which the process, the instruments and the flow scheme are defined
Point of Use	POU	A valve outlet in a recirculation utility system (typically a water system).
Purified Water	PW	Ingredient water (not for injection) or rinse water for pharmaceutical products conforming to USP guidelines. Obtained by distillation, reverse osmosis, ion exchange or any other suitable process.
Site Acceptance Test	SAT	A SAT is a Site Acceptance Test the system is tested in accordance to client approved test plans and specifications to show the system is installed properly and interfaces with other systems and peripherals in its working environment.
Steam in Place	SIP	Sanitization of process line components by the use of steam without the need for relocation or disassembly.
Total Oxidizable Carbon or Total Organic Carbon	TOC	A measure of the amount of organic compounds in a water sample. Carbon is oxidized and the level of CO ₂ is measured. The proposed USP water standards are based on TOC analysis.
United States Pharmacopoeia	USP	A private, non-profit organization that sets standards for drugs, drug ingredients, medical devices, and diagnostics. The FDA enforces the established standards.
User Requirement Specification	URS	The User Requirements Specification describes the business needs for what users require from the system. User Requirements Specifications are written early in the validation process, typically before the system is created.
Water for Injection	WFI	Water for use as a solvent for the preparation of parenteral products conforming to USP guidelines. Obtained most commonly by distillation.

Notes

Website



<http://www.sed-flowcontrol.com/en/>

Product Configurator



<http://www.sed-flowcontrol.com/en/configurator/>

- Easy **configuration of products** live on the screen
- Automatic creation of **CAD- files** in various file formats
- Send request and download product descriptions

Manual diaphragm valve type 905



<http://www.sed-flowcontrol.com/en/service/movies>

Contact - Free Limit switch 024.50



<http://www.sed-flowcontrol.com/en/service/movies>

SAMSON

SAMSON SED

CATALOG

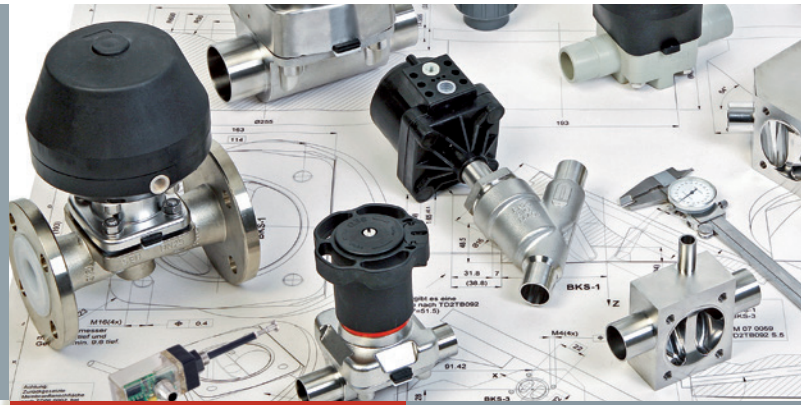

Valves
for aseptic
Applications

SED Flow Control GmbH
Am Schafbaum 2 · 74906 Bad Rappenau, Germany
Phone: +49 7264 921 0 · Fax: +49 7264 921 21
E-mail: info@sed-flowcontrol.com · Internet: www.sed-flowcontrol.com



TD06 0018 Rev.1, Subject to alteration

SMART IN FLOW CONTROL.